

SHORT WAVE CRAFT

Edited by
HUGO GERNSBACK

LISTEN TO THE
WHOLE WORLD
ON RADIO SHORT WAVES

NEW RADIO
SHORT WAVE
SUPERHETERODYNE

SHORT WAVES FOR THE
BROADCAST LISTENER

ULTRA SHORT WAVES

SHORT WAVES IN MEDICINE

OVER 100 HOOK-UPS

NEW EXPERIMENTS



ARTICLES BY

F. H. Schnell
Dr. E. Schliephake
Dr. Albert Neuburger
"Bob" Hertzberg
Dr. Fritz Noack
Eric H. Palmer
R. W. Tanner, W8AD
H. W. Secor
J. E. Smith
A. Binneweg Jr.

50¢

5,000

Radio Service Men Needed Now!

The replacing of the old battery operated receivers with all-electric Radios has created a tremendous country-wide demand for expert Radio Service Men. Thousands of trained men are needed quick!



30 Days of R.T.A. Home Training

... enables you to cash in on this latest opportunity in Radio

\$40 to \$100
a week
Full Time
\$3.00 *an hour*
Spare Time

Ever on the alert for new ways of helping our members make more money out of Radio, the Radio Training Association of America now offers ambitious men an intensified training course in Radio Service Work. By taking this training you can qualify for Radio Service Work in 30 days, earn \$3.00 an hour and up, spare time; prepare yourself for full-time work paying \$40 to \$100 a week.

hour spare time or \$40 to \$100 a week full time, this R. T. A. training offers you the opportunity of a lifetime.

Radio Service Work a Quick Route to the Big-Pay Radio Positions

Radio Service Work gives you the basic experience you need to qualify for the big \$8,000, \$10,000 to \$25,000 a year Radio positions. Once you get this experience, the whole range of rich opportunities in Radio lies open before you. Training in the Association, starting as a Radio Service Man, is one of the quickest, most profitable ways of qualifying for rapid advancement.

We furnish you with all the equipment you need to become a Radio Service Man!

More Positions Open Than There Are Trained Men to Fill Them

If you were qualified for Radio Service Work today, we could place you. We can't begin to fill the requests that pour in from great Radio organizations and dealers. Members wanting full-time positions are being placed as soon as they qualify. 5,000 more men are needed *quick!* If you want to get into Radio, earn \$3.00 an

investigate this R. T. A. training and the rich money-making opportunities it opens up. No special education or electrical experience necessary. The will to succeed is all you need.

Mail Coupon for No-Cost Training Offer

Cash in on Radio's latest opportunity! Enroll in the Association. For a limited time we will give to the ambitious man a No-Cost Membership which need not . . . should not . . . cost you a cent. But you must act quickly. Filling out coupon can enable you to cash in on Radio within 30 days, lift you out of the small-pay, no-opportunity rut, into a field where phenomenal earnings await the ambitious. You owe it to yourself to investigate. Fill out coupon NOW for details of No-Cost Membership.

The Radio Training Association of America
4513 Ravenswood Ave. Dept. SWC-6, Chicago, Ill.

THE RADIO TRAINING ASSOCIATION OF AMERICA
4513 Ravenswood Ave., Dept. SWC-6, Chicago, Ill.

Gentlemen: Please send me details of your No-Cost training offer by which I can qualify for Radio Service Work within 30 days. This does not obligate me in any way.

Name.....

Address.....

City..... State.....

I will train you at home



Here's Proof

to fill a **BIG PAY** Radio Job!



I will give you my new 8 OUTFITS of RADIO PARTS for a home Experimental Laboratory

If you are earning a penny less than \$50 a week, send for my book of information on the opportunities in Radio. It is free. Clip the coupon NOW. Why be satisfied with \$25, \$30 or \$40 a week for longer than the short time it takes to get ready for Radio.

Radio's growth opening hundreds of \$50, \$75, \$100 a week jobs every year

In about ten years Radio has grown from a \$2,000,000 to a \$1,000,000,000 industry. Over 300,000 jobs have been created. Hundreds more are being opened every year by its continued growth. Men and young men with the right training—the kind of training I give you—are needed continually.

You have many jobs to choose from

Broadcasting stations use engineers, operators, station managers and pay \$1,800 to \$5,000 a year. Manufacturers continually need testers, inspectors, foremen, engineers, service men, buyers, for jobs paying up to \$15,000 a year. Shipping companies use hundreds of Radio operators, give them world wide travel at practically no expense and a salary of \$85 to \$200 a month. Dealers and jobbers employ service men, salesmen, buyers, managers, and pay \$30 to \$100 a week. There are many other opportunities too. My book tells you about them.

So many opportunities many N. R. I. men make \$5 to \$25 a week while learning

The day you enroll with me I'll show you how to do 10 jobs, common in most every neighborhood, for spare time money. Throughout your course I send you information on servicing popular makes of sets; I give you the plans and ideas that are making \$200 to \$1,000 for hundreds of N. R. I. students in their spare time while studying.

Talking Movies, Television, Wired Radio Included

Radio principles as used in Talking Movies, Television and home Television experiments, Wired Radio, Radio's use in Aviation, are all given. I am so sure that I can train you satisfactorily that I will agree in writing to refund every penny of your tuition if you are not satisfied with my Lessons and Instruction Service upon completing.

64-page book of information FREE

Get your copy today. It tells you where Radio's good jobs are, what they pay, tells you about my course, what others who have taken it are doing and making. Find out what Radio offers you, without the slightest obligation. ACT NOW.

**J. E. SMITH, President
National Radio Institute Dept., OH-90
Washington, D. C.**

Our Own Home
Pioneer and World's Largest Home-Study Radio training organization devoted entirely to training men and young men for good jobs in the Radio industry. Our growth has paralleled Radio's growth. We occupy three hundred times as much floor space now as we did when organized in 1914.



\$500 extra in 6 months

"In looking over my records I find I made \$500 from January to May in my spare time. My best week brought me \$107. I have only one regret regarding your course—I should have taken it long ago."

**HOYT MOORE
R. R. 3, Box 919,
Indianapolis, Ind.,**

Lifetime Employment Service to all Graduates

You can build over 100 circuits with these outfits. You build and experiment with the circuits used in Crosley, Atwater - Kent, Eveready, Majestic, Zenith, and other popular sets. You learn how these sets work, why they work, how to make them work. This makes learning at home easy, fascinating, practical.



Back view of 5 tube Screen Grid A. C. tuned Radio frequency set—only one of many circuits you can build with my outfits.

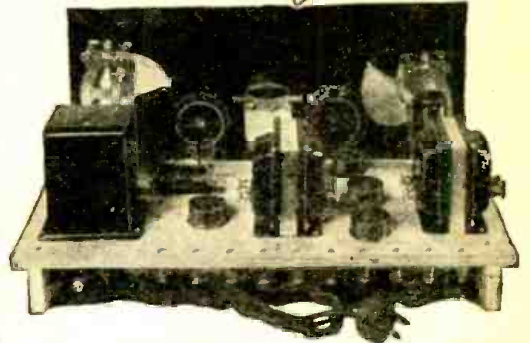

I am doubling and tripling the salaries of many in one year and less Find out about this quick way to

BIGGER PAY



FILL OUT AND MAIL THIS COUPON TODAY

J. E. SMITH, President,
National Radio Institute, Dept. OH-90
Washington, D. C.

Dear Mr. Smith: Send me your book. This request does not obligate me.

Name
Address
City State

HUGO GERNSBACK, Editor

H. WINFIELD SECOR, Managing Editor

CONTENTS

AUGUST-SEPTEMBER

In This Issue: Prominent Short Wave Authors

Schnell – Hertzberg – Palmer – Neuburger – Schliephake – Binneweg

FEATURE ARTICLES:

The Television Theatre Is Here!.....	102
My Short Wave Experiments in Carlsbad Cavern, by Eric H. Palmer, Jr.....	106
Artificial Fever and Other Effects in the Human Body Produced by Short Waves.....	108
Television on Short Waves, by D. E. Replogle....	111
"My Favorite" Short Wave Receiver, by F. H. Schnell, Famous Short Wave Specialist.....	114
Aerials Used in Byrd Broadcast, by H. Winfield Secor	118
Cathode Ray Records High Frequency Oscillations	121
Use of Aircraft Radiophone Spreads.....	122
The Mercury Super-Ten Short Wave Receiver... Short Wave Converters—How to Build Them, by Henry B. Herman.....	126
A Short Wave "Fun Box", by Clyde Fitch.....	130
Transoceanic Short Waves, by Dr. Fritz Noack...	134
The Short Wave Aerial, by C. H. W. Nason.....	142
Ultra Short Waves in Medicine, by Dr. E. Schliephake	148
Short Wave Operation Hints, by Robert "Bob" Hertzberg	154

SHORT WAVES FOR THE BROADCAST LISTENER:

Short Wave Converters—How to Build Them....	130
A Short Wave "Fun Box"—Receiver and Broad- cast Set Adapter.....	132
The "Sun" Short Wave Tuner and Adapter, by Jack Grand	137

SHORT WAVE RECEIVERS:

"My Favorite" Short Wave Receiver, by F. H. Schnell	114
Mercury Super-Ten Short Wave Receiver—A Super-heterodyne Using Peanut Tubes.....	126
The "S-W Four" Short Wave Receiver.....	129
A Short Wave "Fun Box".....	132
The "Sun" Short Wave Tuner.....	137
The Leutz Short Wave Receiver de Luxe.....	140
The "S-M Bearcat" Receiver for Short Waves...	145
The Grebe Short Wave Receiver.....	146
How to Build a Super-Het Short Wave Receiver, by R. William Tanner (W8AD).....	150
The HY-7 Super-Het Short Wave Receiver.....	158

SHORT WAVE TRANSMITTERS:

A 75 Watt Short Wave Transmitter of Superior Quality	125
A Simple 5 Meter Transmitter and Receiver, by E. T. Somerset (G2DT).....	139
The Short Wave Aerial and R. F. Transmission Line, by C. H. W. Nason.....	142
Ultra Short Wave Transmitters and Receivers, by Dr. Ernest Busse.....	147
What Is the Wave Length of Your Body? by A. Binneweg.....	153

AIRCRAFT AND TELEVISION SHORT WAVE SETS:

The Television Theatre Is Here!.....	102
Television on Short Waves by D. E. Replogle....	110
Use of Aircraft Radiophone Spreads—Western Electric Co.'s Airplane Sets With Hook-ups..	122

REGULAR MONTHLY DEPARTMENTS

Short Waves for the Broadcast Listener.....	130
The Short Wave Experimenter.....	136
Short Wave Stations of the World—Directory....	144
Ultra-Short Waves	147
Short Wave Question Box.....	157
SWAPPERS	174

MISCELLANEOUS:

Plant Growth Speeded Up by Ultra Short Waves, by Dr. Albert Neuburger.....	117
Cathode Ray Records High Frequency Oscillations	121
The Problem of Building a Good Short Wave Re- ceiver, by J. E. Smith.....	135
Three Useful Short Wave Wrinkles, by A. J. Green	136
G5SW Broadcasting on 11.55 Meters.....	141
Radio Etiquette	143
Ultra Short Waves in Medicine, by Dr. E. Schliephake	148
To Think Fast, Heat Your Brain With Short Waves!	149
Home Practice Radio Code Outfit.....	156

SHORT WAVE CRAFT—Bi-monthly. Application for second class entry at the post office at Mount Morris, Ill., under the act of March 3, 1879, pending. Copyright, 1930, by Popular Book Corporation. Text and illustrations of this magazine are copyrighted and must not be reproduced without permission.

SHORT WAVE CRAFT is published on the 15th of every other month. Six numbers per year. Subscription price is \$3.00 a year in the United States and possessions. Canada and foreign countries, \$3.50 a year.

Single copies 50c. Address all contributions for publication to Editor, SHORT WAVE CRAFT, 96-98 Park Place, New York, N. Y. Publishers are not responsible for lost manuscripts. Contributions cannot be returned unless authors remit full postage.

SHORT WAVE CRAFT is for sale at all principal newsstands in the United States and Canada. European agents: Brentano's, London and Paris. Printed in U. S. A. Make all subscription checks payable to Popular Book Corporation.

Published by **POPULAR BOOK CORPORATION**

H. GERNSBACK, President - H. W. SECOR, Vice-President

Publication Office, 404 N. Wesley Avenue, Mount Morris, Ill.
Editorial and General Offices, 96-98 Park Place, New York, N. Y.

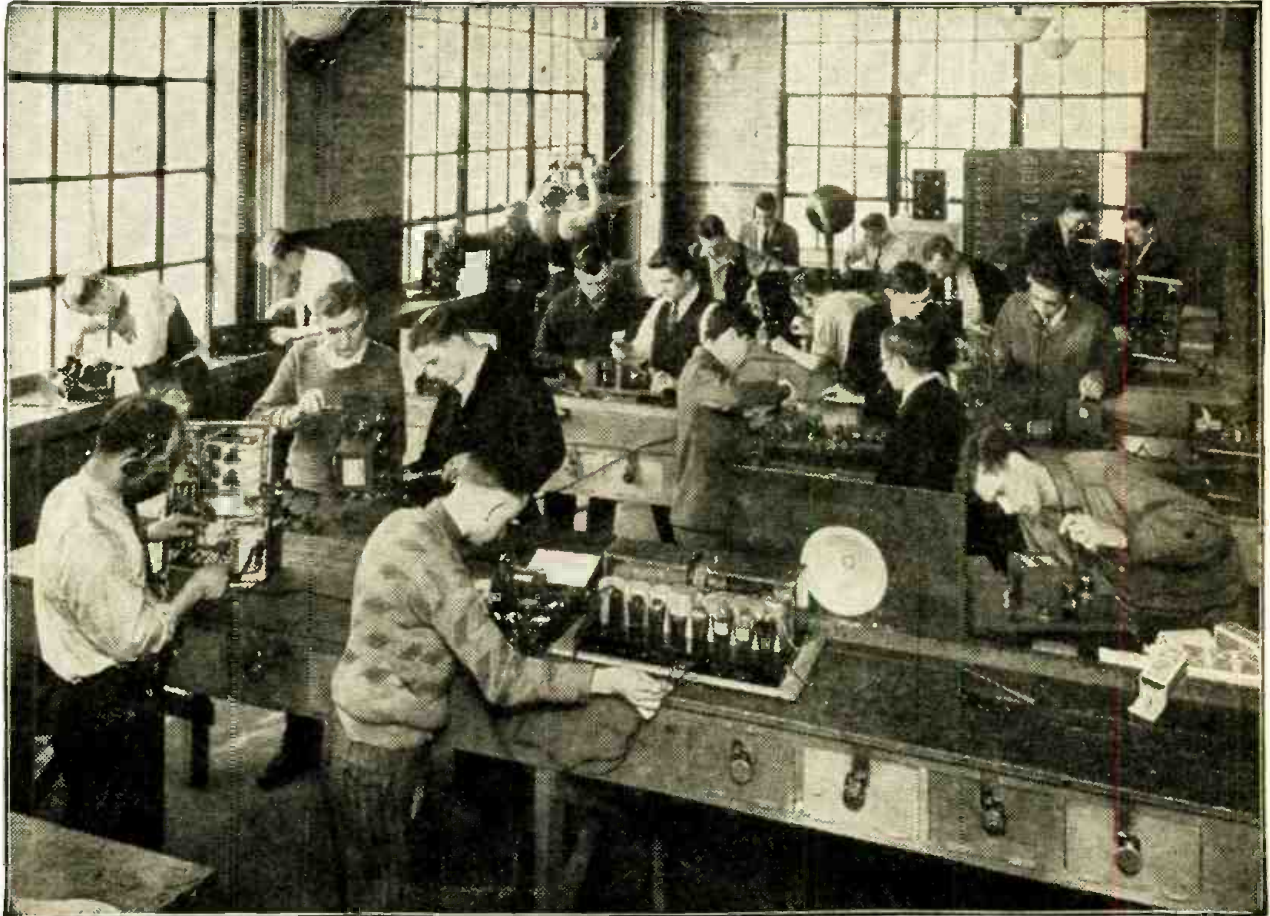

YOU Radio Men!

STATISTICS in the radio industry show that at the present time the ordinary radio man, either as a repair man or Service Man, makes an average of \$35.00 a week. Let us show you how you can quickly qualify for jobs leading to salaries of \$60.00, \$70.00, or \$100.00 a week and up—NOT by books or correspondence, but by an entirely new way.

We Teach You How—No Books—No Lessons—No Classes!

Coyne is not a correspondence school. We actually show you, by expert instructors, every phase of radio; which it is impossible to learn from books or from correspondence courses.

The majority of Radio Service Men and Radio Experts today do not earn what they should, because they have never been properly grounded in the fundamentals of radio—that is to say, in electricity.

Remember, you will never qualify as an expert radio man unless you know the fundamentals of electricity. All of this is taught by ACTUAL WORK on real equipment in our school.

From \$20.00 a Week to \$100.00 a Week

"Before going to Coyne, I had worked in a garage for five years at \$20.00 a week. I had no advanced education and didn't know a volt from an ampere. Yet I graduated in three months with a grade of 98%. Since I left Coyne, I have jumped from \$20.00 to \$100.00 a week, and am still going strong. I owe all my success to the practical training I got in the Coyne Shops."—Harry A. Ward, Iowa.

COYNE ELECTRICAL SCHOOL, H. C. Lewis, Pres. 500 S. Paulina St. Founded 1899 Dept. 60-78, Chicago, Ill.

Most self-taught radio Service Men fail utterly because their electrical education has been neglected; and, incidentally, they lose a good income because statistics show that radio alone cannot support the independent radio man all year around.

In the Spring and Summer time, particularly, radio is notoriously dull; and the radio man who is an electrical expert will make more money in the end.

Radio Training

The photograph above shows how men are actually trained in our big radio shop, where students are shown by experts how to take apart and put together the various modern radio sets. We will show you how to get at the root of servicing troubles; and within 90 days you can be a radio expert.

Most radio men today flounder around because they do not know the peculiarities of many sets, and have to puzzle these out, tediously, for themselves; whereas our instructors, with years of experience behind them, can show you how to locate any set troubles.

No Previous Training Necessary!

Remember, I do not teach you out of books. You are actually doing the work yourself, and get all the experience you need right here at Coyne.

I do not care whether you cannot tell a vacuum tube from a C-battery; whether you are sixteen years old or forty-five. It is my job to prepare YOU for a big-pay radio and electrical job in 90 days' time.

The Future of Radio

At the present time, there is a dire need for REAL and experienced Service Men, who

also know the ins-and-outs of electricity. Even though you may work on a good salary job for an employer at first, sooner or later you will wish to establish yourself in your community and start in business for yourself. The combination of radio and electricity cannot be beat; it is an all-year-round business.

Even if you do not want to go in business, there are more jobs today than good men to fill them. Coyne training settles the job question for life. Only recently one concern called on me for 150 graduates, and calls for more men are coming in daily. Coyne maintains an expert Employment Department, which will help you and back you as long as you live, WITHOUT ONE CENT OF COST TO YOU.

Special Offer!

In connection with the radio training, you are also given electrical training in all its branches—auto ignition and aviation electricity—WITHOUT ONE CENT EXTRA COST!

Get My Free Book

Mail the coupon today, and let me send you the big Coyne book of 150 photographs—facts—jobs—salaries. It costs nothing, and does not obligate you in any way. Just mail the coupon.

MAIL THIS COUPON—NOW!

Mr. H. C. LEWIS, President
COYNE ELECTRICAL SCHOOL, Dept. 60-78
500 S. Paulina St., Chicago, Ill.

Dear Mr. Lewis:

Without obligation send me your big free catalog and all details of Railroad Fare to Chicago, Free Employment Service, Radio, Aviation Electricity, and Auto-motive Courses, and how I can "earn while learning."

Name

Address

City..... State.....

**WORLD-WIDE
RECEPTION**

WITH THE NEW

NORDEN-HAUCK

SHORT-WAVE

SUPER DX-5

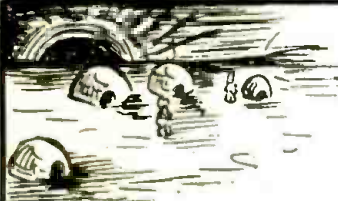

ALASKA



JAPAN



HAWAII



RUSSIA



MEXICO



EGYPT



SOUTH AMERICA



AFRICA

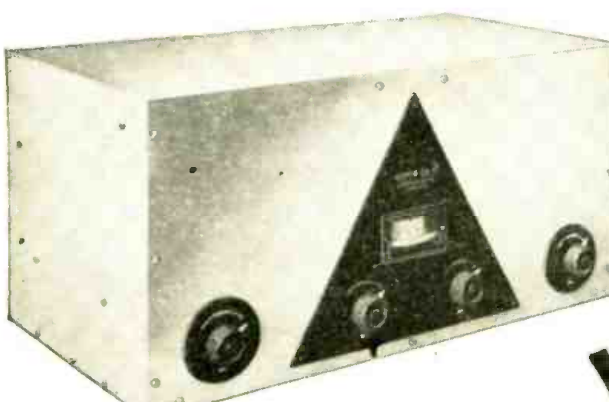

*Size: 9 x 19 x 10 inches.
Weight: 30 pounds*

**ENTIRELY NEW
ADVANCED DESIGN
NEW PENTODE TUBE
SENSATIONAL DISTANCE
RANGE 14-90 METERS
RELIABLE PERFORMANCE
A-C AND D-C MODELS**

Adaptable for long waves

Write, telephone or cable **TODAY** for
Complete Information

NORDEN-HAUCK, INC.
ENGINEERS

5 South Street PHILADELPHIA, PA., U. S. A.

HUGO GERNSBACK
EDITOR

AUG. - SEPT.
1930



H. WINFIELD SECOR
MANAGING EDITOR

VOLUME 1
NUMBER 2

Short Wave Opportunities

By HUGO GERNSBACK

DURING the past two years there has been greater activity in short-wave radio, perhaps, than in any other branch of the radio art. While short waves themselves are nothing new on the radio horizon, yet it is most interesting to note that the general public is, at last, becoming aware of the fact that there are such things as short waves.

From 1908 till 1921, radio was a sealed book, so far as the public at large was concerned. Then, when broadcasting started its triumphant progress in 1921, the general public became interested, and a tremendous boom in radio followed.

It seems certain that we are to see history repeated, so far as the short-wave receiver is concerned.

Until quite recently, it was not possible for the untrained layman to buy a short-wave set and operate it himself; and, indeed, until a few months ago it was not possible to buy an A.C. short-wave set.

These conditions, however, are being overcome very rapidly; and the time is now here when the public at large is beginning to ask questions about the possibility of listening in to short-wave stations thousands of miles away.

Until very recently, it was necessary to use the headphones when listening to short-wave programs; but, during the last year or so, it has become possible to bring in, on the loud speaker, the distant programs on the short waves, just as clearly as with the regular nearby broadcast programs.

It is no longer a novelty for people in America to listen in directly to 2LO of London (over G5SW of Chelmsford) or to PCJ in Holland; or even to a number of Javanese and Australian stations from eight to ten thousand miles distant.

Such things are everyday occurrences today; and a number of recent rebroadcasts of European programs—which were received in America on short waves and retransmitted on American broadcast waves by the National Broadcasting Co. and its associated networks—have aroused the general public as perhaps nothing else did that has happened in radio in recent years.

Of course, it will be many years before there will be hourly rebroadcasting by our own broadcast stations of the foreign programs; and it is doubtful that this feature will ever become quite general. In order to rebroadcast a program with faultless quality, atmospheric conditions must be absolutely right, and electrical conditions must be ideal.

But the man who operates his own short-wave set does not require 100 per cent perfect reproduction in his programs and, indeed, it gives him a far greater thrill to tune

in foreign programs directly on his own set than to listen to rebroadcasts over his regular set.

But the important message which I would like to broadcast to all radio enthusiasts, whether professional or otherwise, is the following:

There are now available on the market either ready-made short-wave sets, or sets in kit form, which can readily be sold to the public during the coming year. It seems quite likely that none of the large set manufacturers will attempt to sell short-wave radio sets on a large scale, as they do with regular broadcast receivers; and it is here that the professional radio man can reap his harvest. All that he requires is a good set which, when properly demonstrated to a prospect, will almost invariably result in a sale.

In other words, when the radio man makes a call on a radio set owner, he should find out by tactful questioning if his prospect is interested in receiving foreign programs from Europe or from other parts of the globe.

The important point to mention is that the type of set needed for this purpose is quite low in price, considering everything, and that a demonstration will be gladly made in the prospect's own house. This is also comparatively simple, because the prospect has already an antenna and ground and his own batteries to operate the short-wave set. In case the set owner has an A.C. receiver, an A.C. short-wave model will, of course, have to be used by the salesman.

If the demonstration is well made, there is no question but that the professional radio man can dispose of quite a good many short-wave sets.

Or, if it is not desired to sell the prospect in his own home, it is then a good idea for the professional man to rig up a set on his own premises, and send out invitations to his prospects to come and listen in to foreign short-wave programs, at certain times of the day. This is always a good drawing card, and many sales can be made in this manner.

At the present time, it is still necessary (with the majority of short-wave sets) to plug in different coils for the different wavelengths. But radio history is being rapidly made and, in forthcoming issues of *SHORT WAVE CRAFT*, we will present to our readers a number of new developments whereby it is now possible with a single set of inductors—which need never be removed from the set—to tune in to all wavelengths between 20 and 200 meters.

It should be noted that the surface of short-wave possibilities has as yet not been scratched; and that, sooner or later, we will certainly have a real boom in short-wave radio. Now is a good time to prepare for it, and lay the ground-work for what is to come.

SHORT WAVE CRAFT IS PUBLISHED ON THE 15th OF EVERY OTHER MONTH

THE NEXT ISSUE COMES OUT SEPTEMBER 15TH

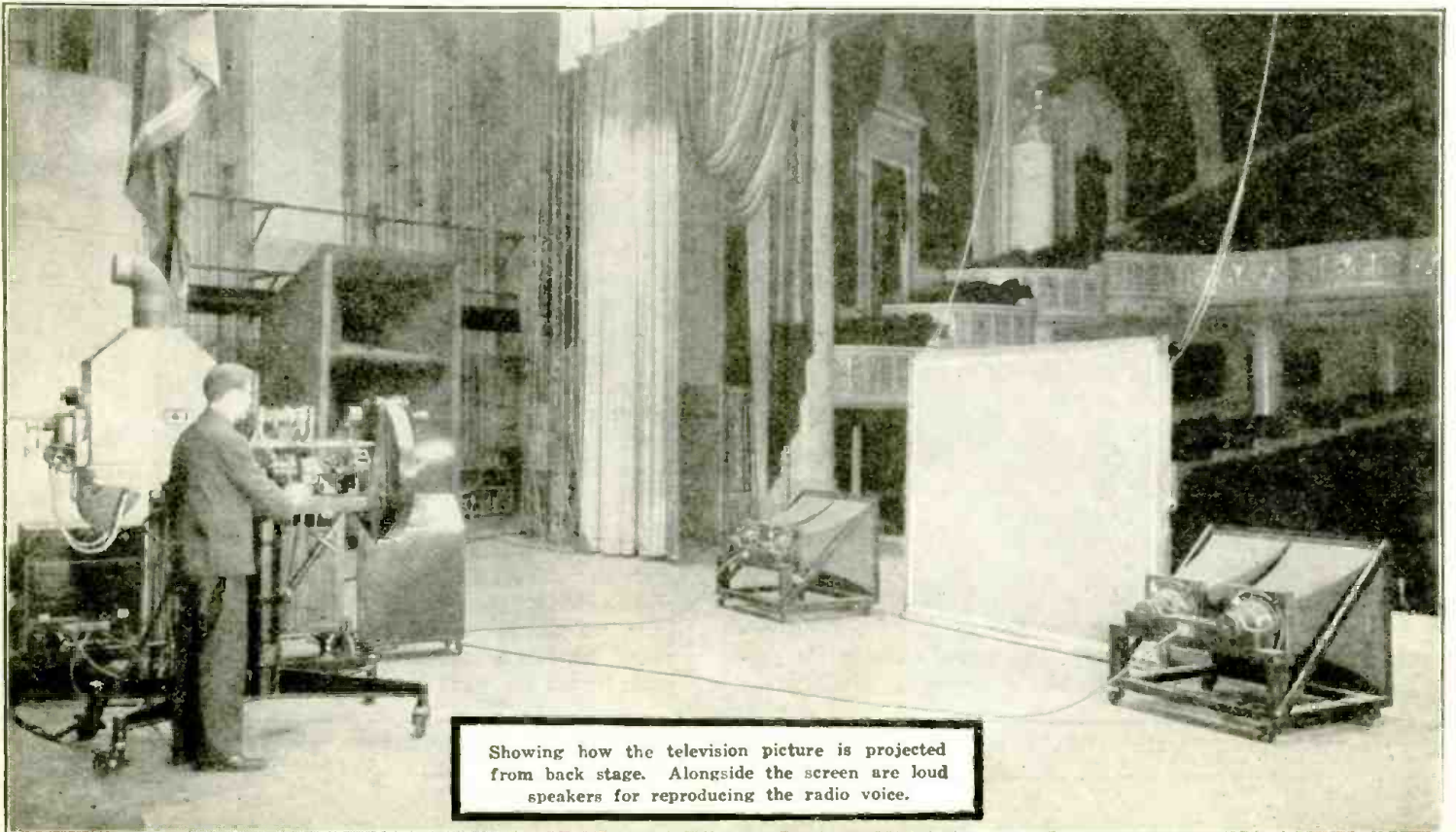
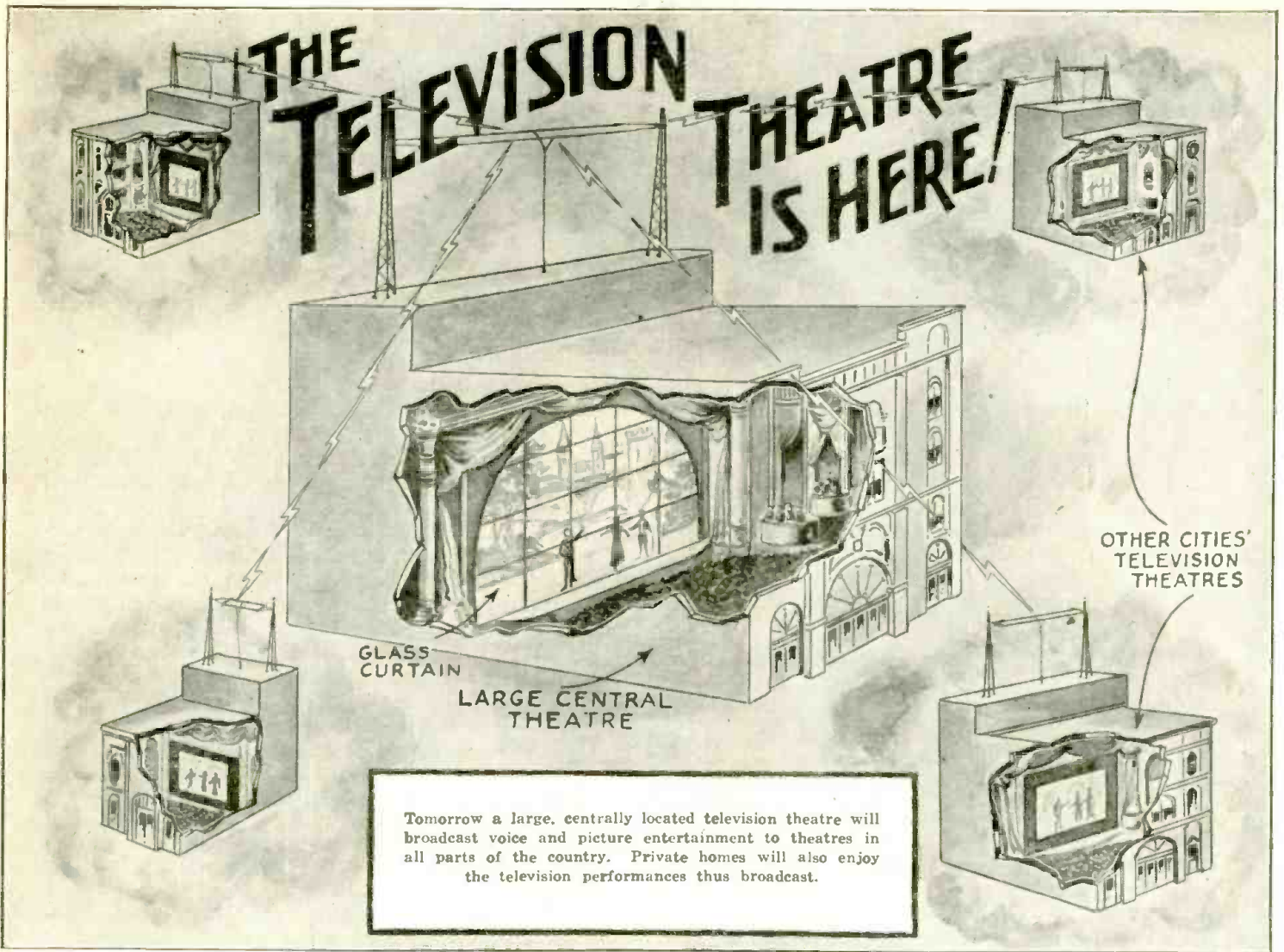

LARGE SIZE TELEVISION IMAGE

Demonstrated
by
Dr. Alexander
in
Public Theatre

Dr. E. F. W. Alexander, consulting engineer of the General Electric Company and the Radio Corporation of America, is shown standing alongside of his latest "brain child," the theatre television projector.

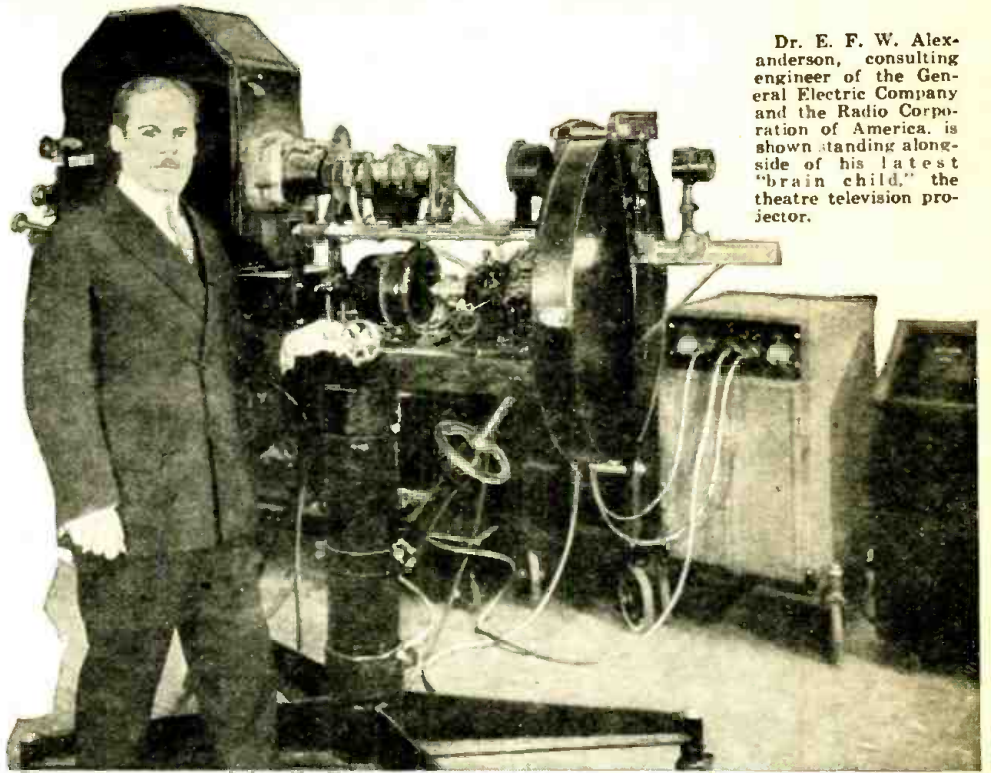

TELEVISION images transmitted by radio were publicly shown on May 22nd as a part of a regular performance at the R-K-O Proctor Theatre in Schenectady. It was the first appearance of television in the theatre, and was presented to show the possibilities of the new art as a medium of entertainment. Through a loud-speaker system the voices

Projector Lens System

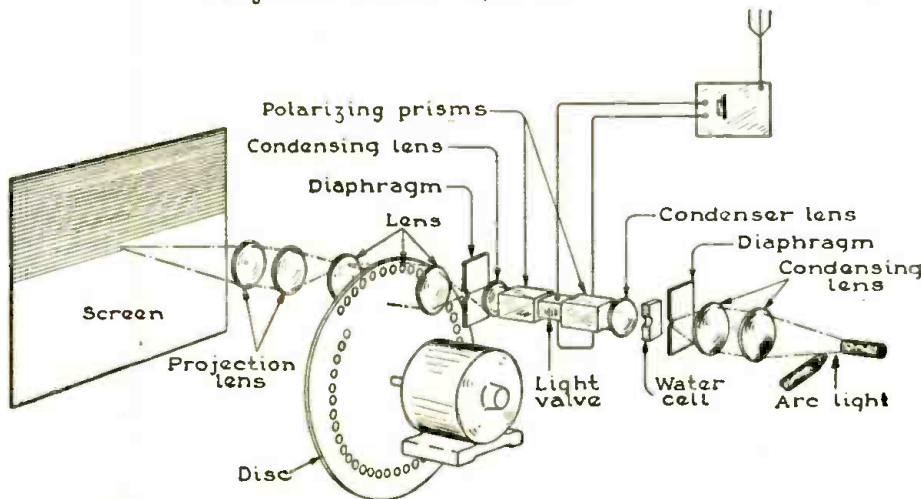

This diagram shows the paths of arc light beam through lenses, diaphragms, polarizing prisms and the famous Karolus light valve, together with the scanning disc.

shoulders only were shown.

The performers appeared before the television camera in an improvised studio in the laboratory of Dr. Alexander at the General Electric plant. Light impulses, converted into electrical impulses, or radio signals, were sent out by a transmitter in the laboratory on a wavelength of 140 meters. A microphone close to the artist picked up his speech and song, and converted the sounds into electrical impulses which were carried by wire to a short-wave transmitter at South Schenectady, from which point they went on the air on a wavelength of 92 meters.

At the theatre R. D. Kell, assistant to Dr. Alexander in television research, in the role of control operator, received the picture or light impulses, reproduced them on a small monitor "telecticon" and then transferred these impulses to the light-valve, at which point the light was broken up to produce

of the performers, also transmitted by radio, were heard by the audience.

The active images of performers were reproduced on a screen six feet square and were readily visible by those seated in the back rows of the balcony. The system used is one developed by Dr. E. F. W. Alexander, consulting engineer of the General Electric Company and the Radio Corporation of America, a pioneer in the development of television and its kindred art—radio.

Audiences at the afternoon and evening shows saw the musical director, John Gamble, lead the orchestra; the musicians were in their customary position in the pit but the director, a mile away, hearing his men over a telephone line, was present only in image. Merrill Trainer, laboratory assistant of Dr. Alexander, was seen and heard as he explained the method by which the images reached the theatre. Other performers, who were appearing in vaudeville numbers on the stage, were seen later in the same acts via television. Head and

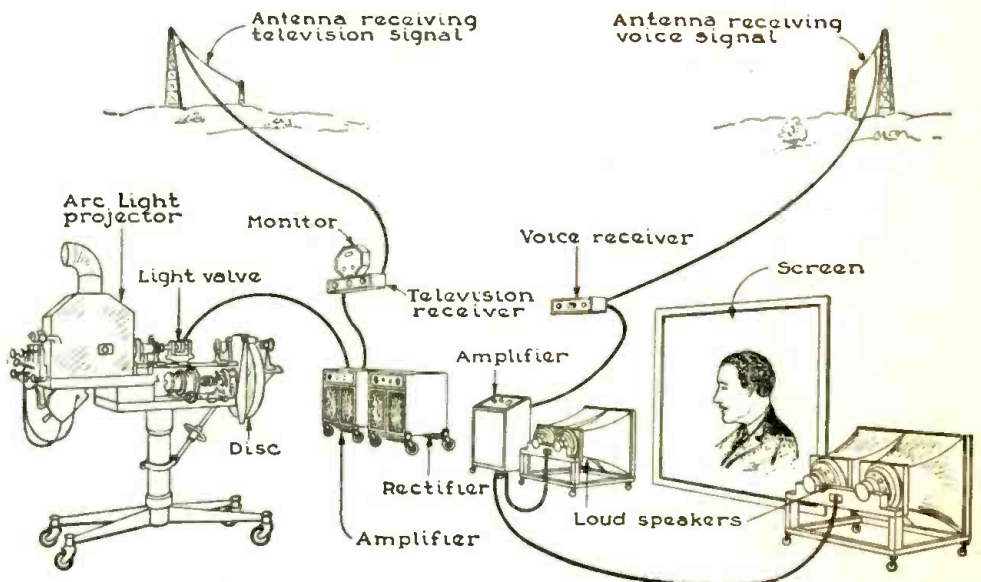

The apparatus as set up in theatre in a recent demonstration: the voice and television picture signals were picked up on separate aerials, and each of the currents amplified through its own amplifier.

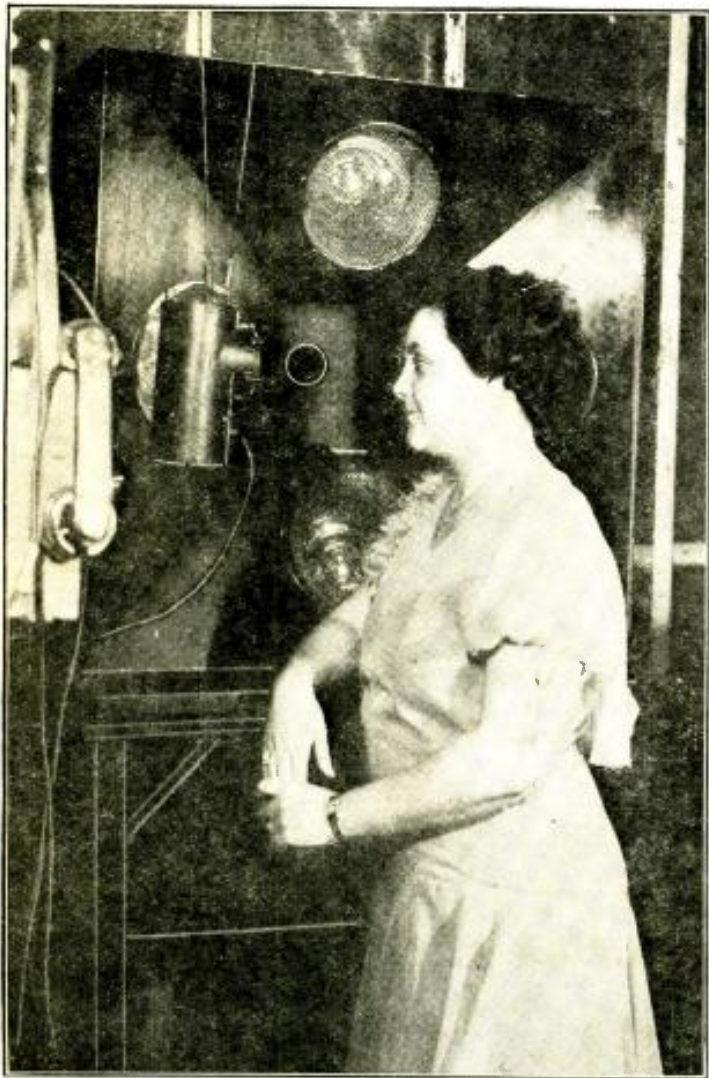

One of the entertainers whose facial likeness and voice were transmitted by radio and then picked up and reproduced on a large screen in a theatre in Schenectady, New York. The microphone is seen suspended in front of the performer, while the four large photo-electric cells are observed with their screen guards. These screens are grounded and serve the purpose of shielding the photo-electric cells from undesirable electrical effects.

an image corresponding in every detail to the subject at the studio. A second receiver picked up the sound signal and fed it into the reproducers which converted the electro-magnetic waves into sound.

The size of the image produced is a distinct advance over any previously shown. Dr. Alexanderson's first demonstration, three years ago, was a picture in a three-inch aperture. Last fall, at the Radio Show in Madison Square Garden, New York, an image fourteen inches square was exhibited.

The image was not simply black and white, on the order of a silhouette. All the gray shades between black and white were reproduced, registering every shadow and shade of the features and giving both depth and detail to the image.

Methods of Transmission and Reproduction

In radio broadcasting, the frequencies of speech and music modulate the current sent out from the antenna. In television, the antenna radiation is modulated by a succession of light impulses.

In the television studio, the method employed was similar to that used by Dr. Alexanderson in previous demonstrations. The subject to be televised stands before an incandescent lamp. Between the subject and the light is a metal disc about the size of a bicycle wheel and

drilled with forty-eight holes; the revolving disc throws a light spot which covers the complete subject twenty times

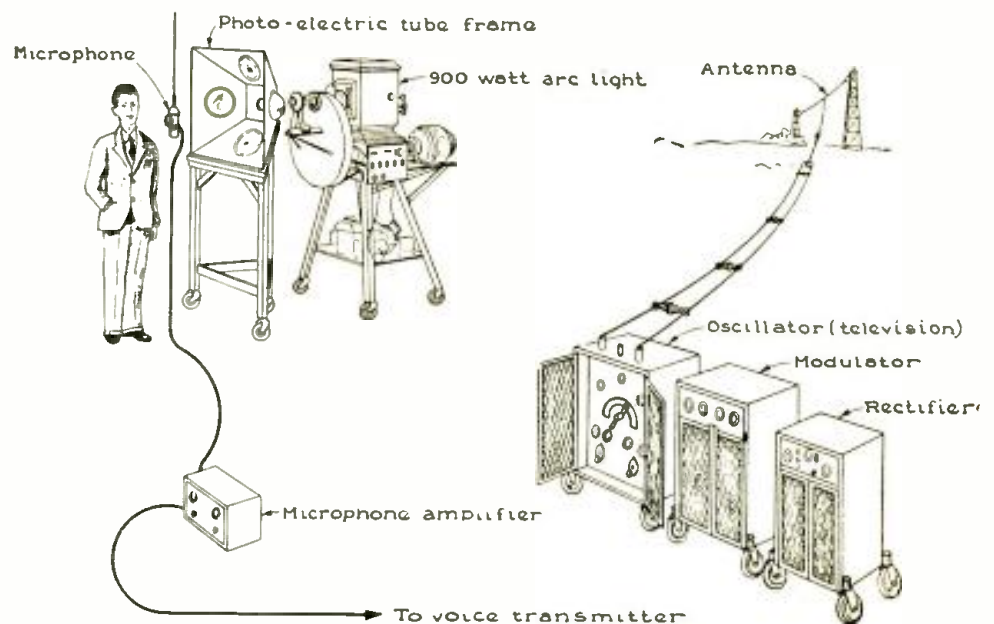

The set-up of the Alexanderson television transmitter in the studio, located some distance from the theatre. The scanning disc in front of the arc light causes a light beam to scan the face of the subject repeatedly, the reflected light beams acting on the photo-electric cells; the corresponding fluctuations in the photo-cell current, suitably amplified, are sent out as radio waves from the antenna shown and are then picked up by radio receiver and aerial at any desired point.

per second (that is, there are twenty complete pictures made up of light and shade). A large square frame contains four photo-electric tubes, which respond 40,000 times per second, to the variations of intensity in the light reflected back from the subject, with corresponding electrical fluctuations, which are amplified and used to modulate the broadcast wave.

At the theatre the electrical impulses were received and passed on to a "light valve,"* based on an invention by Dr. August Karolus of Leipzig, Germany. The light-valve is in the middle of an intricate lens system, in front of a high-intensity arc lamp, of a type similar to those used for the projection of motion pictures. The light-valve operates delicately and accurately to permit the passage of light, in exact correspondence to the impulses received from the television transmitter. The light thus passed is projected through lenses to a disc corresponding exactly in the number of holes and rate of rotation, to the disc at the camera or originating point. Additional lenses pass the light forward to the screen where these light impulses, at the rate of 40,000 per second, become the living, active image of the subject.

The arc lamp, with the lens system and the light-valve, the whole making up the television projector, is placed seventeen feet back of the screen. Heavy

*The Kerr effect (twisting effect on the polarized beam) in the light-valve is produced by a potential of 2,600 volts and a current of only 1 milliampere, thanks to the use of nitro-benzol in the chamber containing the two condenser (metal) plates shown in one of the accompanying diagrams. If carbon disulphide had been used, a potential sixty times as great would have been required, or a voltage of 156,000. The Kerr effect can also be produced by passing the modulating current through a coil of wire wound around tube containing the nitro-benzol, and the polarized light beam passed through the tube. Nicol prisms and lenses are necessary in any case.

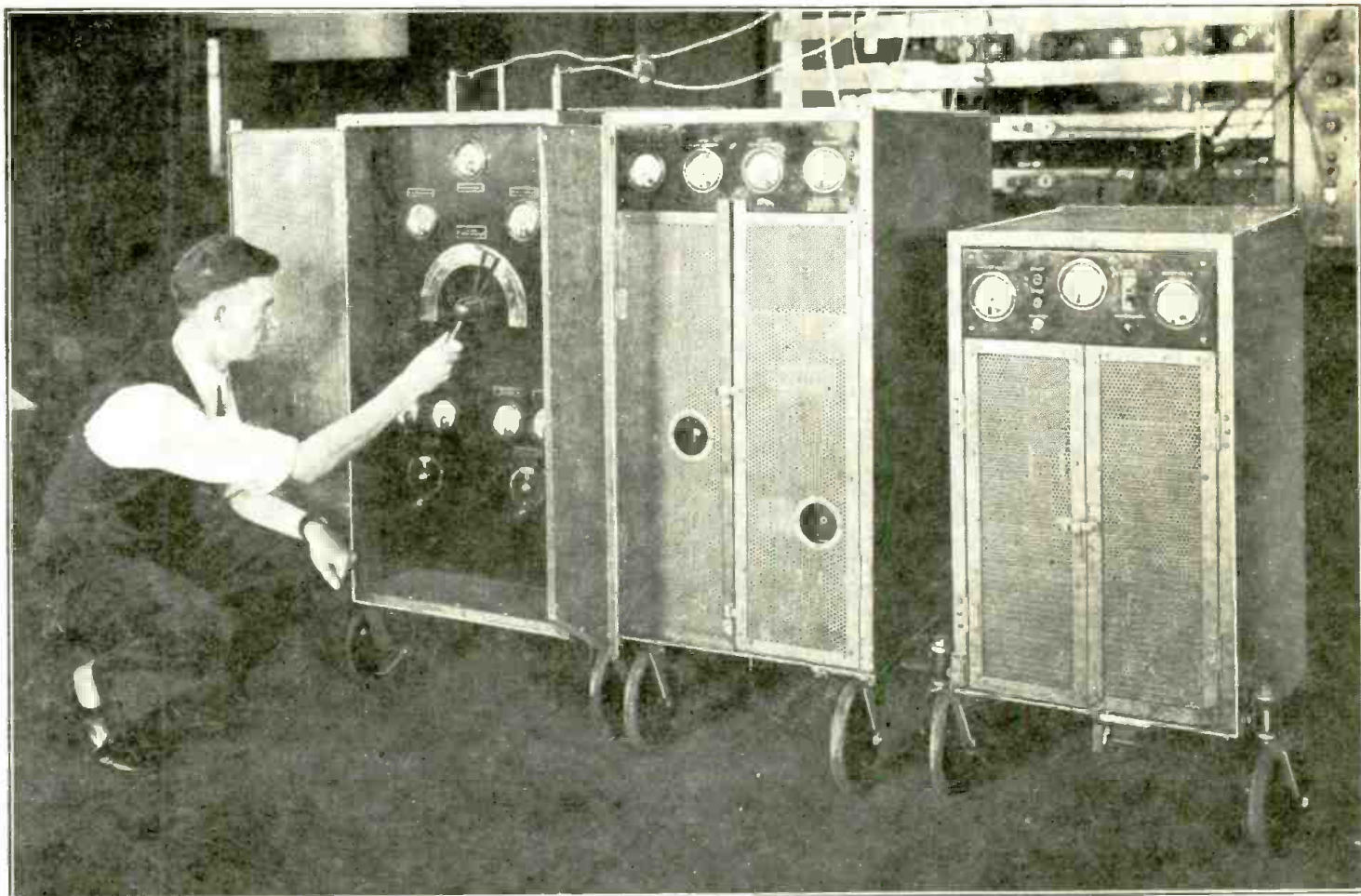

Transmitter of station W2XCW operating on 139.5 meters in sending out television signals from laboratory of Dr. E. F. W. Alexanderson, General Electric Co., Schenectady. Units, left to right, are: power amplifier, modulator and rectifier.

black cloth, draped from the projector to the screen, makes an effective light-proof tunnel which eliminates the possibility of stray light falling on the screen. All the elements in the system

(including the projector, amplifier and loud speakers) are mounted on wheels to permit assembly and disassembly when used as part of a vaudeville program.

INPUT FROM TELEVISION AMPLIFIER

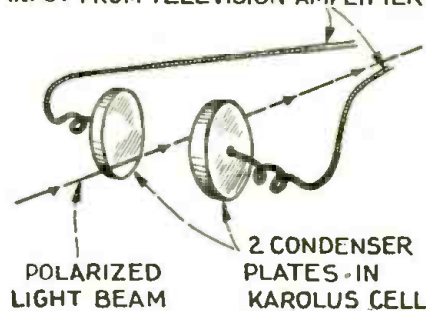

Schematic diagram showing arrangement of two condenser plates in the Karolus cell or "light valve."

"For fifteen years radio was simply an auxiliary to navigation," said Dr. Alexanderson. "In 1915 and 1916 we held daily communication by radio-telephone from Schenectady to New York. We found that many amateurs adopted the habit of listening in, and our noon hour of radio became the first regular broadcasting. But we had no idea what it would lead to. Our idea was to telephone across the ocean, and so we did at the close of the war; but we failed to see the great social significance of broadcasting. Television is today in the same state as radio-phony was in 1915. We must then fall back upon our conviction that the development of television is inevitable on account of the forces working in the scientific world today."

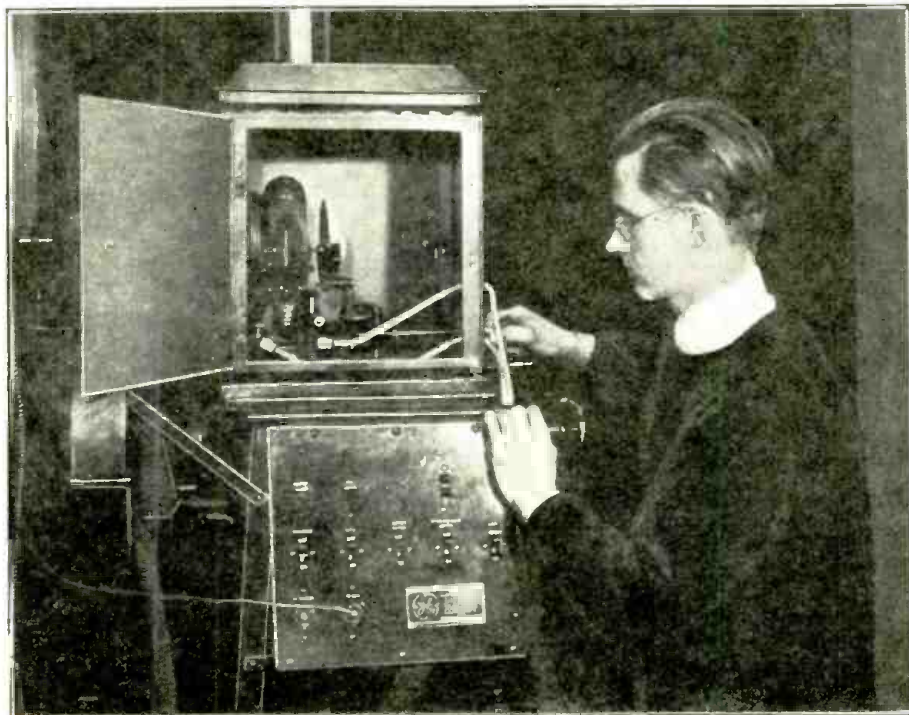

Incandescent lamp which shines on face of subject to be televised. The lamp case is shown open.

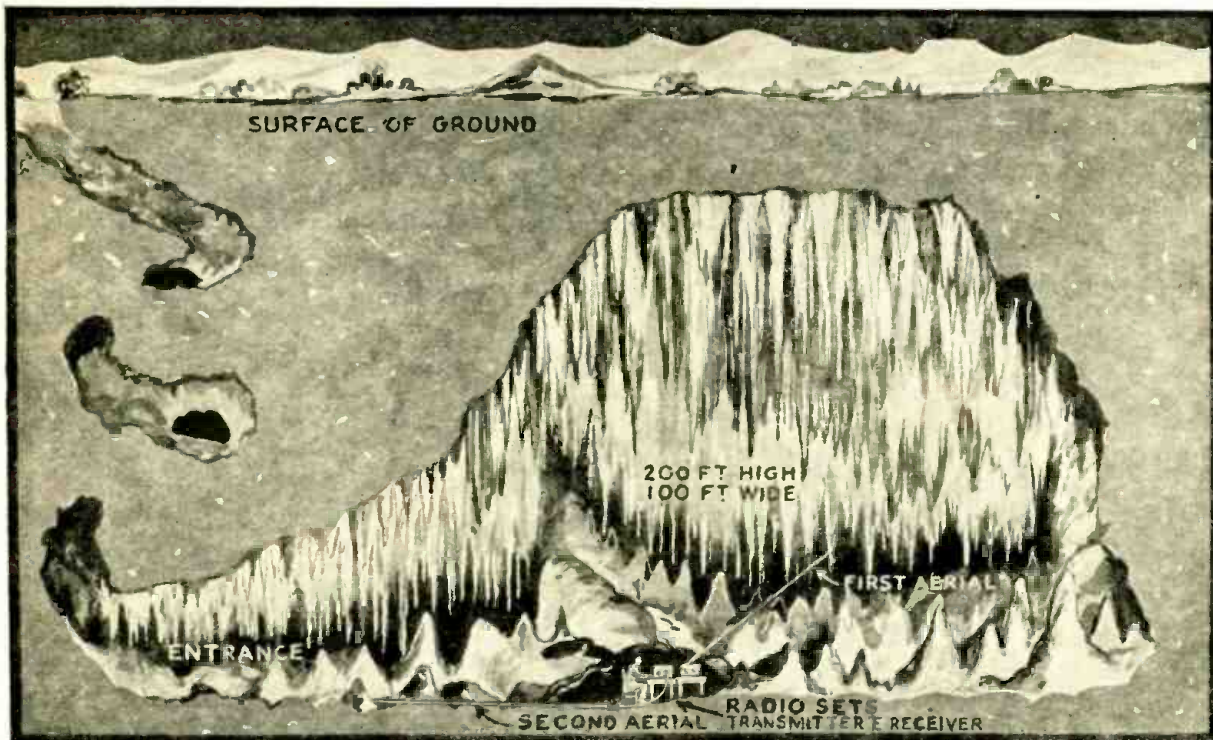

This picture shows how Mr. Palmer, youthful short-wave expert, set up his transmitting and receiving sets in one of the chambers of Carlsbad Cavern in New Mexico. The short-wave apparatus was located 400 feet underground and yet European stations were heard, and he "worked" a number of amateur short-wave stations.

My Short Wave Experiments

In Carlsbad Cavern

By ERIC PALMER, JR.

SIXTY millions of years ago, in all likelihood, there was no such thing as radio—and a true conception of the infancy of this marvelous science comes in the contemplation, when one glances at the lacelike wonders of nature which make the Carlsbad Caverns in New Mexico the most amazing underground recesses on earth. It therefore was positively awesome to sit in one of these ancient chambers, amid thousands of glistening formations, and to find that invisible waves were speeding through them from and to most distant points of the outside world. And the magic radio signal speeds around the earth eight times in a second; while it may have taken a thousand years to add a few inches to one of the onyx pendants in the depths.

It was no wonder that the prospect of tuning-in in such a location gave me one of the real thrills of my adventures in radio—and it proved even more exciting in the happening and memories thereof.

Just imagine: I was the first to install a radio instrument in a place that is considered by geologists the oldest of its kind. Doing something that has not been done in 60,000,000 years certainly gives one a peculiar feeling.

During the spring it was my great privilege to make rather intensive tests of radio reception in the Carlsbad Cav-

erns, covering a period of some weeks and under all conditions of outside atmospheric conditions. In brief, an extraordinary experience!

Short-Wave Apparatus 400 Feet Underground

Installation of radio equipment was not without difficulty. Constant dripping from stalactites made the caverns very damp. The apparatus was always in

danger of damage by moisture. It was finally placed on a table in a corner away from stalagmites—all comprising just a tiny speck in a colossal room more than 200 feet high and at least 100 feet wide—more than 400 feet below the surface—with gorgeous shapes at every turn perpetually glistening.

First I wired up the transmitter, generally made up of parts from my home station (W2ATZ, in Brooklyn), a 50-watt outfit with 1,000 volts on the plate, employing two Recto bulbs; nothing out of the ordinary was used. The receiver was the Grebe "CR18" Special, with detector and two steps of peaked amplification. The antenna was of the voltage-feed Hertz type favored by amateurs.

Carlsbad Caverns are in government hands. The property is now a national monument, and a number of the large rooms already explored have been supplied with electricity; so that the ever-increasing number of visitors might view the scenes. The Department of the Interior has employed Rangers as guides. With their permission I tapped the power lines, stepping up the 110 volts with the customary transformer. The only handicap was that the power was usually shut off at 4:30 o'clock; so that the radio tests were always in daylight and not at hours when a large number of experimenters on short waves would be counted on for listening in.

erns, covering a period of some weeks and under all conditions of outside atmospheric conditions. In brief, an extraordinary experience!

Short-Wave Apparatus 400 Feet Underground

Installation of radio equipment was not without difficulty. Constant dripping from stalactites made the caverns very damp. The apparatus was always in

A Stalactite Supports the Aerial

The short aerial was affixed to a stalactite. Another antenna was created by running an insulated wire all the way to the entrance of the cavern, with a condenser in series—and that resulted in great signal strength. But I heard some stations without any aerial at all; the coils within the receiver and the ground connection were sufficient.

Much to the surprise of everyone, stations rolled in the minute the receiver was connected up. The first heard was W2XAF, Schenectady. It was daylight in New Mexico, but the music came through nicely over the 2,400 miles. Next W2XE was reported; this is the short-wave auxiliary of WABC. WENR, Chicago, represented by W9XF, was logged, with tremendous volume.

Calls Station 1,500 Miles Away

Realization followed expectancy. It was obvious that the Hertzian waves were penetrating to the caverns. The next thing in order was to try out the transmitter. A CQ call on 20 meters was flashed out. I nervously awaited a response. In a few moments it came: W9BCT was calling W5QK, the designa-

tion assigned to me at the cave. A glance at the roster of amateurs showed that W9BCT is Neil B. Coil, at St. Paul, Minn., 1,500 miles from Carlsbad.

Probably I gave Coil the surprise of his life when I clicked out the information that I would have to shut down because the bats were flying about and making life rather miserable. He inquired for details. I told him that I was far underground.

He could not resist flashing "FB" (which means "fine business" in "ham" lingo). Later on a clipping from the St. Paul News reached me, containing the story he had phoned in with reference to his contact with the station in Carlsbad Caverns. That was news, true enough. Exchanging greetings with someone far under the ground, even with radio, is not being done every day.

Florida and California were heard calling—scores of stations, that very afternoon, and succeeding sessions at the key.

An Uncanny "Echo Effect"

One thing was noticed in reception from great distances—an *echo effect*. It was quite uncanny.

High-power commercial stations in South America were noticeable particularly because, on testing, their letter "V" sounded as if it was chasing itself about.

Probably I was listening to both the ground and the sky wave.

When the "V" came I actually came across two "Vs," the first strong, the second weak.

That meant, according to the accepted theory, that the sky wave was following a longer course, due to rebounding from the Heaviside Layer, the "atmospheric roof."

We Listen to England and Holland

On G5SW, Chelmsford, the British Broadcasting Corporation's high-frequency transmitter, the same thing happened—also with PCJ, Eindhoven, Holland. When words were spoken it seemed, several times, as if the speaker stuttered just a trifle. But that did not always happen—and G5SW and PCJ were noted about a dozen times.

What gave me an especial "kick" was when I brought in PY1AW. This is an amateur station which I myself have operated; it is located in Rio de Janeiro (Continued on page 168)



Here we see Eric Palmer, Jr., in his radio den at his home in Brooklyn, N. Y.

How Short Waves

Artificial Fever IN THE

Remarkable short-wave apparatus, developed in the Research Laboratory of the General Electric Co., induces heating effect in the body when it is brought under the influence of 21 to 30 meter waves. Frequency of waves used varies from 10,000,000 to 14,000,000 cycles per second. Brain action accelerated by short waves, research shows. Tomorrow we may use short waves to keep us warm, instead of furnaces.

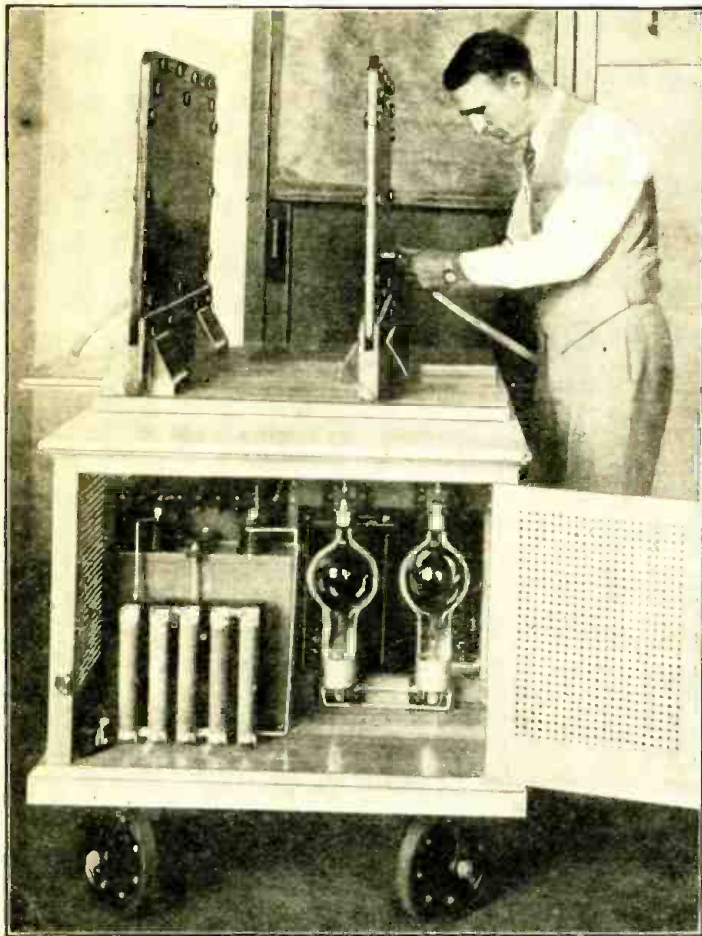

Left—One end of the "artificial fever" short-wave apparatus.

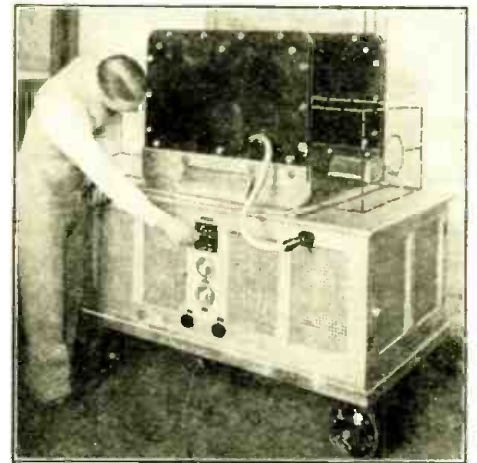

The wooden box in which patient is placed is indicated by dotted lines.

A NEW tool has been made available to the medical profession for investigations concerning fevers and their use in the cure of certain diseases. At a joint meeting of the New England Physical Therapy Society and the American Physical Therapy Association in Boston, on April 18, the apparatus was shown and described by Charles M. Carpenter and Albert B. Page of the Research Laboratory of the General Electric Company.

a short-wave radio transmitter, is featured by a tube which generates current oscillations at the rate of between 10,000,000 and 14,000,000 cycles per second (corresponding to those of 30- to 21-meter waves). This oscillating current is concentrated between two condenser plates, instead of being fed into an aerial, and the body to be heated is placed between the two plates.

Heat has been used throughout the history of medicine as a means of alleviating and curing diseases, and, more

The equipment, similar in principle to

recently, the causes and effects of fevers have been the subject of investigations and debates. Previously it was thought that fever temperatures were a sign of disease, just as pain is, and that the fever heat should be eliminated to make the patient more comfortable. Recent investigations, however, have indicated that, at least in the case of certain diseases, the fever is valuable in killing the germs of the disease; since many germs are unable to withstand the fever temperature of the human body.

The production of artificial fevers in the human body has been a difficult task, because man's temperature-regulating mechanism is so efficient. A fever results from a rise in temperature throughout the body, and local external heating is dissipated without raising the temperature of the whole body. Various methods of producing fever temperatures have been tried in the past; such as the use of hot-water baths and exposure of the body to artificially heated atmospheres. The injection of a protein re-

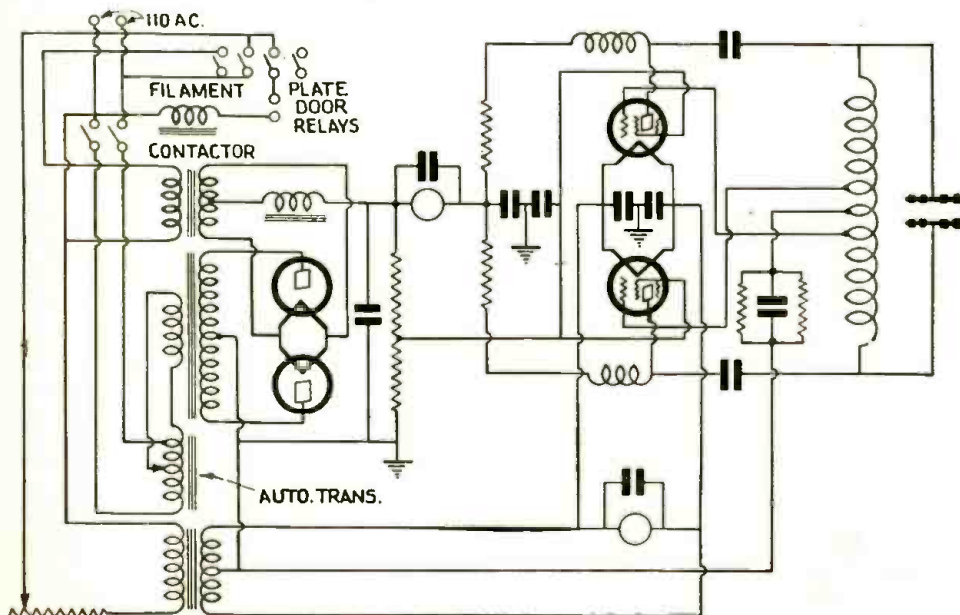

Hook-up of "artificial fever" apparatus.

Are Used To Produce and Other Effects HUMAN BODY

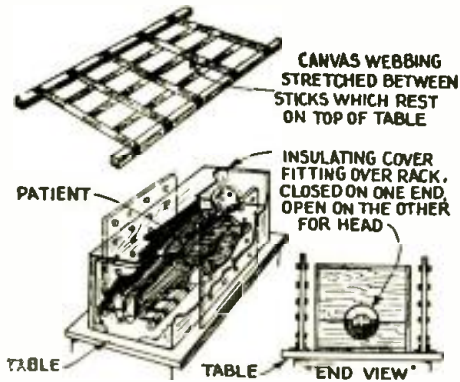

Wooden box and canvas webbing support for patient. Motor blowers circulate air in the box.

sults in a fever, and a high fever temperature for the treatment of paresis can be produced by the injection of malaria germs into the patient. The injection of a protein is hazardous because one is dealing with unknown factors and uncertain quantities, as Messrs. Carpenter and Page pointed out in their paper presented at the Boston meeting; the use of malaria or other germs often fails because of the immunity of the patient, and it is dangerous because a living virus has been introduced; while the hot-water bath and similar methods are time-consuming, difficult of application and not easily controlled. The new short radio-wave method, on the other hand, is at all times under control.

The Origin of the Idea

The development of the equipment for producing the artificial fever resulted from some experiments conducted by Dr. Willis R. Whitney, director of the Gen-

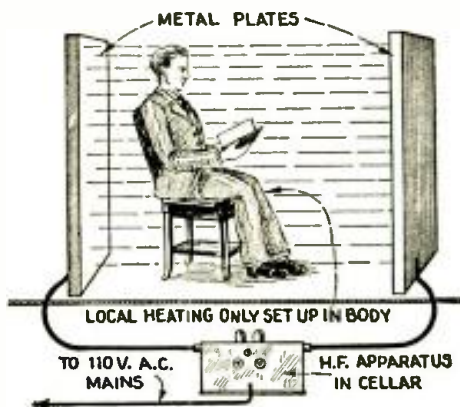

Tomorrow—instead of using furnaces we may heat "our body only" by sitting in a high frequency field.

The opposite end of the "artificial fever" apparatus—the engineer is holding one of the 30 meter oscillator tubes. It is a 4-element screen-grid tube, with an output of 500 watts.

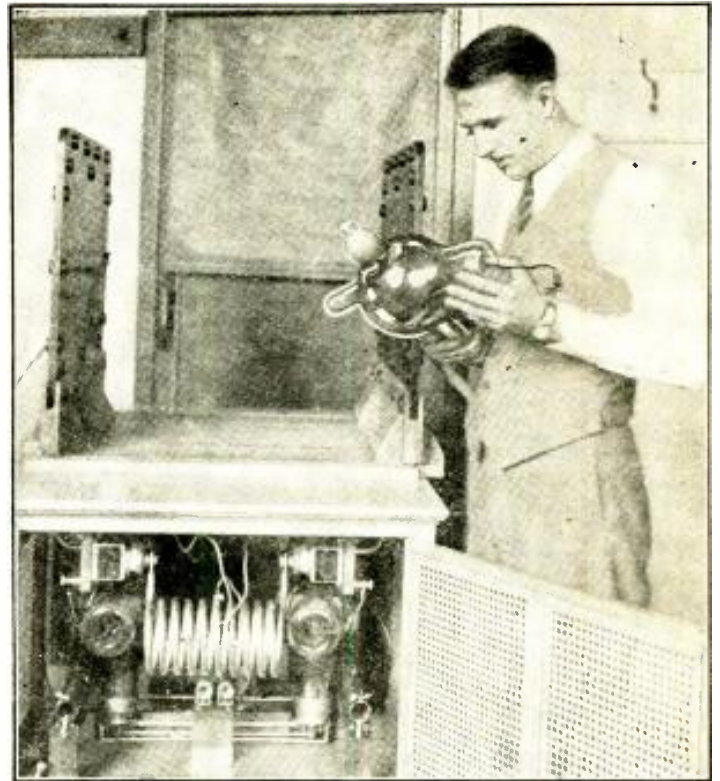

eral Electric research laboratory, and Mr. Page, when studying the effects of high-frequency induction coils on fruit flies and mice. Shortly after these experiments, it was noticed, the blood temperature of research men working in close proximity to vacuum-tube oscilla-

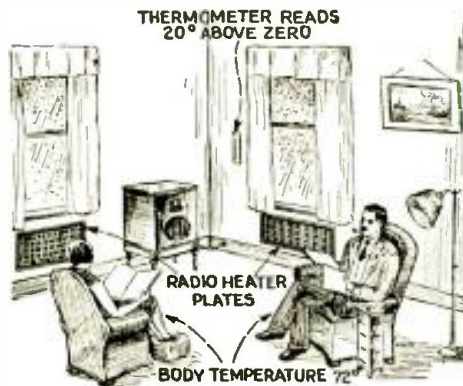

"Short-wave" heating tomorrow! Room temperature is only 20 degrees above zero—but the body heat is 72 degrees.

tors delivering six or eight kilowatts of 5- to 6-meter waves were slowly raised. It was known that various ways of producing fever heat have been applied to human beings for therapeutic purposes; so it seemed worth while to study experimentally the electric fever, since it seemed to carry with it no danger and no discomfort. In addition, when the current is off, the fever quickly subsides—in other words, it is controllable.

Various forms of electrical diathermy have been extensively used for years; but they are methods of direct application of electrodes to the body, and have certain limitations which are not present in this new apparatus. With the new equipment, which is essentially more

costly, it is necessary only to place the body, or that portion to be treated, in the space between two insulated plates, and the body temperature is raised at a rate and to an amount dependent only on the controlling or generating apparatus.

"If there is merit in artificial fevers," says Dr. Whitney, "it seems worth while to study carefully the electrically-induced fever. If there are infections whose temperature tolerance is less than that of the host of the infection, it may be possible to destroy the infection. It is also customary to bake out, or heat by various means, stiff joints. As the radio method produces the heat within the tissues themselves, because of the electrical resistance of the body fluids, it seems probable that this method of applying heat should be studied in member and joint diseases."

Description of the Apparatus

The apparatus shown at the Boston meeting is enclosed within a case about 3 feet high, 3 feet wide and 6 feet long, mounted on small wheels so as to be portable. It is like a short-wave radio transmitter, except that the energy is concentrated between two condenser plates instead of being directed from an aerial. The heater consists of a vacuum-tube oscillator, with a full-wave rectifier which supplies the high voltage needed. The oscillator comprises two 500-watt vacuum tubes operating at a frequency of from 10,000,000 to 14,000,000 cycles; their output is concentrated between two plates mounted vertically on top of the cabinet. The rectifier, which changes the low-voltage A.C. house supply to direct current for use in the vacuum tubes, has an oil-immersed transformer with a 7,000-volt secondary which feeds

(Continued on page 162)

Jenkins
Television
System
is
Publicly
Demonstrated

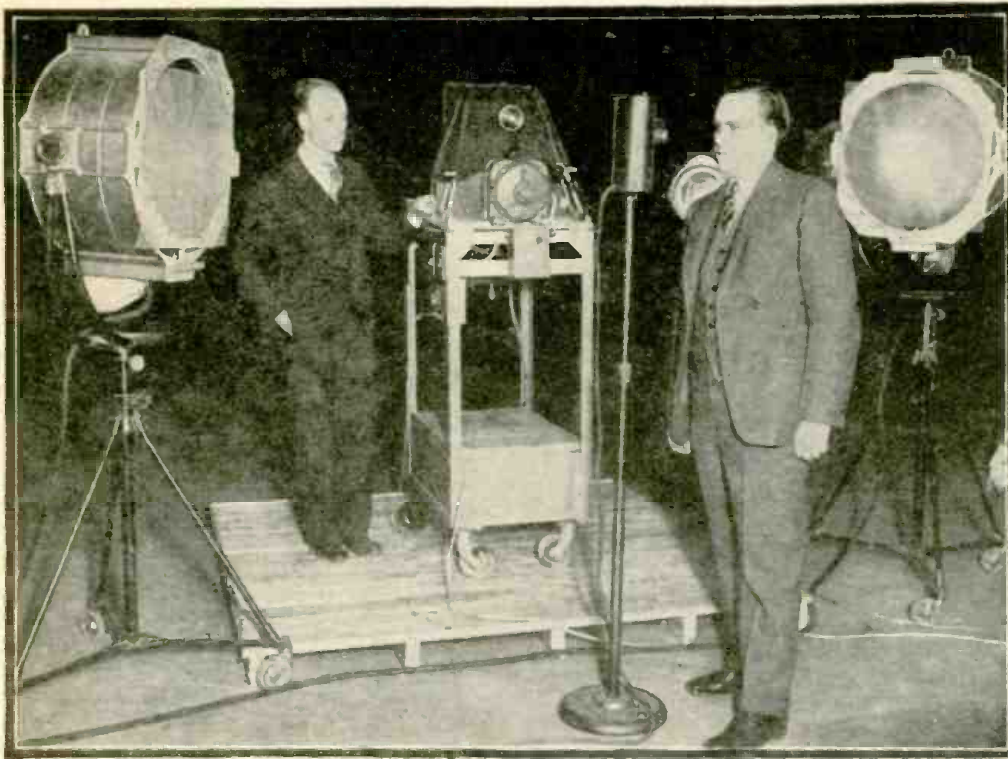

In a recent public demonstration of the Jenkins Television System, during which a facial likeness was transmitted on one wavelength, and the voice on another, through a separate transmitting station, very excellent results were obtained in the complete transmission and reception of the living image. Above we see two searchlights with filters, which throw their converging beams on the subject standing before the microphone; in the background is the television camera.

Picture at right shows the Jenkins television transmitter for sending movies via radio waves. The television amplifier with its amplifying tubes and meters for reading the current and voltage passing through the amplifier circuits is shown at the left. The arc light and scanning disc are observed at the right of the picture.

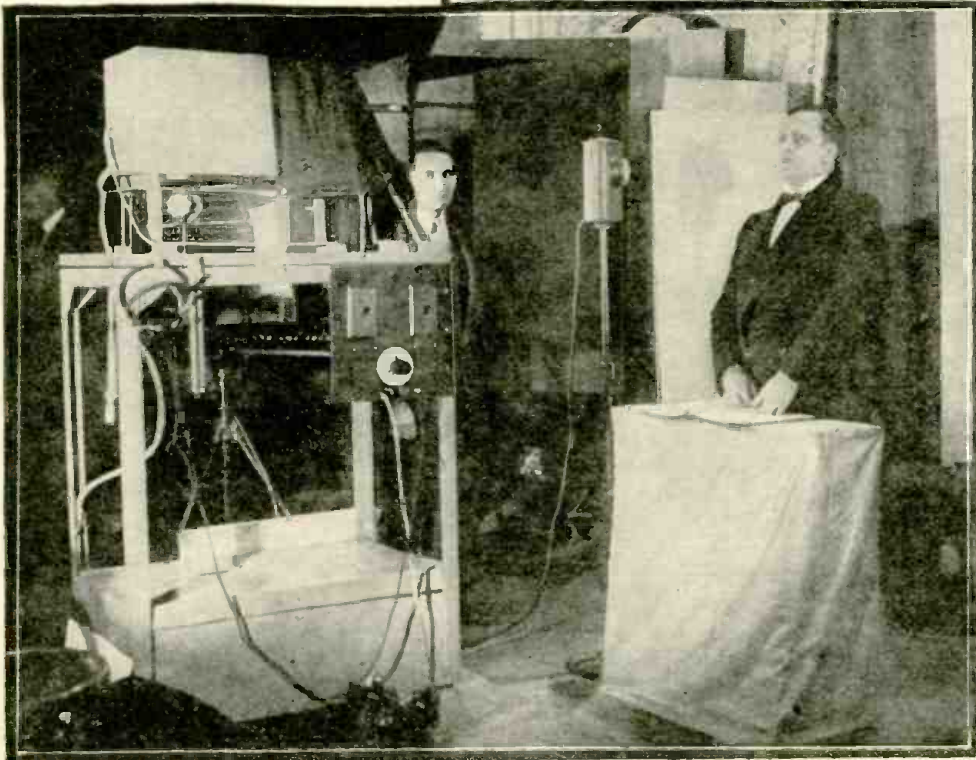
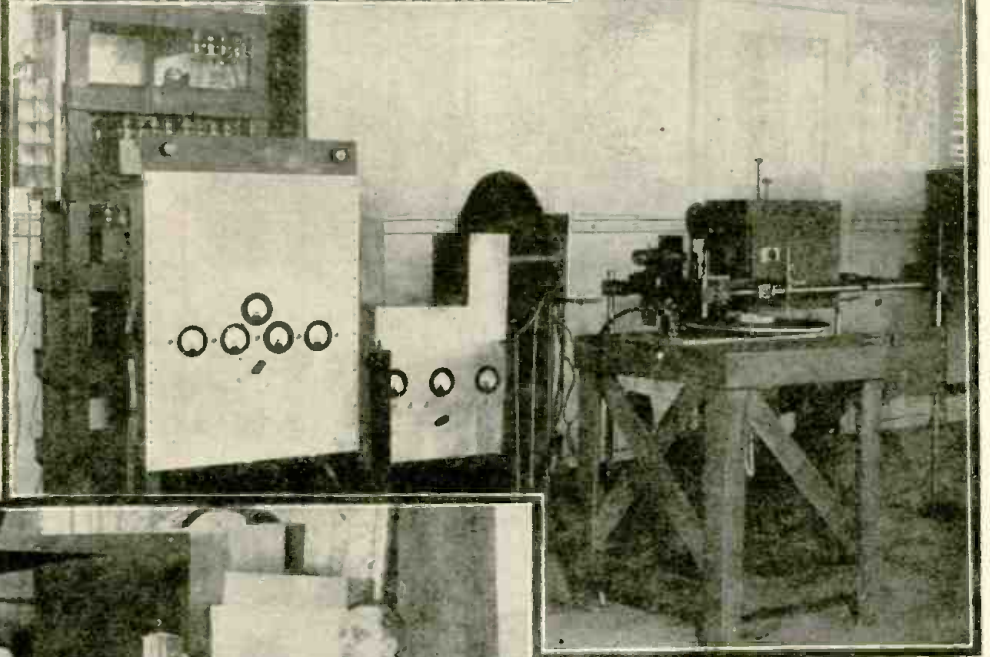

At the left we have another view of the Jenkins television transmitter, used in a recent public demonstration at Jersey City, New Jersey. Improved results were obtained at the receiving stations, a number of which were located in various parts of the city. Many private experimenters, who had television receiving apparatus fitted with scanning discs containing the proper number of holes, were successful in picking up the Jenkins television images. Many prominent people appeared in the television studio and had their faces and voices transmitted by radio. This picture shows the scanning disc and photoelectric cell box. The lights which illuminated the speaker's face are observed in the picture at the top of this page.

TELEVISION *on* SHORT WAVES

By D. E. REPLOGLE*

Television is rapidly developing toward a practical stage, and in this article by Mr. Replogle we learn about some of the interesting and important technical considerations that must be kept in mind in designing and building a suitable amplifier for receiving television signals. The proper number of amplifier stages to use is discussed; also the method of adjusting the scanning disc to synchronism and framing the picture image.

THERE are now some ten or twelve stations, scattered throughout the country, which broadcast television signals on a schedule basis. The quality of these transmissions is such as to give genuine entertainment value to those experimenters who desire to "look-in" at the pictures transmitted. Although television, as it stands today, is admittedly crude in form, the present situation is far superior to that of two years ago. The brief sporadic interest of that time, and the ill-timed publicity which started it, most certainly did more to retard the advancement of the art than to further it. Ill-conceived and poorly-constructed equipment was foisted upon the public at that time; broadcast stations promised programs which they were incapable of transmitting; and, in the fiasco following, television died—so far as immediate public response was concerned. Today, conditions are different. Experimenters realize that highly-specialized circuits are essential to the reception of the signal, and that distances covered with a given input power are considerably shorter than with sound.

100- to 150-Meter Waves Used

The television transmitters now in use operate, for the most part, in the band between 100 and 150 meters. Certain bands, however, have also been set aside in the ultra-high-frequency spectrum for work of an entirely experimental nature. Recent rulings by the Federal Radio Commission permit the use of a television signal by amateurs in the band between 150 and 200 meters also. The interest at present evidenced by transmitting amateurs indicates that, within a short time, this band will be thoroughly filled by amateur television signals. In the present state of the art, there is no reason why these men cannot make valuable contributions toward the future development of television.

In analyzing the circuit requirements for perfect television reception, we must first investigate the frequency requirements. As a standard, let us take an image of 48 horizontally-scanned lines, repeated 15 times per second; this fre-

quency of repetition corresponds to a disc speed of 900 r.p.m. This picture is scanned from left to right and from top to bottom, as in reading the usual printed page. With a picture having the shape ratio of the standard motion-picture film, the degree of pictorial definition with a square scanning aperture will be 64 elements in a horizontal line. The highest frequency transmitted under

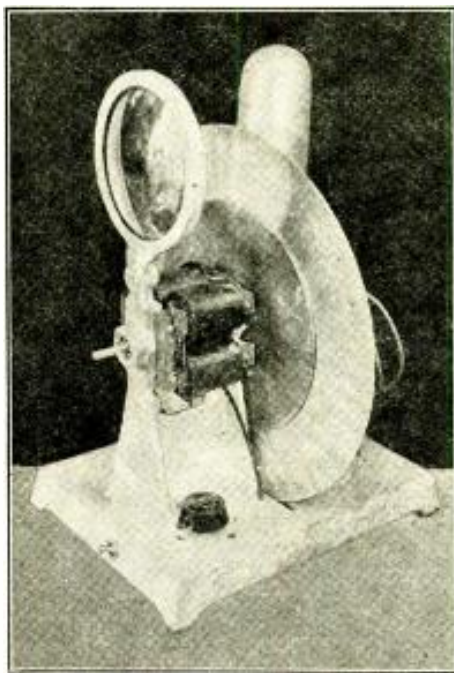

The Jenkins commercial radiovisor from the front, showing the "eddy-current coils" and lens magnifying the reproduced image. This is the "home" type machine.

these conditions is half the total number of picture elements multiplied by the picture frequency: or,

$$\frac{48 \times 64 \times 15}{2} = 23,240 \text{ cycles.}$$

Our reason for dividing by two is that it takes one complete variation from maximum to minimum through two elements to correspond to a complete A.C. cycle. The lowest frequency encountered is the picture frequency—15 cycles. The audio-frequency amplifier shown in Fig.

1 has been designed to pass all frequencies from 15 cycles to well beyond 30,000 cycles, without discrimination; as shown, it is to be used in conjunction with "grid-leak" detection.

In "bias" or plate-circuit detection it is necessary to employ an even number of A. F. stages and, since four stages would be too unstable, we must make provision for a higher level of output from the detector tube and drop one A. F. stage.

The reason is that, in passing through a vacuum tube, the signal is shifted in phase by 180 degrees. This corresponds to a complete reversal of the picture—maximum light intensity becoming minimum—and a "negative" picture results. The audio-frequency component, therefore, must pass through an even number of such reversals, if a positive picture is to result. In "grid-leak" detection the rectification takes place in the grid circuit and one such displacement occurs before the A. F. amplifier is reached. With "bias" or "plate circuit" detection this does not occur and, in consequence, we employ an even number of audio-frequency stages.

Output Stage Made Adjustable

In order to adjust the character of the received image, the plate and grid voltages of the output tube are made variable; this makes it possible to adjust the current through the Neon tube, so that any required degree of initial brilliancy may be attained with the tube still biased so as to work on a favorable portion of its characteristic curve. There is one word of caution to be said regarding the operation of the output tube. It will be noticed that the applied plate voltages are far in excess of those specified for the tubes. This is because the filtering resistances in the intermediate stages cause a voltage drop which must be compensated. In the case of the output tube this voltage drop is caused by the Neon tube, which has a D.C. resistance of the order of 10,000 ohms. If a loud speaker is to be employed with the receiver, an 8,000-ohm resistor should be inserted in series with the coupling device, to prevent damage to the tube, which will positively occur if this warning is unheeded. If full volume
(Continued on following page)

*Mr. Replogle is Assistant to the President, Jenkins Television Corporation.

The Fair Sex Enjoy Jenkins' Television Demonstration

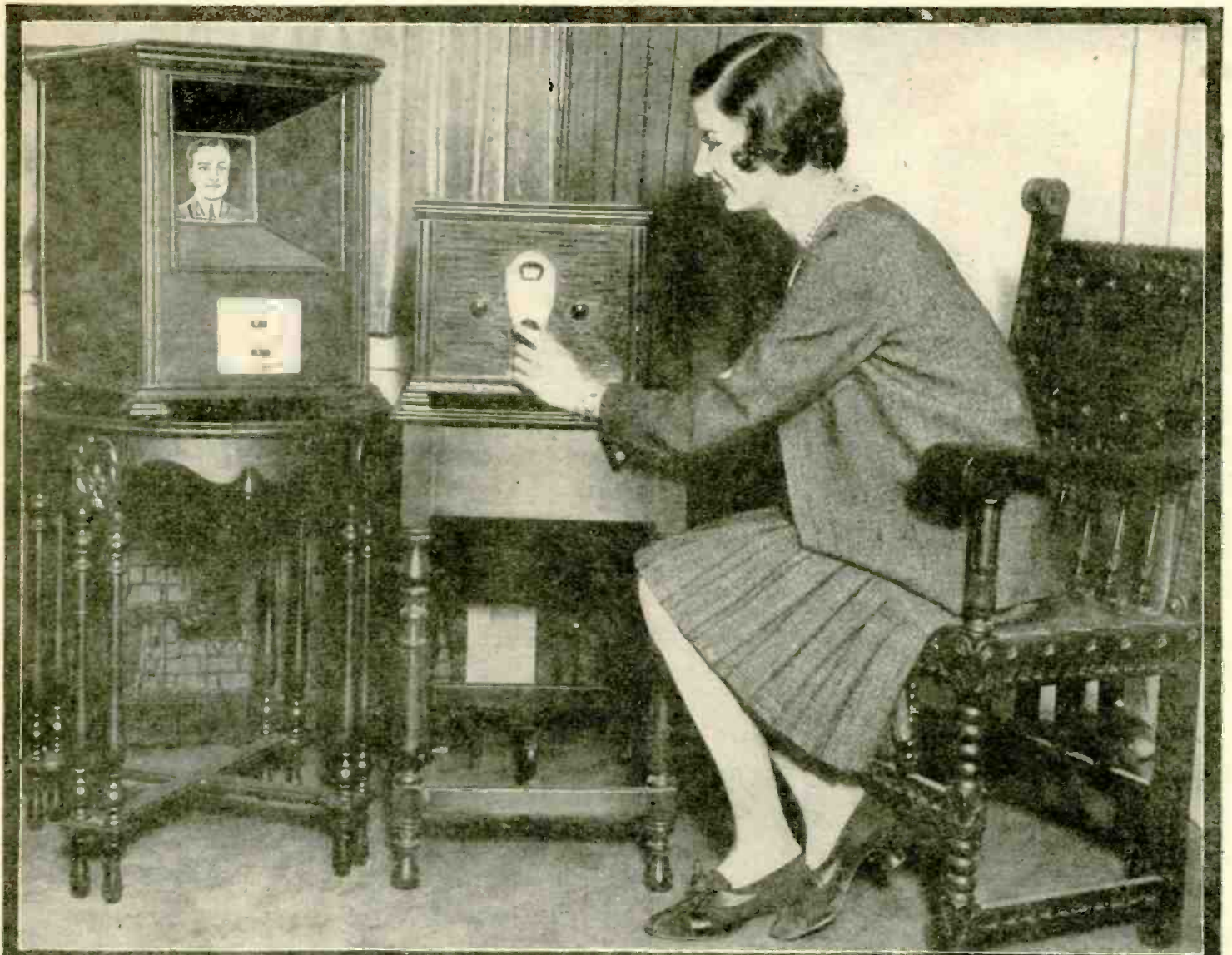

Above: Tuning in the image on the special Jenkins Television Receiver.
 Below: The chassis, which uses five screen-grid 224 tubes, one 280 rectifier tube and one 245 power tube. A scanning disc and neon tube are used to form the image.

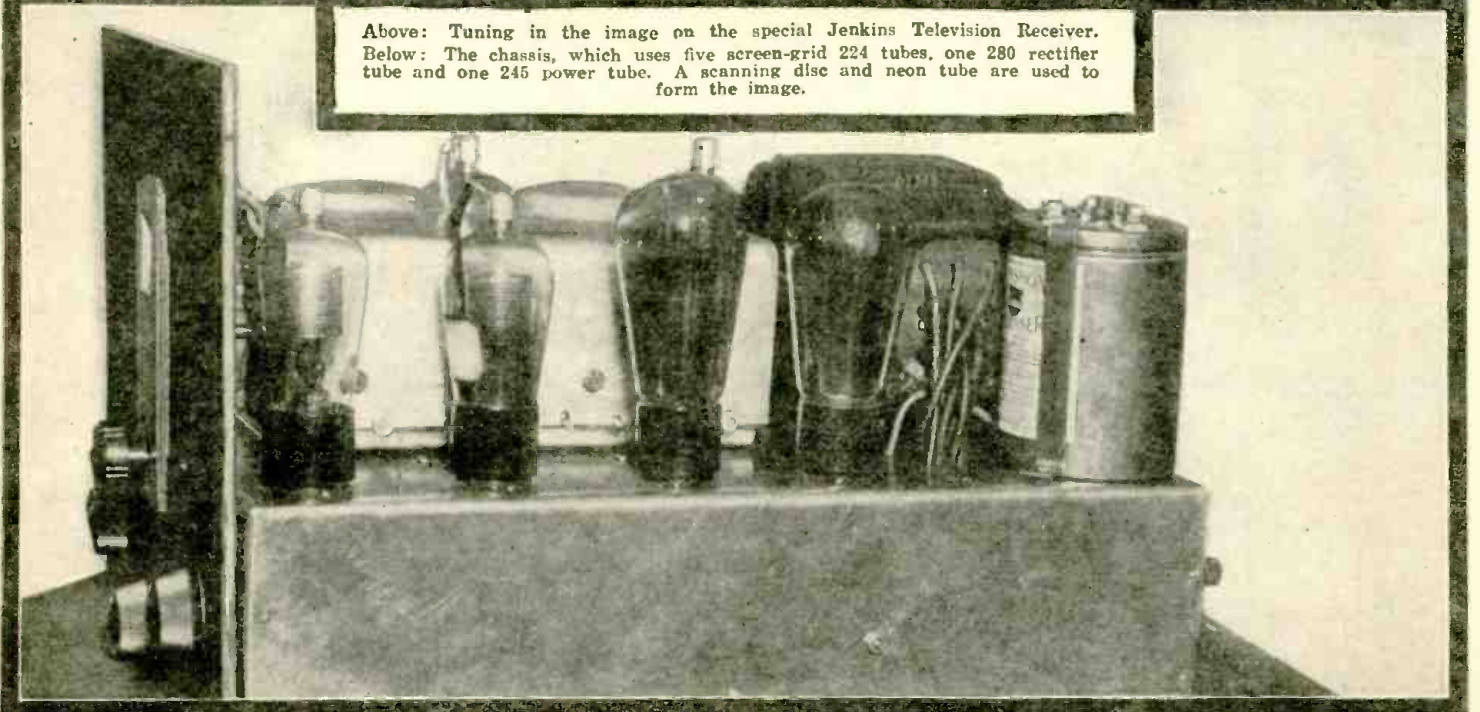

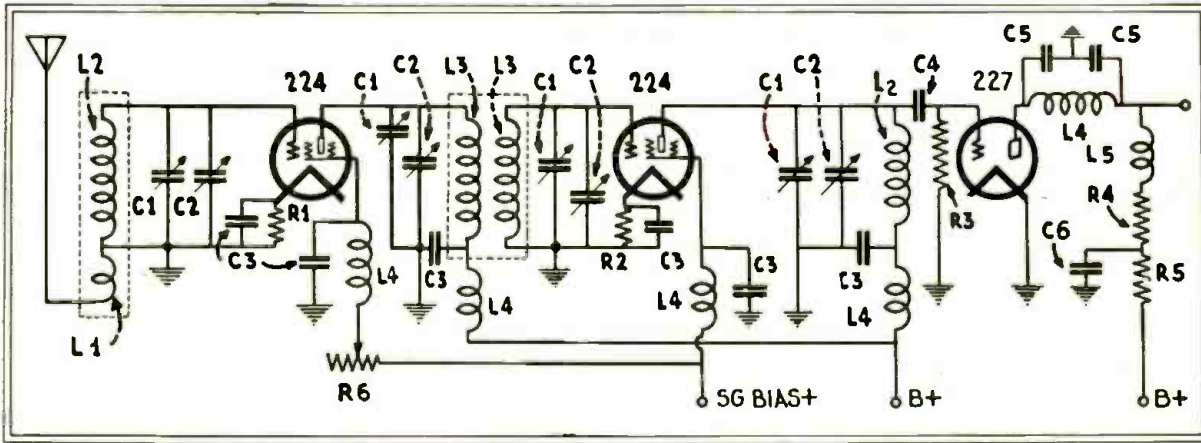

Radiovisior receiver with band-pass filter, Fig. 2: L1, 24 turns No. 32 DCC, 1 in. diameter; L2, 48 turns No. 32 DCC, 1 in. diameter; L3, 48 turns No. 32 DCC, 1 in. diameter (ends together); L4, R. F. choke; L5, 20-100 mh. choke; C1, .00015-mf. gang condenser (shielded); C2, trimmer condenser (shielded); C3, .01-mf. R.F. by-pass condenser; C4, .0001-mf. grid condenser; C5, .001-mf. by-pass condenser; C6, 1-mf.; R1, 500 ohms; R2, 500 ohms; R3, 2 meg.; R4, 30,000 ohms; R5, 20,000 ohms; R6, 0-200,000 variable resistor.

is expected from the speaker, the low-voltage end of the output device should be grounded through a 2-mf. condenser.

In order to pass modulation frequencies of the order of 30,000 cycles through the output circuit, it is necessary to pass a band of frequencies 60 kilocycles wide through the R. F. circuits. This calls for some rigorous design work in the field of coupled circuits. In the R. F. circuit shown in Fig. 2, it will be noted, the first and second R. F. stages are coupled by means of the now familiar "band-pass" method. The coils are so wound that a sufficiently wide band is included over the entire tuning range. The antenna and detector input circuits are sufficiently damped to cover the required band without resorting to special measures.

Television Receiver Now Available

Commercial receivers of the required characteristics are now available to those who are not of an experimental turn of mind. One of these receivers, in conjunction with the Jenkins television receiver appears on the opposite page. The "Model 100" radiovisior at the right is a study in compactness and efficiency. Its main driving motor is of the Faraday-disc type familiar to physics students. In addition to this, a small synchronous motor of simplified design is employed to hold the disc in synchronism with that at the transmitting station. The Faraday, or "eddy-current," motor serves merely to maintain the disc in motion, supplying the friction and windage losses. This model is obtainable both in complete form and in a construction kit.

How Disc Is Adjusted

The simplicity of its operation may be judged from the following operating instructions.

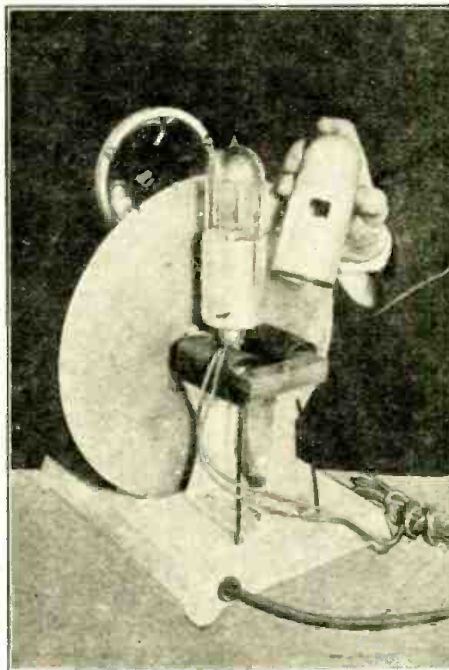

The Jenkins Model 100 Radiovisior—the neon tube, with its shield mask, adjustable to either 48-hole spiral of the 12-inch disc. The two "motor coils" are shown.

After tuning in the desired signal to the maximum intensity the procedure is as follows:

- (1) Turn on motor.

- (2) Turn motor rheostat up, so that the disc passes through and beyond synchronous speed.
- (3) Retard speed slightly by turning rheostat to left.
- (4) Reduce speed still further, by braking with thumb and finger on motor shaft, until picture appears.
- (5) If the picture progresses to the right, the motor speed is too great; and the rheostat should be turned slightly to the left. If the travel is to the left, either the braking was too clumsily done or the motor speed is too slow to overcome the frictional load.
- (6) After synchronization has been attained the motor may "hunt" slightly. This "rocking" motion will die down of its own accord; but the result may be hastened by braking the motion slightly with the finger on the drive shaft each time the picture swings to the right.

Framing the picture in either the horizontal or the vertical "sense," is accomplished by means of a hood covering the Neon tube. In the event that reception of 24- or 60-line pictures is desired, extra discs and rotors for the synchronizing motor are available at slight cost.

Two kinds of entertainment are provided for those interested in the television reception. Transmission of motion-picture films and of direct-pick-up subjects is made on regular schedule from the two Jenkins stations and from an increasing number of others. For those employing receivers incapable of finer delineation, silhouette movies in black-

(Continued on page 163)

15 to 30,000 cycle radiovisior amplifier—Fig. 1.

- C1—2-mf.
- C2—1-mf.
- R1—.25 meg.
- R2—.05 meg.
- R3—1,000 ohms
- R4—2,000 ohms variable.
- R5—2,500 ohms variable.

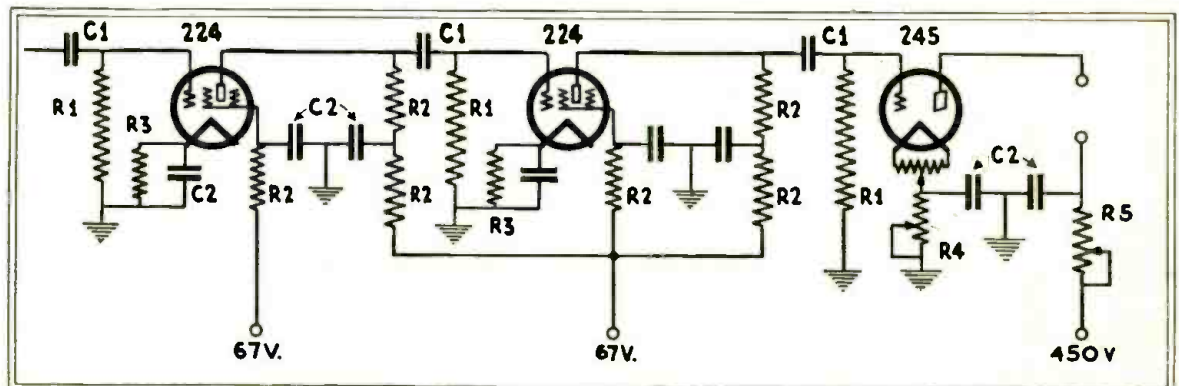

“MY FAVORITE” SHORT

Push-pull in both radio frequency and detector stages marks this outstanding short-wave receiver described in detail by Mr. Schnell. Mr. Schnell, one of the leading experts in the realm of short-wave radio, told the editors that he had been experimenting for a long time with this receiving set before he decided to release it for publication. This particularly efficient receiver should make many friends with our readers. Data for winding the coils are given.

THE design and construction of a good short-wave receiver depend a great deal upon the purpose for which it is to be used. No hard and fast rules can be set down unless the short-wave receiver is to be used for a limited purpose (like those used in commercial radio on fixed frequencies). Receivers, such as are used by the radio amateur and the short-wave broadcast enthusiast, are subject to many different requirements, and, accordingly, provisions have to be made to carry out each and every purpose with a certain degree of satisfaction. While some needs will be better satisfied than some others, a happy medium must be struck to bring about the greatest degree of all-around satisfaction.

Desirable to Spread Out Band

Particularly in amateur radio, where the frequency bands are limited, it is desirable to spread out the bands, for better control of secondary tuning. The several ways to do this provide for every practical case that may arise. If the secondary tuning condenser is of the order of 125- to 150-mmf. capacity, without question there should be a vernier tuning control, if the maximum results are to be obtained. One method of extremely fine tuning is to use a slow vernier dial; but, for the desired result, it would have to be geared to a ratio in the neighborhood of at least 100 to 1—a mechanical problem, backlash and all other things considered. Another is to use a very small vernier condenser shunted across the regular tuning condenser; and even this should be controlled by a vernier dial of the National “A,” “B” or similar types. The latter method probably is the most satisfactory in use at present. Some short-wave receivers are made with a secondary tuning capacity of such value as to permit spreading each amateur band over a wide portion of the tuning dial. This type of short-wave receiver, in order to cover other wavelengths, would require a large number of inductances—far too many for general use. Instruments are now available whereby a reasonably satisfactory degree of coarse tuning is obtained with a high capacity, while the fine tuning is done with a vernier plate which is built right into this type of condenser.



F. H. SCHNELL

Mr. Schnell has been interested in radio since 1909; since that time has owned and operated a successful amateur station and actively participated in amateur radio. Entered Naval Radio Service at Great Lakes, May, 1917. October, 1917, to August, 1918. Transatlantic Receiving Station, Belmar, N. J. December, 1918, to March, 1919, chief radio operator on the U.S.S. George Washington, when that ship carried President Wilson to Europe and back. March, 1919, to October, 1920, with Thordarson Electric Manufacturing Co. September, 1919, met with K. B. Warner, C. D. Tuska and R. H. G. Mathews at Washington, D. C., and prepared a resolution which removed the war-time ban on amateur radio—the ban was removed October 1, 1919. Became traffic manager of the American Radio Relay League. October, 1920; remained until April, 1926. March, 1925, to November, 1925, at the request of the Navy Department, conducted long range, high frequency communication tests during the cruise of the U. S. Fleet to Australia and the South Seas. Was promoted to the rank of Lieutenant-Commander for the work. Established first two-way amateur radio communication across the Atlantic from his station, 1MO-1XW, Hartford, Conn., communicating with Leon Deloy, F8AB, Nice, France. Since that time has communicated with every country on the face of the globe. April, 1926, to May, 1929, experimental radio laboratory of the Burgess Battery Company, Madison, Wisconsin. At present, Chief of Staff, Radio and Television Institute, Chicago, Ill. At present Mr. Schnell operates amateur station W9UZ.

For all-around tuning, and for something to cover the entire range of frequencies between 3,000 and 16,000 kilocycles, the new Aero unit (described in the June-July issue of *SHORT WAVE CRAFT*) meets every reasonable demand.

Regeneration Control

One other vitally important feature, in any type of short-wave receiver, is the regeneration control system. There are some five or six different combinations possible, whether the system be

capacity control or resistance control. Satisfactory regeneration control, regardless of the method used, depends largely upon the type of tube, the grid condenser and grid leak, and the tickler arrangement. A careful selection of the various parts used means just so much less trouble when it comes to putting the receiver into operation. Tubes, grid condensers and grid leaks are fairly uniform; of these, the grid leak still seems to be least so. Smooth regeneration control is one of the best indications of good receiver construction; and it is the one thing which will tend to overcome the difference between hearing a weak phone station and not hearing or, at least, not understanding what is being said.

After all is said and done, a good short-wave receiver for amateur purposes is one which is simple in construction, and gives ease of control, smooth regeneration, sensitivity and fairly good appearance. All these things can be incorporated into a short-wave receiver if time and care are given.

Arrangement of Apparatus

The front panel of such a receiver is shown in Fig. 1. The dial on the extreme left is the radio-frequency control; the small dial controls the vernier condenser across the secondary tuning condenser which is operated by the third dial from the left; and the fourth dial is for the regeneration control. Phone jacks, filament rheostat, filament voltmeter and on-off switch are shown on the right. The appearance suggests that there are too many dials, but such is not the case. For all practical tuning, the radio-frequency dial and the regeneration control dial are set at some desirable spot, in or near one of the amateur bands. When a station is heard (by tuning with the secondary condenser) it is brought to the desired point of resonance for best signal strength, by use of that condenser, which is of such capacity that this can be done without difficulty. In the event of interference, the radio-frequency dial is adjusted to a point where that circuit comes into resonance. Many times this results in reducing the interference, but not eliminating it; interference in this case is probably that coming from other stations and not local power leaks or

WAVE RECEIVER

By
F. H. SCHNELL*
Famous Short-wave Expert

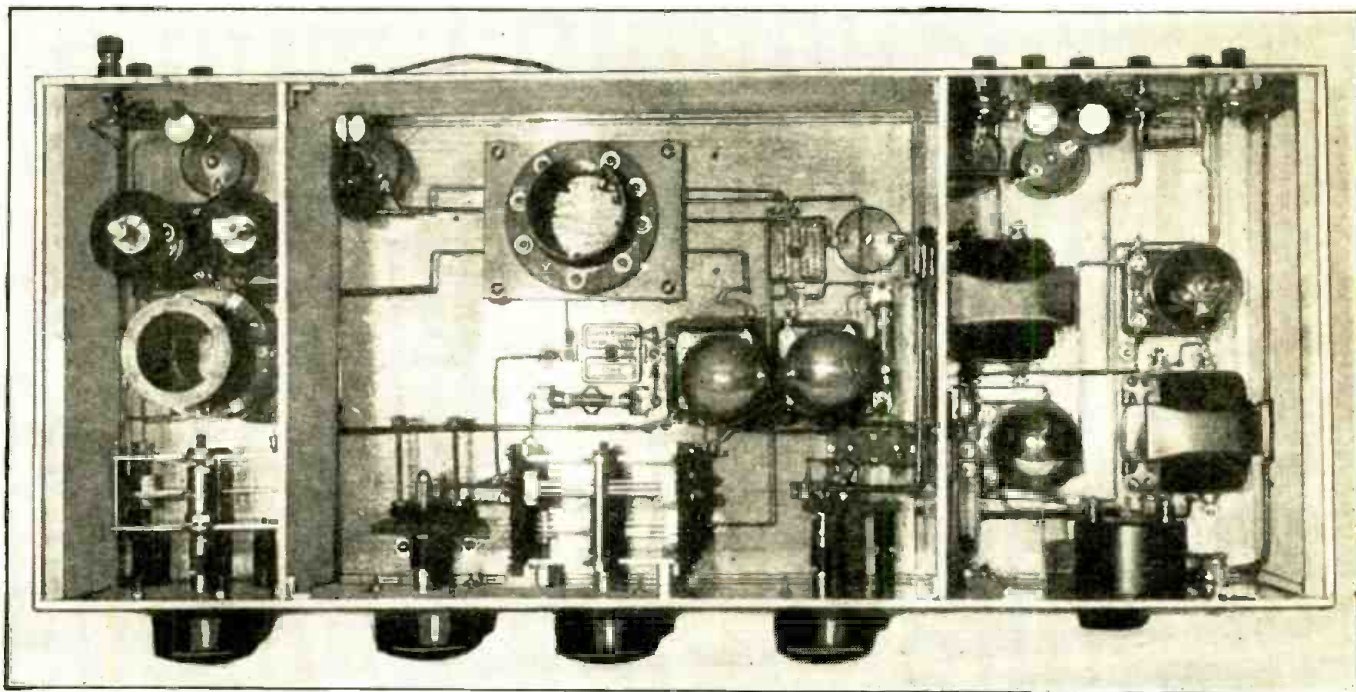

Fig. 2, herewith, shows view of interior of "My Favorite" short-wave receiver designed and constructed by Mr. Schnell after careful research. This receiver employs push-pull radio frequency stage, as well as a push-pull detector stage, which insure a very healthy signal being delivered to the audio stages.

static or other atmospheric disturbances, etc. When the radio-frequency circuit fails to reduce the interference to a level which permits copying the desired signal, the vernier control condenser is used; and usually this makes it possible to creep to a position between the interference and the point where the desired signal can be copied.

Of course, if the interfering signal is broad and smothers the desired signal, it just "goes by the board." In extreme cases, a sharply-tuned audio stage, such as the Aero "Hi-Peak," will reduce some of the worst forms of interference.

*Chief of Staff, Radio & Television Institute.

For phone reception or short-wave broadcast reception, the extremely smooth regeneration control permits maximum signal strength, without oscillation in the detectors.

Inside Assembly

Fig. 2 shows the inside assembly, looking down from the top. In the shielded compartment, at the left, is the radio-frequency stage. Chokes and by-pass condensers are mounted in this compartment, where they are used in the radio-frequency leads of this circuit. The middle compartment includes the two detectors, their inductances, the tuning and vernier condensers, the regeneration control, grid leaks and grid condensers.

The compartment on the right includes the two audio stages.

Fig. 3 shows a close-up of the radio-frequency stage in which the inductance is so mounted as to be at greatest distance from all shielding. The radio-frequency and the antenna coupling coils are wound on standard Silver-Marshall forms; and the socket is mounted on insulating posts of bakelite. The condenser is the single-plate Cardwell—shown just behind the panel, from which it is insulated.

In Fig. 4, the radio-frequency and antenna coils are visible at the left, and one of the secondaries to the right. The

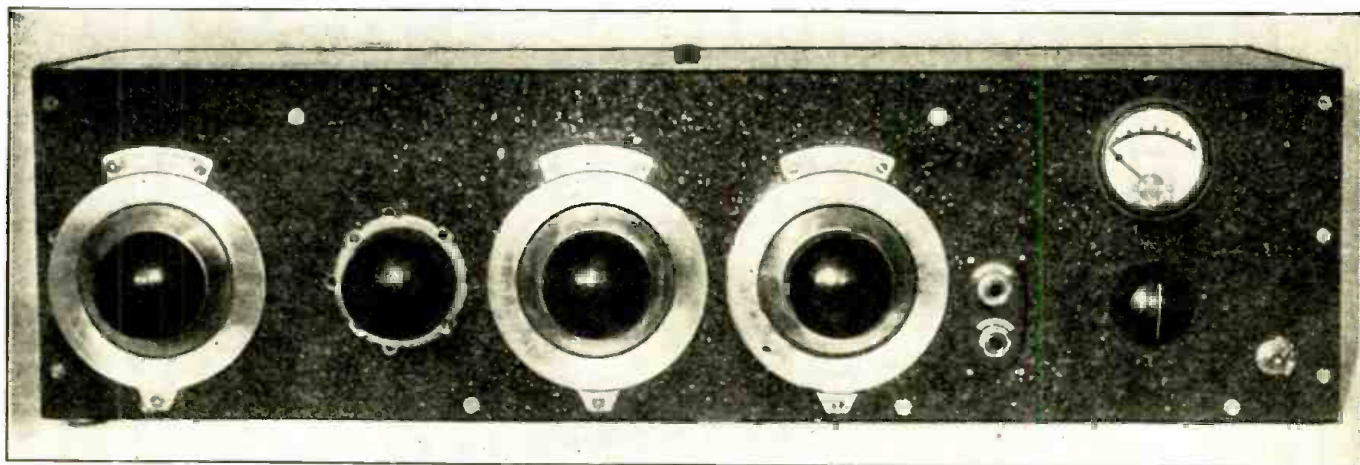
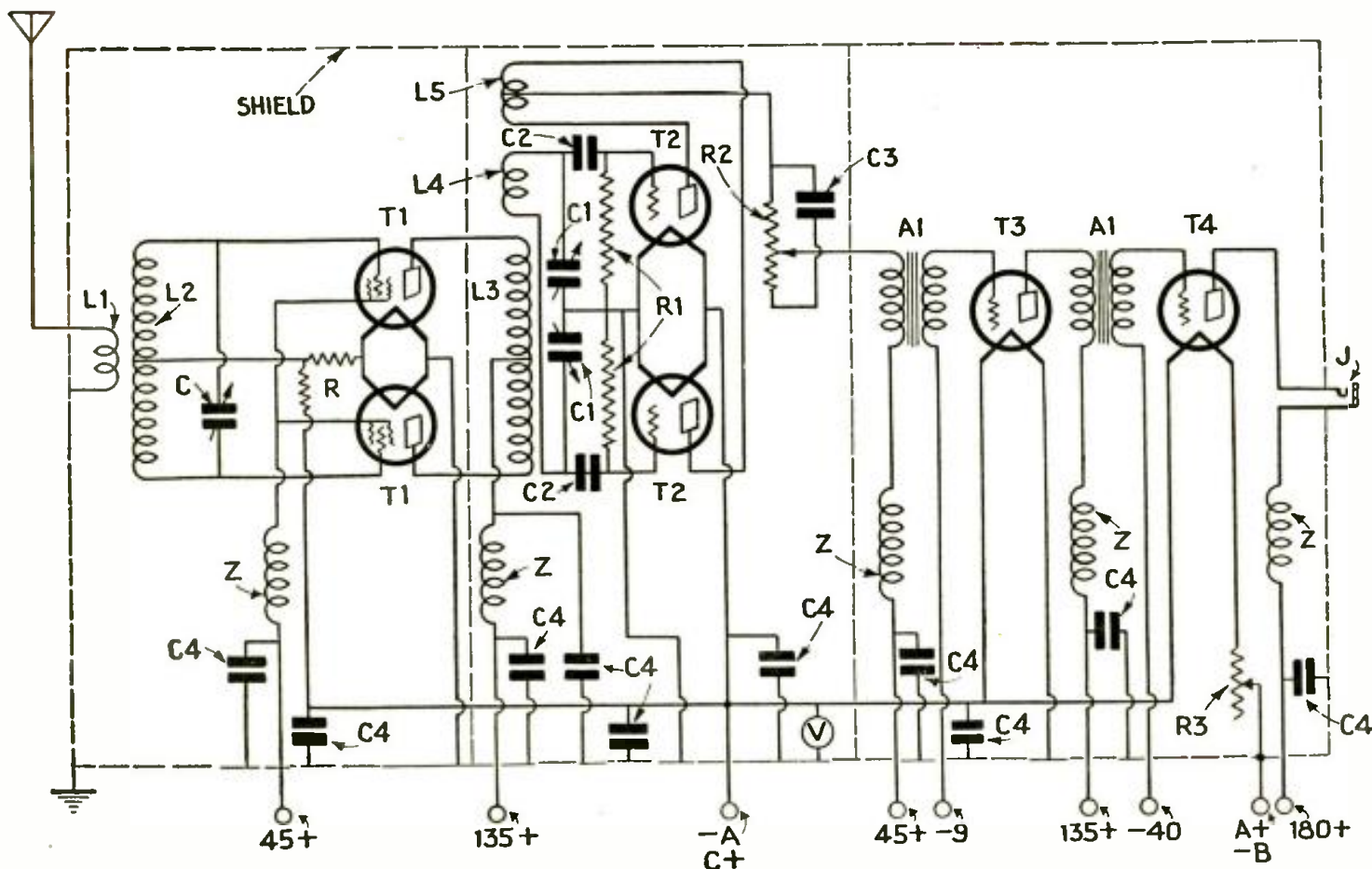

Fig. 1, above, shows front panel with dials, jacks, meter, rheostat and switches of Mr. Schnell's highly efficient short-wave receiver.



Complete wiring diagram for Mr. Schnell's exceptionally efficient and selective short-wave receiver, in which he employs push-pull action for the radio frequency as well as the detector stages. The audio section comprises two stages of transformer coupled amplification.

plate inductance coil (from the screen-grid tubes) is wound underneath the secondary coil and above these two windings is the tickler coil.

Fig. 5 illustrates a set of four coils: 15 to 18.7 meters; 19 to 24 meters; 35 to 44 meters and 72 to 90 meters. Their constants are given in the table. Other coils can be made to cover the other wavelengths or such of them as may be desired.

Fig. 6 shows the jack arrangement of eight connections; three for the plate inductance of the screen-grid tubes; two for the secondary and three for the tickler.

No Body Capacity

When the lid of the case is closed, there is not the slightest sign of body

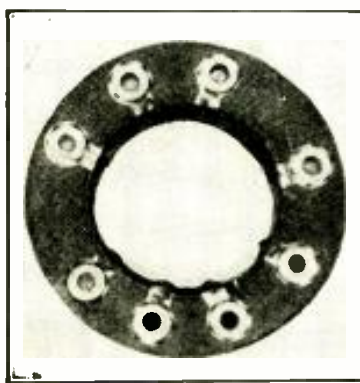

Fig. 6, above, shows the jack arrangement of eight connections, three for the plate inductance screen-grid tubes, two for the secondary, and three for the tickler.

capacity at any lead or any part of the receiver. The case is of 1/8-inch aluminum—top, bottom and sides—and provides quite satisfactory shielding. Space will not permit listing the stations heard on this receiver. For broadcast reception it is satisfactory, especially since it is designed to meet all requirements; though it was used particularly for amateur reception and communication.

A careful study of the circuit diagram reveals several different possible arrangements of the different parts; so that almost any sort of combination can be worked out to suit the particular re-

quirements of the constructor. The components used were as follows:

List of Parts

- L1, L2, L3, L4 and L5—see table;
- C, 50-mmf. variable condenser;
- C1, double (Cardwell) variable condenser, 50-mmf.;
- C2, grid condensers, .00015-mf.;
- C3, 0.5-mf. fixed by-pass condenser;
- C4, 0.25-mf.; by-pass condensers;
- Z, Aero choke coils.
- T1, DeForest 422 (screen-grid) tubes;
- T2, '01A detectors;
- T3, '12A first audio amplifier;
- T4, '71A output amplifier;
- J, Loud speaker or phone jack;
- A1, A2, Thordarson "R-300" audio transformers;
- R, 15-ohm resistor, tapped at 5 ohms;
- R1, 10-megohm grid leaks;
- R2, 50,000-ohm Frost potentiometer, regeneration control;

(Continued on page 160)

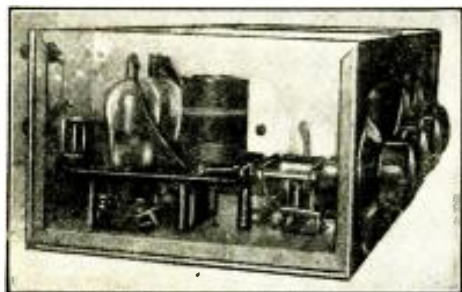

Fig. 3. View from the left-hand end of short-wave receiver with one side of shield box removed, showing push-pull radio frequency stage.

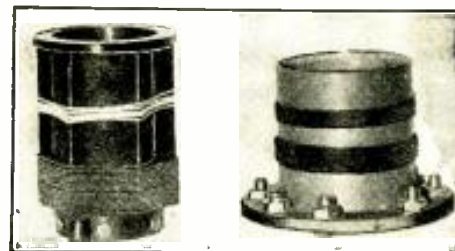

Fig. 4 shows the radio frequency and antenna coils at the left and one of the secondaries at the right.

Plant Growth Speeded Up

By Ultra-Short Waves

By DR. ALBERT NEUBURGER

THE processes occurring in the growth of plants are still far from being fully explained. We know that soil and climate play their parts—we know also that the rays coming from the sun are of the highest importance. In general, it has been assumed that the length and strength of the solar rays are the determining factors. But various facts contradict this assumption; for example, even in valleys with slight solar radiation, very quick maturity is often attained. Hitherto the sun's rays have been, incorrectly, considered as a whole. As a matter of fact, they comprise radiations of very different wavelengths.

Of this band there are apparent to our eyes only the rays which we term the solar spectrum, or the visible "seven primary colors"; but the true solar spectrum is more extensive. At the point where it seems to end in darkness for us, there lies, joining the violet, a further range of rays imperceptible to our eye, the *ultra-violet*, so much used in medicine. On the other side of the spectrum there is joined to the deepest red the similarly invisible *infra-red*, of whose existence we can readily convince ourselves. If we put a thermometer beyond the red, it rises.

But the radiation extends still further, beyond the infra-red. Here there is a wide range of rays which only in recent times have been given rather detailed investigation in various directions.

This is the field of the short-wave rays, which exhibit many peculiarities.

These also invisible rays have, beyond everything else, remarkable biological effects. The Berlin physicist, Fritz Hildebrand, experimented with such rays, of wavelengths lying between 1/25th of an inch and 12 inches, on sprouted plant seeds. He then found that, by extremely short irradiation (exposure to rays) of only 15 seconds, an increased activity of the cell material was produced, which expressed itself above all in an accelerated growth, a growth bordering on the marvelous.

The experiments were performed with various plants, chiefly edible vegetables, and mainly with the sprouted seeds of beans, kohlrabi, cabbage, pumpkins, tomatoes, radishes, sunflowers, etc. Then the irradiated seeds were sowed in poor ground, in the notoriously thin sandy soil of Brandenburg. According to his statements, radishes which had not been irradiated showed no development after four weeks; but the irradiated plants, with the same cultivation, were already edible after two weeks. At the same time it was remarkable that the tops of the radishes which had not been irradiated had reached almost the same size as those irradiated. The other results in general correspond to those just described.

While sunflowers not irradiated had not yet attained half their growth, those from irradiated seeds were completely grown and mature in the course of six

weeks. Likewise, pumpkins could be called "ripe" after the same length of time. They had attained a diameter of about 16 inches. Tomatoes require special cultivation.

From his experiences Hildebrand concludes that the process of maturing can, in the case of many plants, be reduced to half the usual time by the irradiation of the seeds.

Whether this will be true of all plants, more especially our vegetables, cannot as yet be said today. Each species of plant is an individual living type which, with regard to its cellular activity, acts differently from other species. Therefore it would seem wrong to assume that by means of a short irradiation, with any wavelength between 12 inches and 1/25th of an inch, the same results can always be obtained.

Rather, we must determine how each individual wavelength affects each species of plant. In this way we can determine which kind of radiation is the most favorable and which the least so.

In view of the numerous species of plants available for this work, as well as the fact that the wavelengths of the band of rays mentioned can be varied by millimeters, and even fractions of a millimeter (1/25-inch), an extensive and promising program of experimentation is possible. The results so far obtained must be regarded as merely a beginning which awakens great hopes. Starting from it, there is still much research work to be done.



Sunflowers: left, irradiated; right, not irradiated. Irradiated 15 seconds.

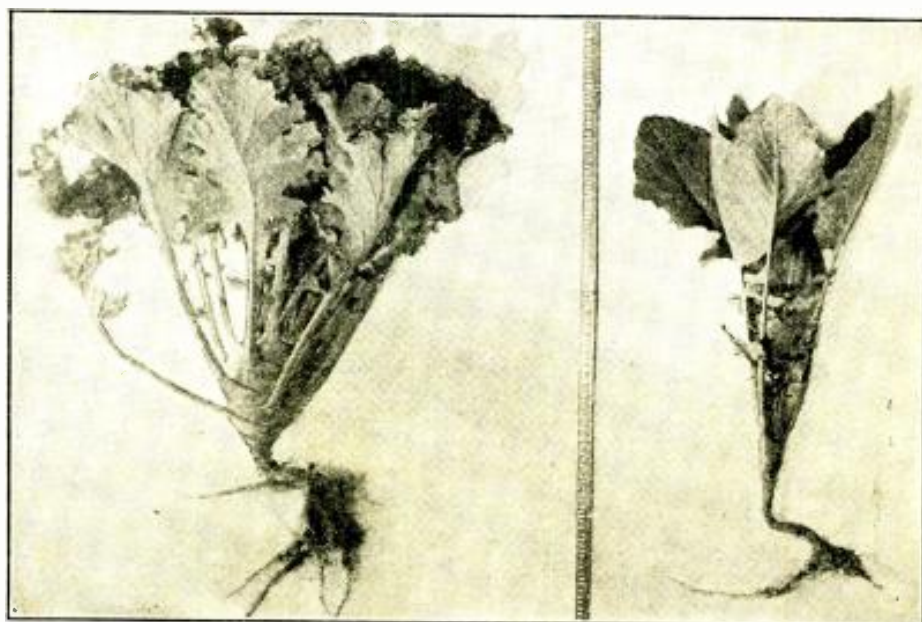

Kohlrabi: Irradiated and not irradiated. Set out June 23, 1929; photographed September 24, 1929. Irradiated 15 seconds.

Interesting Technical Details Aerials Used in Between Schenectady,

This article was prepared through the courtesy of the General Electric Company, who gave the writer permission to visit the short wave transmitting and receiving stations at Schenectady, from which point the radio communication was carried on to and from Australia and New Zealand.

By H. WINFIELD

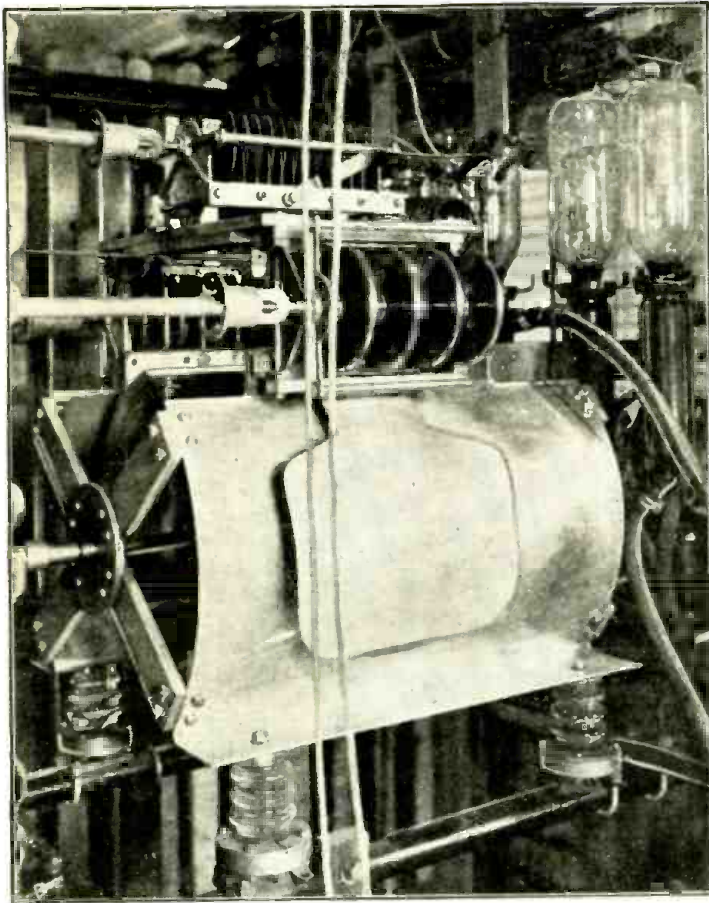

Interesting close-up view of one of the short-wave transmitting condensers at Schenectady. Note the two high power, water-cooled tubes at the right of the picture.

Fig. 2 below shows relative position of the three short-wave receiving aerials used in the Byrd broadcast from Australia.

Introduction

MANY listeners, who have grown accustomed to international relays of programs from Germany, England and Holland, enjoyed a new experience recently when they heard conversations carried on between Schenectady, New York; Dunedin, New Zealand; Wellington, New Zealand, and Sydney, Australia, in the longest talking circuit ever broadcast.

The occasion was the welcome of Rear Admiral Richard E. Byrd by Adolph S. Ochs, publisher of the *New York Times*. The epochal broadcast was initiated by the General Electric Company as a climax to over a year of special fortnightly programs transmitted to the Byrd Expedition. Mr. Ochs, speaking in the receiver laboratory eight miles from the city of Schenectady, was heard in Dunedin direct, through W2NAF, the 31.48-meter transmitter of WGY. The distance covered was 9,320 miles. Admiral Byrd and Russell Owen, correspondent of the Expedition, spoke in the studio of 4YA at Dunedin. The voice impulses were then carried by about 485 miles of land wires and sixteen miles of submarine cable to Wellington, New Zealand. At Wellington, Station 2YA, a 5,000-watt transmitter operating on 420 meters, directed the signals to Sydney, Australia, 1,200 miles away and in an opposite direction from Schenectady. At Sydney, 2ME (owned and operated by the Amalgamated Wireless Australasia, Limited) rebroadcast the output of 2YA and transmitted the signal 9,930 miles to Schenectady on a wavelength of 28.5 meters. The words of Admiral Byrd traveled 11,630 miles.

2YA is the strongest station in New Zealand and the management very naturally desired to get both sides of the conversation for the station listeners in that country. Instead of using the station for the output of the Dunedin wire only, 2YA picked up W2NAF and transmitted the combined signals, or both sides of the conversation. This combined signal was passed on to 2ME at Sydney and sent to Schenectady. W2NAF, therefore, got its broadcast back again after a journey twice across the Pacific and the United States; and the returned signal, received an eighth of a second after it left the Schenectady transmitter, furnished an echo which caused considerable distortion.

Forty stations in this country broadcast the Byrd program. WGY's short-wave transmitter, W2NAD, on 19.56 meters, using a directional antenna to Europe, put the program into Germany.

A special selective receiving system was utilized at the receiver laboratory near Schenectady. Three receivers, each with its antenna system, and each system widely separated from any other, were tuned to the signal of 2ME. If the signal faded from one, it was stronger on one of the others; and the strongest of three signals was automatically selected. W2NAF used a special, directional, horizontal half-wave antenna for the transmission to Australia.

Strongest Signal of Three Automatically Selected

IN the diagram (Fig. 1) we see as a typical example, the three received signals from the three respective antennae; at the bottom of the diagram is indicated the final resultant signal which was selected by a special vacuum tube circuit. In other words, it has been found that, if three antennas are set up at a distance of about 1,000 feet apart, the aerials being placed either in a row one behind the other, or abreast of each other, or again in triangular fashion (as shown in one of the accompanying drawings of the WGY receiving station) then at any given instant the received signal will be strongest in some one of the three antennas.

This trick of selecting the strongest received signal from any one of a series of antennae, automatically and continuously, represents one of the finest accomplishments of the radio research laboratory. In other words, where a

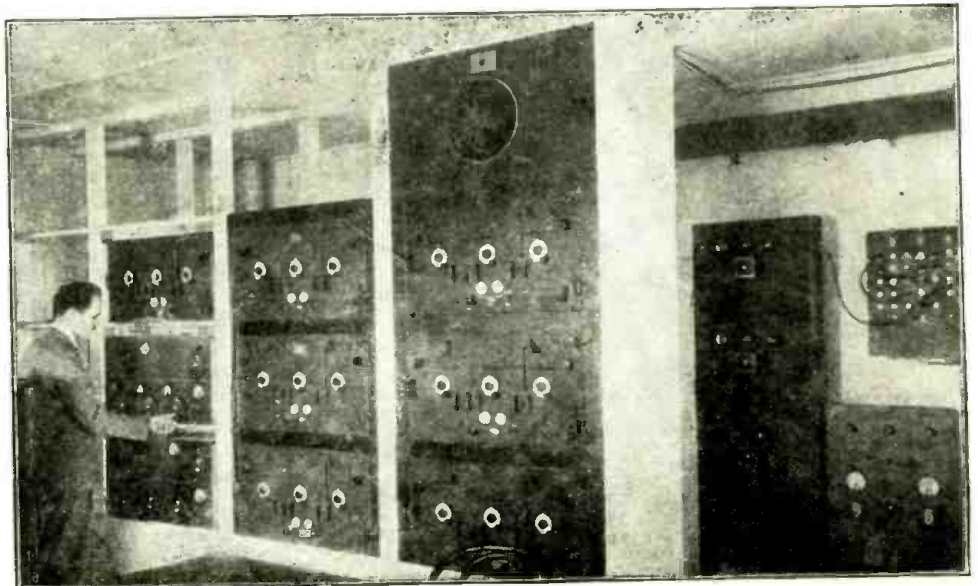

Short-wave receiving apparatus at North Schenectady (Sacandaga) where Admiral Byrd's voice was picked up.

of the Short Wave

Byrd Broadcast

New Zealand and Australia

The Byrd radio talk bridged a distance of nearly 10,000 miles, one way. This was the longest talking circuit ever broadcast. The author explains in the present article how a practically constant strength of received signal is maintained, irrespective of fading.

SECOR

long-distance, short-wave signal might be received in a fluctuating manner by the ordinary short-wave receiving instrument connected to a single antenna, the perfected receiving arrangement in use at WGY results in impressing a practically constant strength of signal upon the audio amplifier at practically all times, except when unusually severe static or other atmospheric disturbances render this result impossible.

Fig. 2 shows the general arrangement of the three short-wave receiving an-

One corner of the short-wave transmitting station at Schenectady, from which point the voices of Mr. Ochs and others were propagated 9,300 miles to Dunedin, New Zealand.



tennas at the Glenville, N. Y., or Sacandaga, receiving station, where Admiral Byrd's voice was picked up from half-way around the globe, in Australia. The three aerials could be placed in a line with 1,000 feet separation between them, the General Electric Company's en-

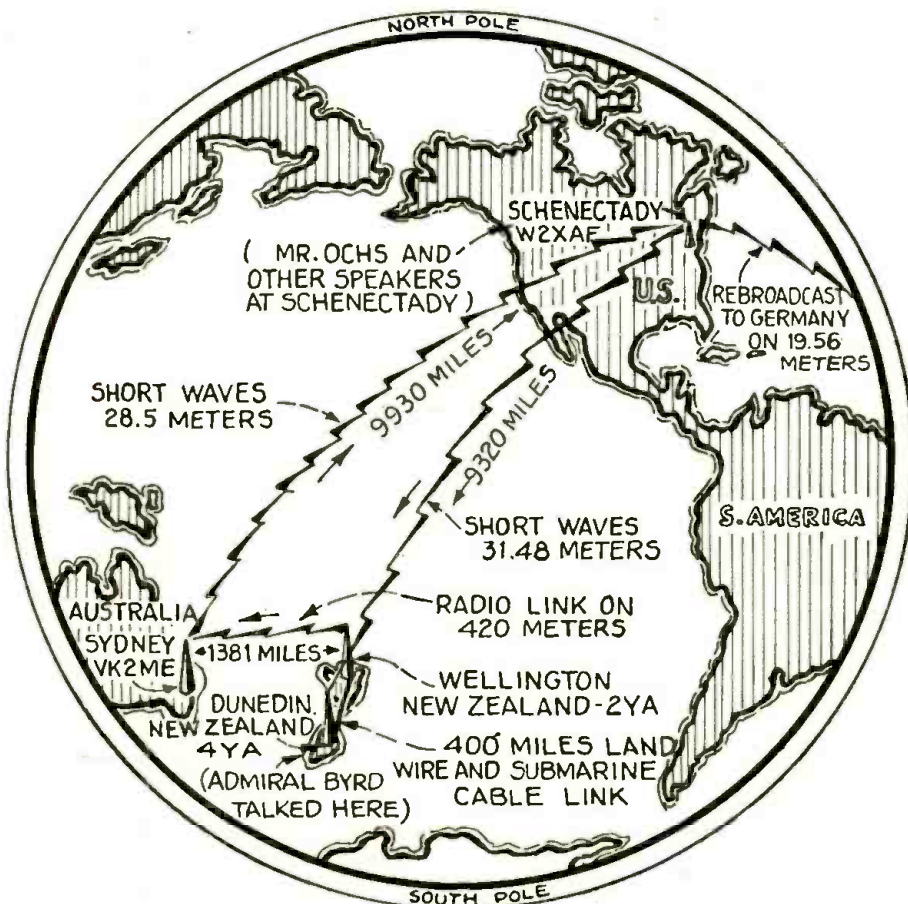

This map shows the wave lengths used and also the distances covered in the famous Byrd broadcast between Schenectady, New Zealand and Australia.

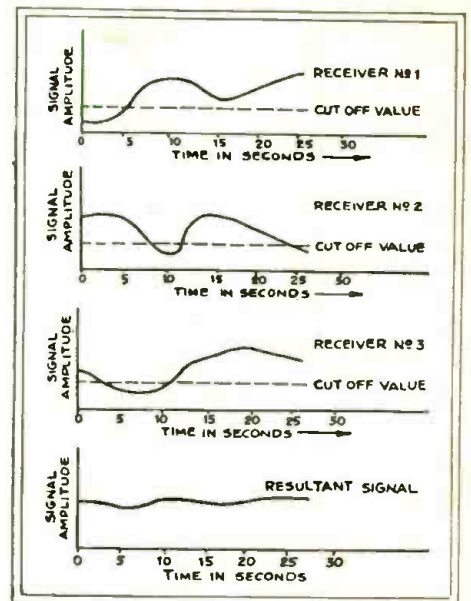
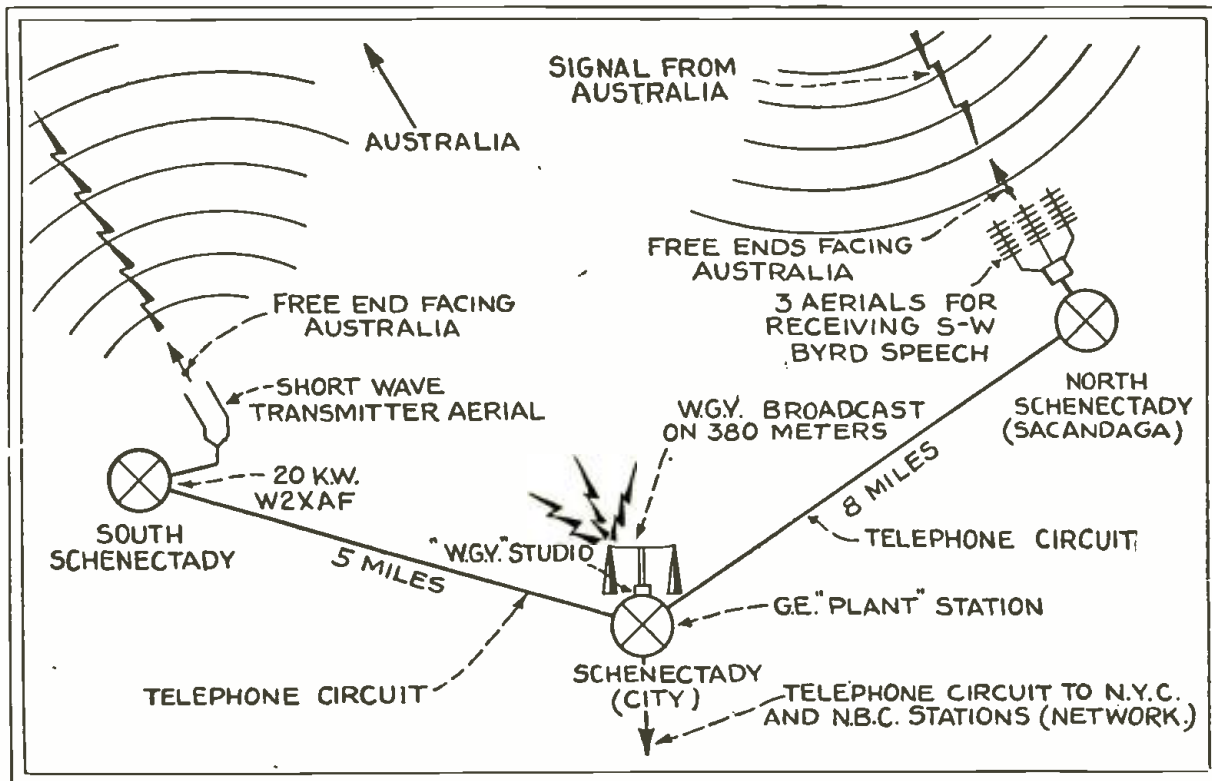

Fig. 1 above, shows how the three independent receiving aerials, spaced about 1,000 feet apart, each pick up a different strength of short wave signal. An automatic bias arrangement constantly selects the strongest signal of the three, resulting in a practically constant strength signal being heard, as shown by the lower graphic curve.

gineers told the writer on a recent visit to Schenectady; or the three antennas could also be placed side by side with 1,000 feet separation between them. However, the short-wave experts at Schenectady believe that the greatest freedom from fading is obtained by the triangular arrangement of the three antennas shown in Fig. 2. Note that the aerials point in the direction of Australia.



This simplified map of the short-wave transmitting and receiving stations at Schenectady shows the three main centers of activity; the receiving aerials which picked up Admiral Byrd's voice nearly 10,000 miles away in Dunedin, New Zealand, are located at Sacandaga, eight miles from the WG.Y. station at Schenectady. The voices of Mr. Ochs and others which greeted Admiral Byrd were radiated from the 20-kw transmitter W2XAF at South Schenectady. The conversations were broadcast by WG.Y. on 380 meters and also over the N.B.C. network, via telephone circuit, to New York City.

Through the courtesy of Mr. William T. Meenam and Mr. Maurice Prescott of the General Electric radio staff, we are enabled to give the interesting details of the 10,000-mile, short-wave receiving antennas at the Sacandaga re-

ceptions have been used. At the free end of the feeder there is a 410-ohm terminal resistor which is shunted across the transmission lines; in the antennas used at Sacandaga for the Byrd reception and other experiments, it is not grounded. Note that the antenna conductors proper, AA, are capacitively coupled through small condenser to the central feed wires. The whole antenna (that is, one unit) measures 312 feet in length and 85 feet in width.

tographs; each stage of radio frequency amplification employs a shield grid tube and the condenser of each stage is tuned separately, not by the gang method. After the incoming signals from the antennas have been strongly amplified by the four stages of R. F., all three then pass into the detector; special bias control then selects the strongest signal (or rather forms the resultant of the three signals) and passes on a single signal current of practically uniform strength to the audio amplifier.

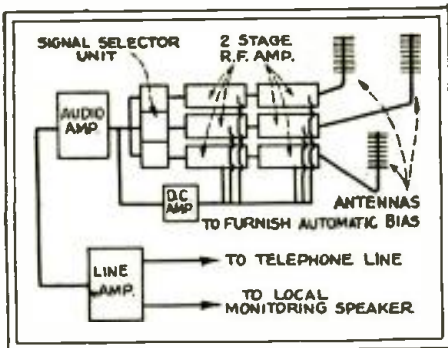

Fig. 5. This diagram shows how the three short-wave receiving antennas at Sacandaga (North Schenectady) feed their respective signal currents into three independent short-wave amplifiers. Signals are detected and then passed into a special vacuum tube signal selector, which preserves a practically uniform strength of signal, and passes this signal on through an audio-amplifier and then to the line amplifier and monitor.

The receiving instruments are connected to the antennas through a four-wire transmission system which can be 1,000 feet long or more; since this transmission or connecting wire between the antennas proper and the receiving instruments has no effect on the wave length of the antenna itself. This four-wire transmission link in the antenna system is carried along on small poles at a height of four to eight feet above the ground, the height not being critical. The wires comprising the transmission link in the antenna system are supported by insulators, mounted on small cross-arms secured to the poles. Fig. 4 shows the connections of the down-leads from the antennas to the transmission line leading to the receiving station building.

This amplifier may comprise any de-
(Continued on page 167)

ceiving station, illustrated in Fig. 3. Each receiving antenna, of which there are three as shown in Fig. 2, is supported at a height of 60 feet above the ground on a series of cedar poles. The antenna conductors proper are supported by insulators, as clearly shown in the diagram, and the wavelength of the whole antenna unit of this type is determined by the length of the conductors at AA. If AA is 30 feet long, then the antenna system will give good results over a band extending from fifteen to thirty-five meters. The number of antenna conductors at AA does not affect the wave length; usually thirty-seven sec-

The Signal Selector

The arrangement and connection scheme of the various radio-frequency amplifiers, together with the newly devised vacuum-tube selector system, as well as the audio amplifier and the line circuit-amplifier, are shown in Fig. 5. The three short-wave receiving antennas are shown at the right of the diagram, and as will be seen, each feeds into four stages of radio frequency amplification. The appearance of these amplifiers is shown in one of the accompanying pho-

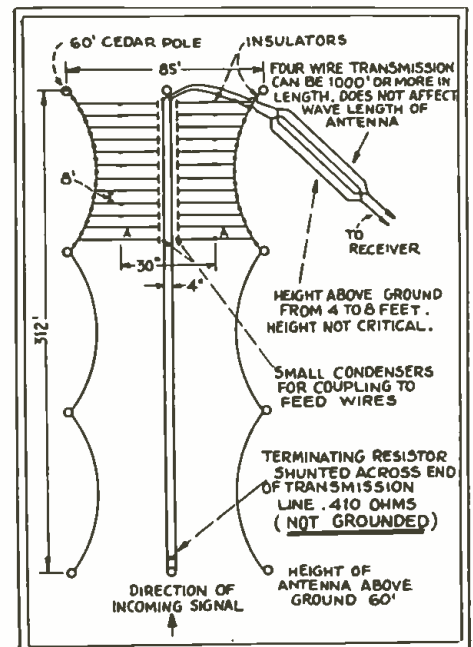
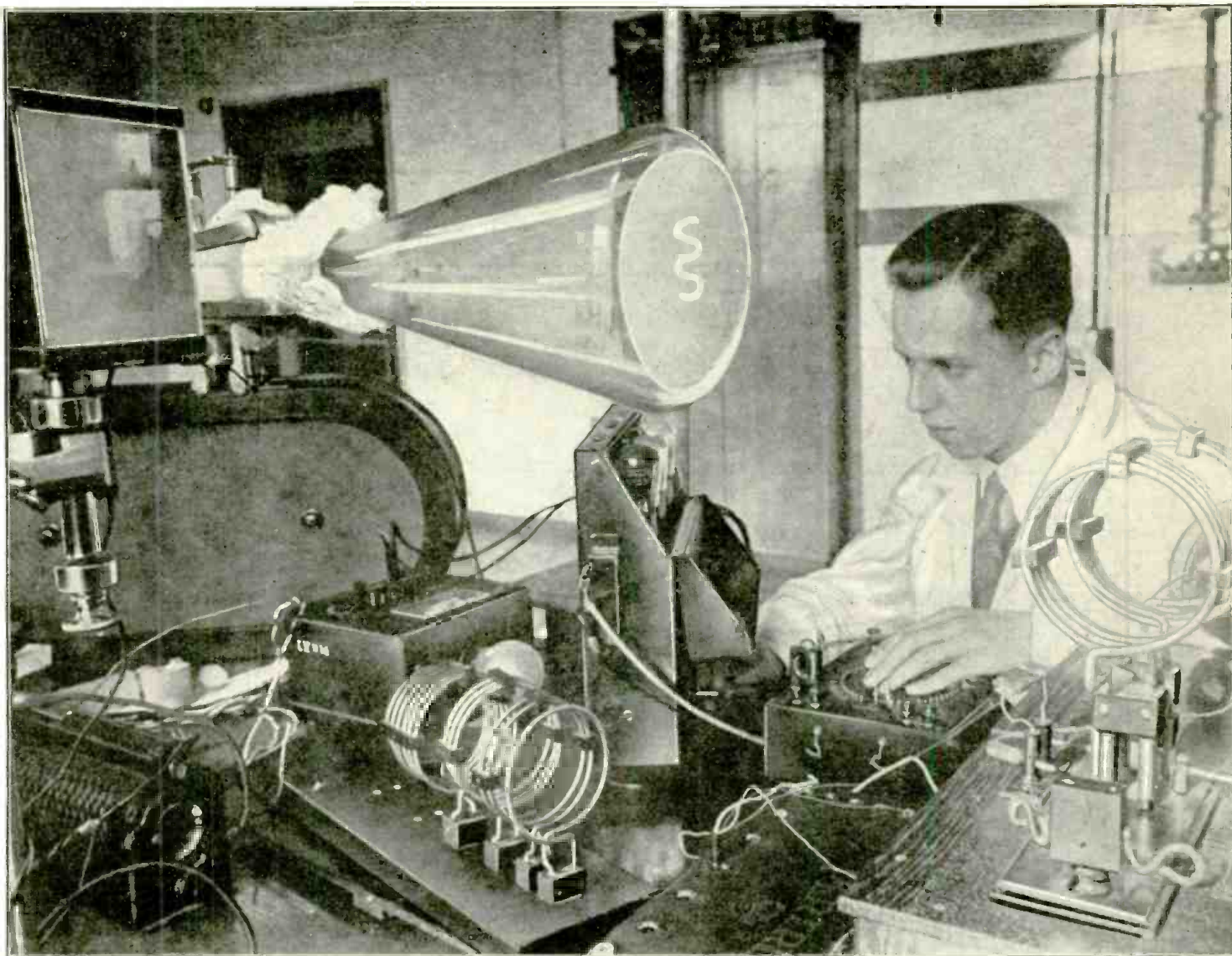

Fig. 3. Here we have all the important dimensions of one of the short wave receiving aerials used at North Schenectady in picking up Admiral Byrd's talk from New Zealand.



An intimate glimpse into one of the short-wave laboratories of the Heinrich Hertz Radio Institute, Berlin, Germany. One of the students is observed making short-wave measurements with the aid of a cathode ray oscillograph.

How Cathode Ray Records High Frequency Oscillations

The instrument illustrated on our front cover.

FOR making visual observations or photographic records of rapid changes in the current or voltage in high frequency circuits, the common oscillograph, with its moving mechanical members, is

quite useless. The ordinary oscillograph used in engineering laboratories is suitable for frequencies up to about 10,000 cycles per second, but when we come to frequencies of 100,000 per second, it is another story. The cathode ray oscillograph is based on the principle that when the cathode electrode is charged at a high voltage, a pencil of cathode rays is projected inside the evacuated tube and will manifest its travels on a special screen in the end of the tube.

The cathode ray, which can move at practically any frequency, as it has no inertia, is caused to move about and depict its various patterns on the screen (or photographic film) at the end of the tube, by virtue of electric charges caused to act on the cathode ray through the medium of small electrodes placed about the path of the ray, as shown in

(Continued on page 174)

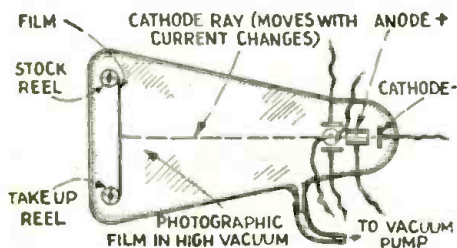

In making photographic records showing the oscillations taking place in high frequency and other circuits, the photo film and its reel mechanism have been placed inside the high vacuum tube.

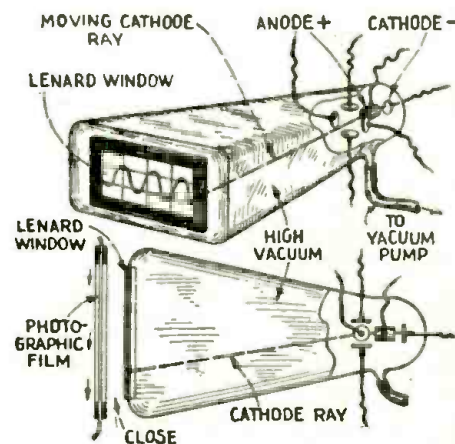

The newest method of making a photographic record of the oscillations in a high frequency circuit by means of a cathode ray tube, plus a Lenard window.

Use of Aircraft Radiophone Spreads



Important roles played by Short Waves in directing modern aircraft. Planes are being rapidly fitted with radiophone and code transmitters and receivers. Pilot "listens in" on long and short waves simultaneously.

Above: Pilot of plane wearing the latest style in radio headgear — a radio helmet combining small receivers for each ear and an adjustable microphone. The microphone may be slid back and forth to adjust it for each person, and when through talking, it is swung upward out of the way. — Photo courtesy Western Electric Co.

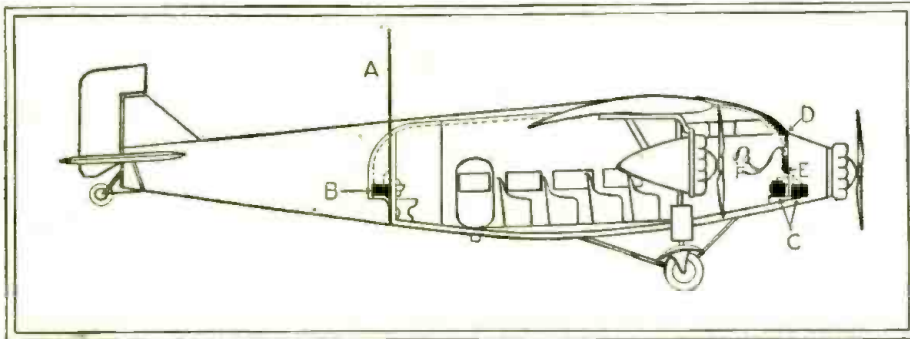

Left: Arrangement of the Western Electric Company radio transmitter and receiver on a large passenger-carrying airplane. The receiving antenna comprising a length of wire supported on a streamlined strut at A; B the radio receiving set; C indicates dynamotor and battery; D position of remote tuning control dials at pilot's seat; E remote volume control, while F indicates the headphones.

ON a chilly, rainy day a group of newspaper men stood in the hangar at Hadley Field, New Jersey. Outside in the murk a mechanic warmed up the motor of a cabin monoplane. To the newspapermen the outlook was not too pleasant. The morning paper representatives had been routed out of bed three hours ahead of their usual rising time. The men from the evening papers were anxious to hurry in order to make the early editions and get back to their offices out of the rain. But the Western Electric Company and the Bell Telephone Laboratories had promised something new, and that is the sort of thing that makes newspapers.

Two men were to go up in each flight of the plane and numbers were drawn to assign the flights. At length the first two men were called and the plane took off. For twenty minutes it soared around the cloudy New Jersey sky and then, landing, taxied slowly to the hangar. As the door of the cabin opened two newspapermen—obviously astonished—bolted out and rushed to the telephone booths. Another front page story had broken.

To engineers of the Bell System there was nothing particularly novel about the event. As early as 1918 they were experimenting in

this field. During the war airplane radio apparatus designed by them was used in government planes and experimentation has

The photo at right shows interior view of a radio dispatching station for aircraft routes, the operator sitting in front of one of the printer telegraph machines utilized in transmitting weather reports. Pilot of a passenger plane is seen standing at right, inspecting a weather map. Passenger-carrying airplanes of the transcontinental type and others used for carrying a number of passengers over long distances, are rapidly being fitted with radio transmitting and receiving equipment, which enables the pilot to receive the latest weather reports at all times. This is very important for safe flying, especially at certain seasons, when storms develop suddenly in the path of an onrushing plane.



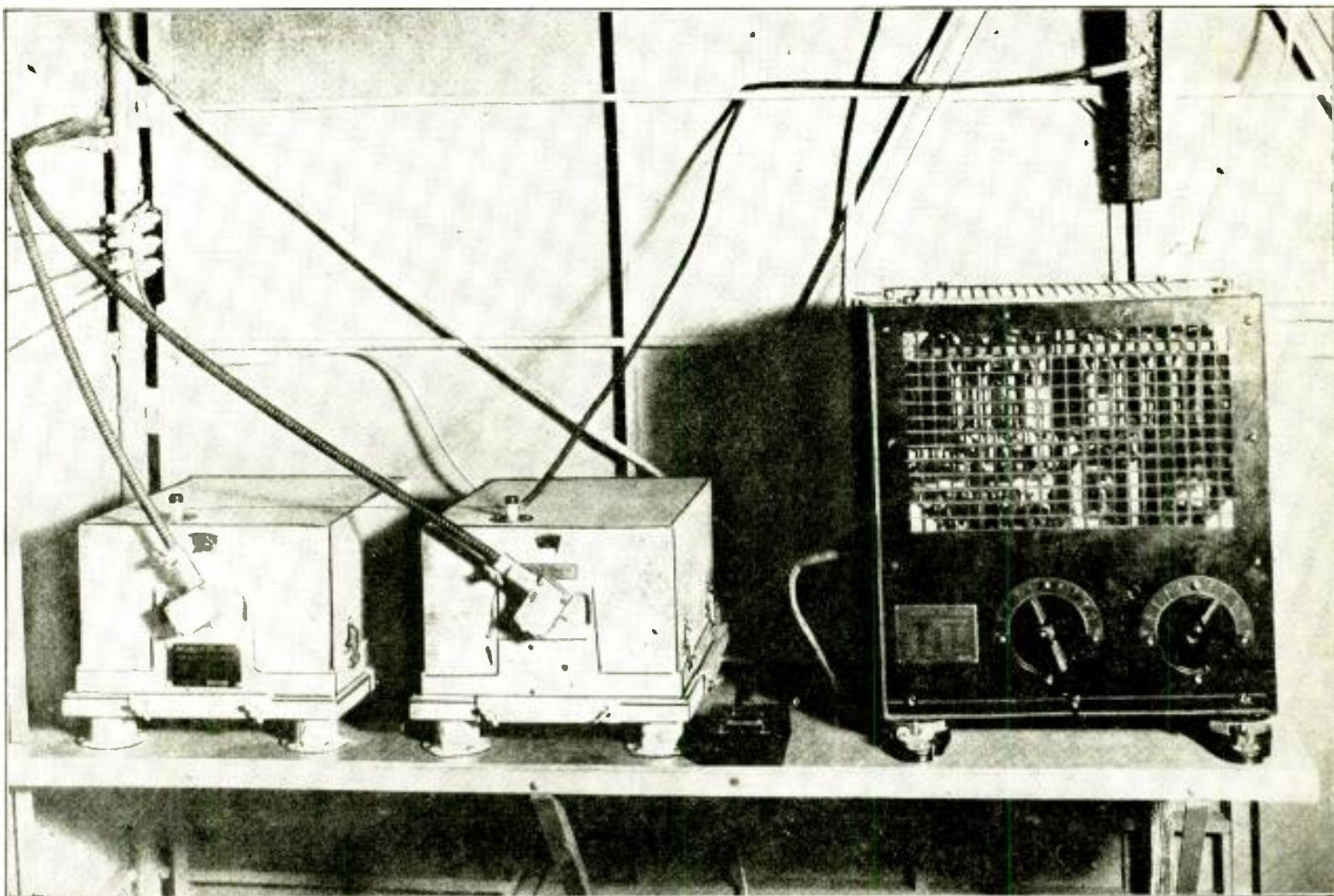

A very interesting photo showing long-wave radio receiver, also short-wave receiver, and radio transmitter installed in the tail end of the

fuselage of a large airplane. Flexible shafts connect the tuning condenser shafts of the receivers, with remote control dials in the pilot's cockpit. Photo courtesy of Western Electric Company.

been consistently carried on since that time. But this was the first public demonstration.

And the public felt that something miraculous had happened. One city editor, for instance, when his reporter telephoned and announced that he was phoning from a plane flying 1,500 feet in the air over New Brunswick, New Jersey, slammed up the receiver and said to his colleague across the desk, "Jones is full again".

Because of the publicity given to this demonstration it is often supposed that the purpose of the radio telephone is to enable a passenger on an air transport liner to call his wife and order dinner. Nothing could be further from the truth.

The apparatus is not, under any circumstances, for the use of passengers. In fact, a personal call might block the transmission of a message warning the pilot of "danger ahead" with the lives of his passengers at stake. The equipment is intended solely for the purpose of dispatching and instruct-

ing planes just as the telephone provides the same factor of safety in the dispatching of railroad trains.

The air navigation act of 1926 provides for establishment by the government of airways throughout the United States. These are to be

lighted and equipped to give weather reports and radio beacons. This work has progressed rapidly and there are now 27 weather broadcasting stations and 9 government beacons. There are also 11 additional broadcasting stations under construction and 28 new

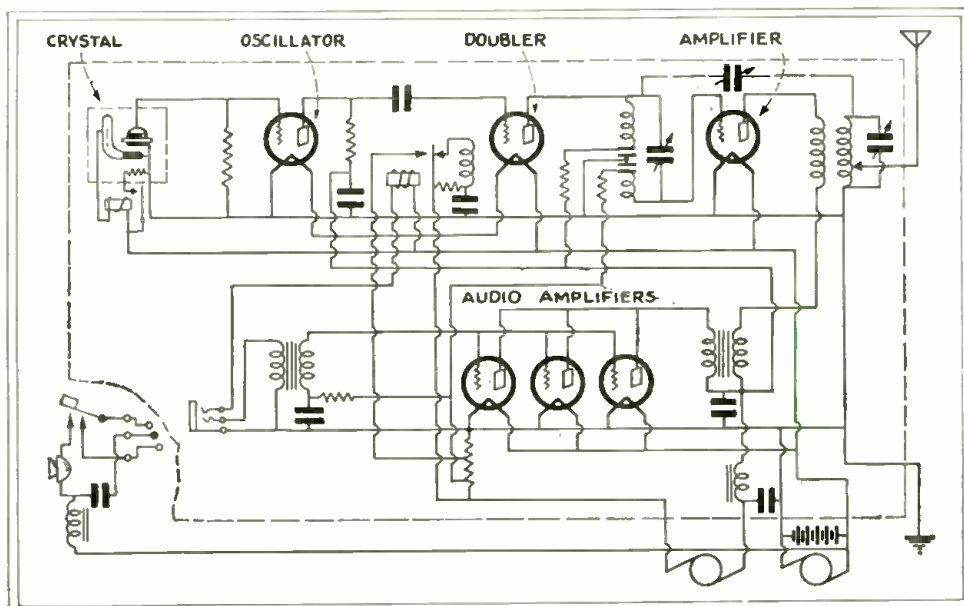

Schematic hook-up of Western Electric Co., airplane transmitter.

radio beacons. These are given on frequencies of 285 to 350 kilocycles. A proposed expansion of this band would extend it to include the frequencies between 250 and 350 kilocycles.

The application of radio for use in the aviation industry may be divided in three heads.

1. Reception of government weather and beacon reports.
2. Air Transport Company two-way dispatching.
3. Airport and itinerant flyer two-way communication.

For safety in flying the importance of accurate information concerning weather conditions is universally realized. With a Western Electric long wave receiver pilots are able to get spoken reports from various weather broadcasting stations. These concern not only local weather conditions but conditions along the entire route both in back and front of the pilot. This enables him to determine his course. If he is flying over an established route he is able to pick-up beacon signals as well as weather reports. These beacons given a continuous note signal if the flyer is on the course. Otherwise a dot-dash signal is received. Obviously, therefore, the first radio equipment to go into a plane is a long wave radio receiver.

This, however, is only the first step. When a pilot leaves an airport at the present time with an air transport line he immediately assumes full responsibility for a

This picture shows remote control dials mounted in the pilot's cockpit of new Fokker airplane, model F-32. By means of this simple control panel the pilot or his assistant has full control of the tuning, volume, etc., of the radio apparatus mounted in the tail of the plane. Long, flexible shafts connect the control dials here shown with the radio sets mounted in the plane's tail.

—Photo courtesy of Western Electric Co.

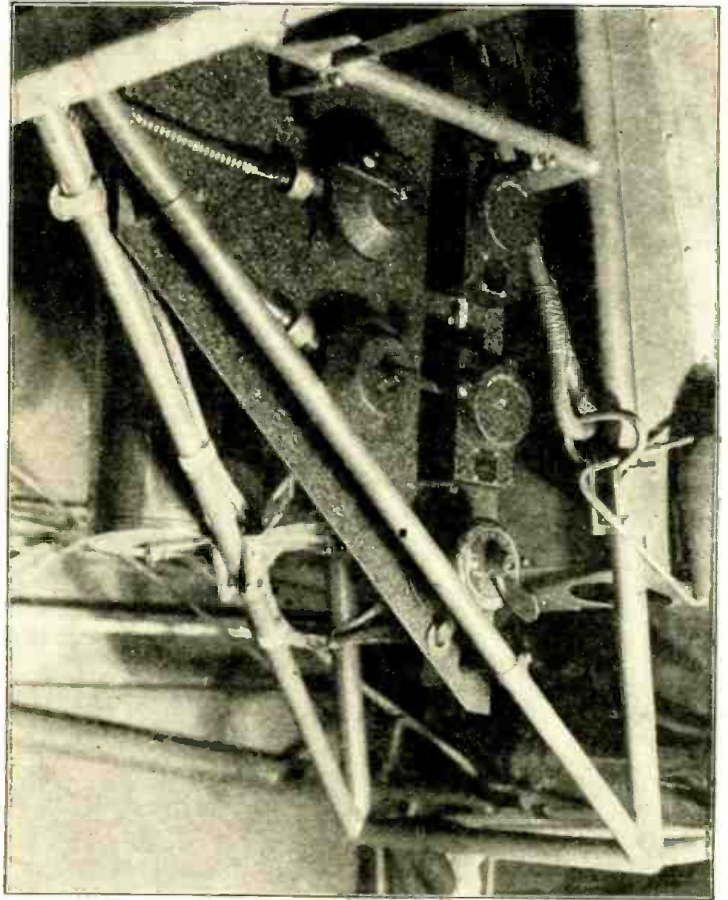

plane which represents an investment of from \$30,000 to \$100,000, including the value of the mail and express load that he is carrying, and, most important of all, for the lives of his passengers. The transport owner had no way of getting orders or instructions to the pilot until he arrived at the next landing. There is now a means of communicating with him and that is by radio. However, it is not enough to be able to signal from the ground to the plane. Two-way telephone conversation is essential to safe flying.

The radio telephone, therefore, comes as a great asset to aviation. It is used for dispatching exclusively. The man on the ground can instruct the pilot exactly what to

do. The pilot, on the other hand, finds himself in a position to report all conditions, make inquiries and in an extremity, report a forced landing. He is no longer lost. He has direct contact at all times with one or two ground stations. If he is in need of help after a forced landing, he can summon it. Spare parts that he might need or assistance of any kind can be rushed to him immediately from the nearest point.

All this may not seem essential to one unfamiliar with flying. But, to anyone who has flown through fogs and bad weather, it is a gift for the skies. Any pilot will tell you "I do not need anything in good weather because I can see everything. But in bad weather, when neither sky nor ground is visible, I must depend on radio."

The installation of radio equipment in an airplane must be considered even when the ship is under the process of construction. Any two metal parts rubbing together will cause a static discharge. It is necessary, therefore, to have all metal parts wired together and bonded to a common ground. All spark plugs must be

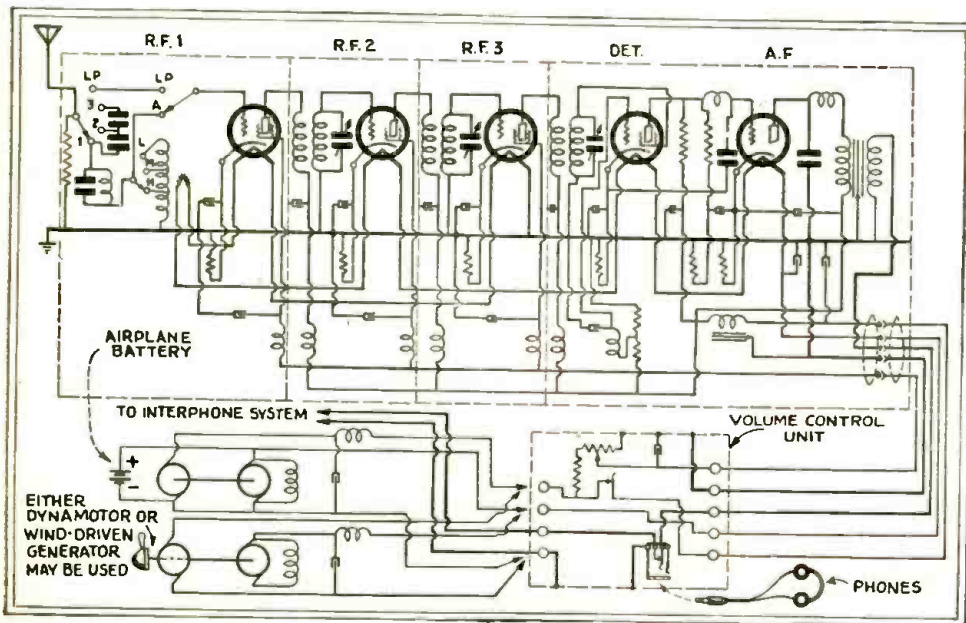

Schematic diagram of the Western Electric Co., short-wave, aircraft receiver.

(Continued on page 172)

A High Quality 75 WATT Short Wave Transmitter

By JERRY GROSS

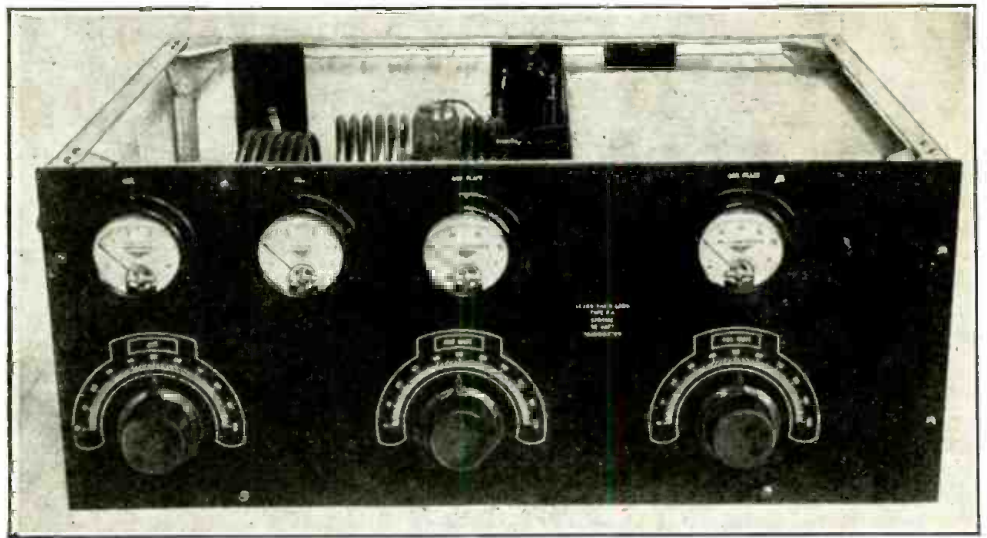

Front view of the 75-watt short-wave transmitter designed and built by Mr. Jerry Gross, radio engineer, Leeds' Radio Laboratories.

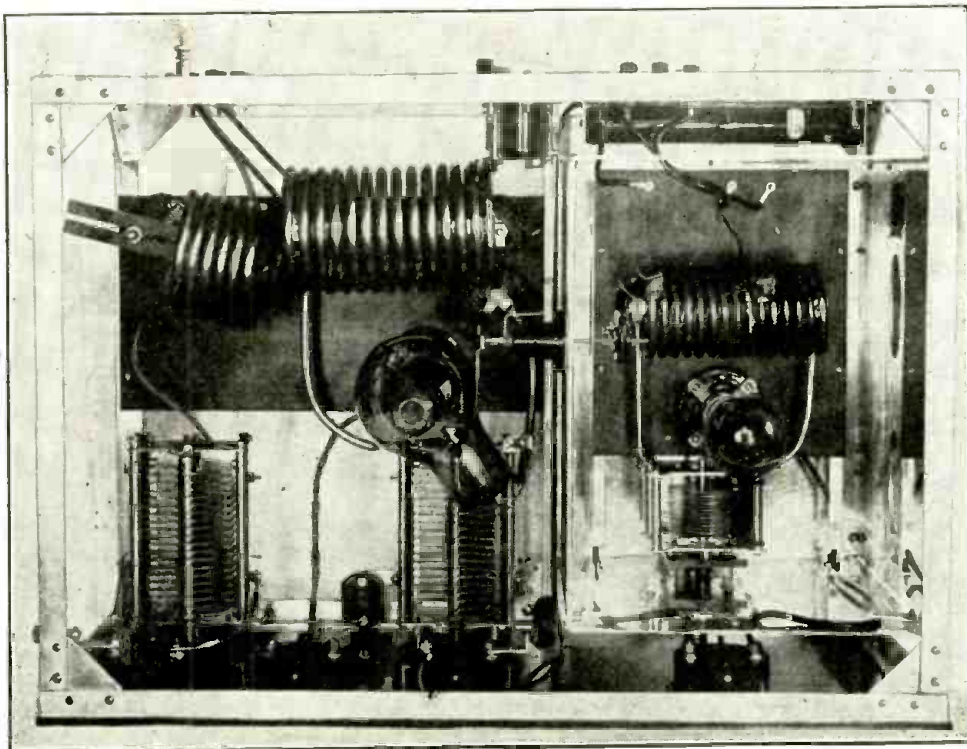

Top view of 75-watt short-wave transmitter—oscillator at right and power amplifier at left.

wound of pure copper tubing, to reduce all of the high frequency losses to the lowest minimum possible. The high frequency connections in the oscillatory circuits are made either with heavy woven, flexible metal ribbon or else with copper tubing. The condensers used are the well-known Cardwell make and the meters mounted on the front panel are Jewell instruments. The front panel is specially engraved with clear reading dials and titles over each milliammeter and voltmeter, designating what particular use they are being put to.

This transmitter can be used with any type of short-wave aerial and counterpoise or a ground may be employed if desired. For code work the key is connected across the terminals marked "key" in the diagram, and to minimize sparking at the key contacts, a 500-ohm resistance, connected in series with a 1-mf. condenser, is shunted across the key.

The master oscillator indicated at the right of the photo showing the top view calls for the use of a 7.5-watt '10 tube; the power amplifier or output stage of the transmitter calls for a UX-852 75-watt tube. Further details in next issue.

FOR private radio communication requirements, particularly those met with in connection with the operation of small and medium sized ships, including private yachts, there is a considerable demand for a high-quality short-wave transmitter. The 75-watt short-wave transmitter illustrated by the accompanying photographs and diagram is a specially built job intended primarily for telegraph code transmission. Where it is desired, a phone modulator panel and necessary tubes are supplied to convert this transmitter for the transmission of speech.

The metal frame supporting all of the instruments, which are of the very best quality, is made of aluminum, screwed together with hand-fitted aluminum brackets. Bakelite panels and sub-panels are used and all of the inductances are hand

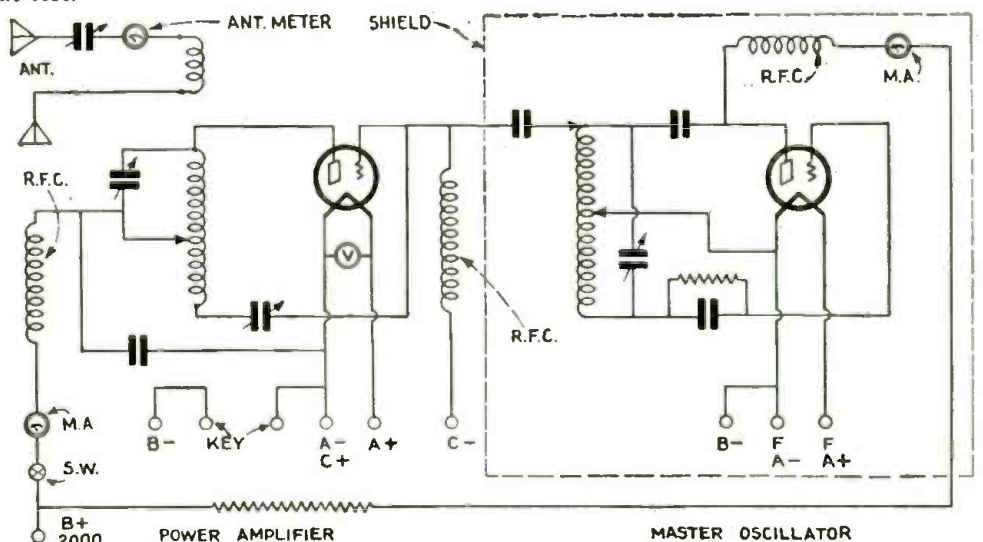

Connection diagram for the 75-watt short-wave transmitter here described.

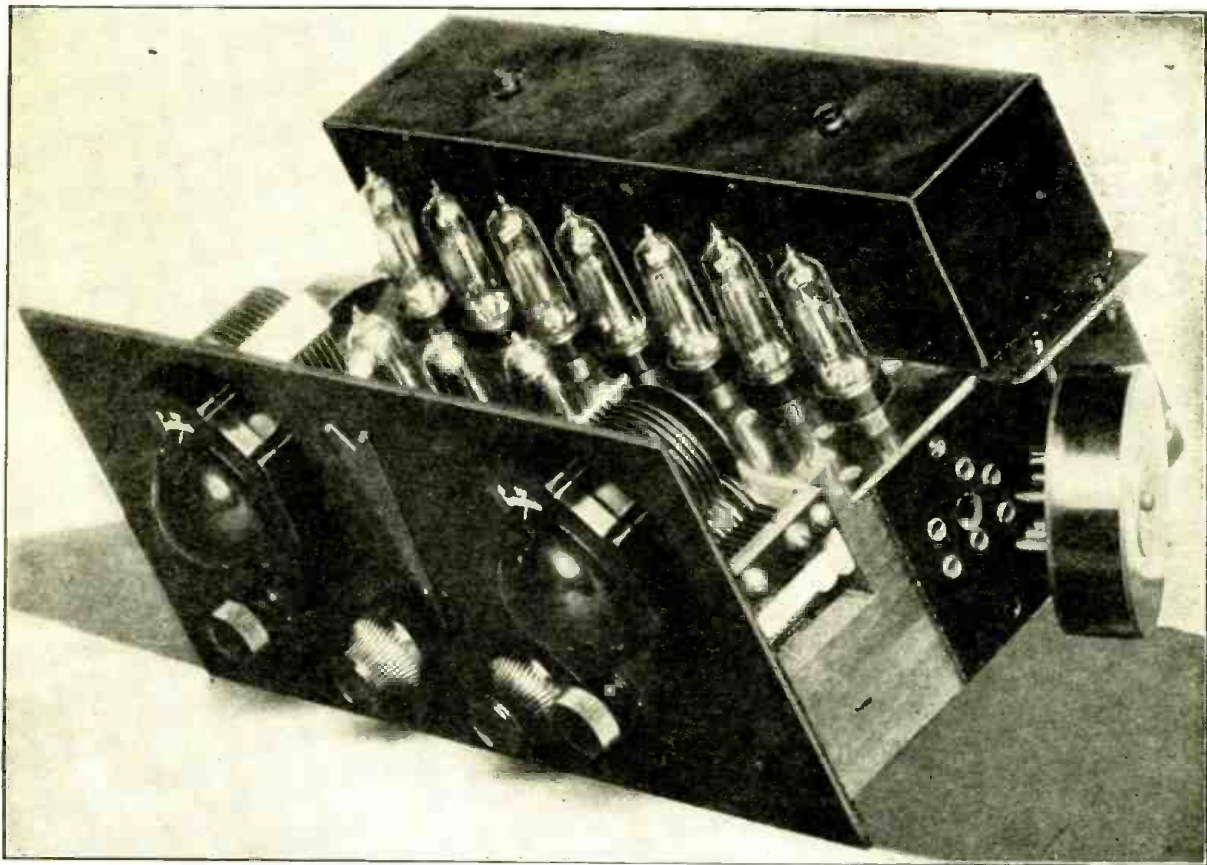

Appearance of the "Mercury" 10-tube short-wave super-heterodyne receiver.

The Mercury Super-Ten Short Wave Receiver

FOR many years the "Mercury" has been one of the leading radio sets produced in Canada. Custom built for the discriminating person who wants only the best in radio, it has always been manufactured to a standard of perfection.

The "Mercury" is a short- and long-wave superheterodyne using ten R215A, or "peanut" tubes, as they are commonly called. These are used by the U. S. Navy in their superheterodynes; they

This short-wave super-heterodyne has a brilliant performance to its credit. It has picked up transatlantic and trans-continental stations. The receiver uses peanut tubes, is battery or electrically operated and coils are available to cover wavelengths from 9 to 30,000 meters.

are rugged, require very low filament current, have extremely long life and the type is one of the most sensitive ever produced. They are inherently quiet in operation, very stable and non-microphonic, and therefore ideal for automobile service, where vibration is great and the filaments are subject to severe shock.

The voltage required by the "peanut" tube is 1.1, and the filament-current consumption is ¼-ampere. When ten of

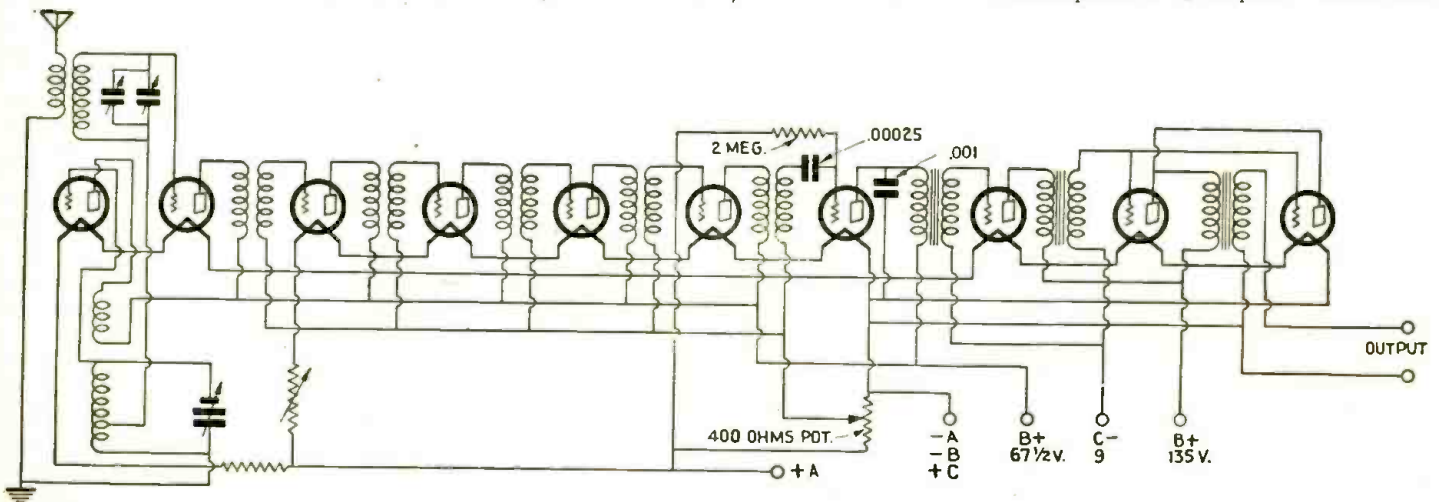

Wiring diagram of "Mercury" super-het for short-wave reception. The peanut tubes are connected in series-parallel.

these tubes are used in series-parallel, the total filament voltage is 5.5 to 5.6 with ½-ampere consumption. The maximum drain on the "B" supply, which is 135 volts with 9 volts "C" bias, is 12 milliamperes. A 6-volt storage battery makes an ideal "A" supply.

Four Intermediate Stages Used

Four stages are used in the intermediate-frequency amplifier, which is tuned to 247 kilocycles. The set is carefully shielded, yet not in such a manner as to have too much metal distributed about. Too much shielding depreciates a great deal from the efficiency of reception on the high frequencies. There are two stages of audio amplification, with output transformer. The amplification is very high and sufficient to operate a dynamic speaker with good volume and quality.

The "Mercury" receiver is capable of tuning to wavelengths from 9 to 550 meters. For the shortest bands, 9-22 and 22-32 meters, advantage is taken of a split condenser, which permits the tuning of these two wavelengths by the 3-plate section. When the long-wave coils are inserted, an extra pin in the coil automatically connects these two condenser sections together, enabling the set to be used on these series of wavelengths without any other change whatever. This arrangement leaves the oscillator and tuner coils adjacent to their respective tuning capacities. The panel and dials are of bakelite. There are two of the latter, which allows extremely fine adjustment and manipulation. There is practically no metal in the dials, and the receiver can be quickly and accurately tuned. There is a noticeable absence of metal in the set, except where it is absolutely necessary for shielding, and this feature tends to raise the efficiency. There are no body-capacity effects whatever.

The Mercury has jacks for either loud speaker or phones. The chassis is 18 inches long by 6¼ inches high by 7 inches deep. The same manufacturer is now putting out a special long- and short-wave, 10-peanut-tube set for automobile use, which will be just as effi-

The "Scout" model of the "Mercury" super-het for short-wave reception.

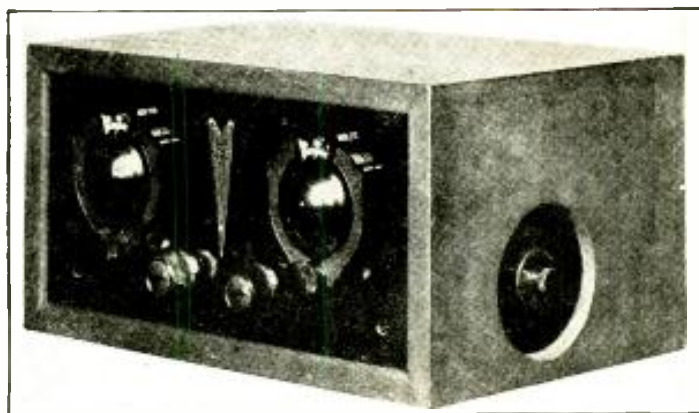

cient as the standard sets, it is said, although it will only be 12 inches long, 5¾ inches high, and 7 inches deep. This could almost be called a pocket set, so compact is its construction, yet it has all the efficiency of the large sets. These receivers can be operated economically on a four-cell dry battery, which should furnish the "A" supply for a period of 60 hours, intermittent use. For continuous use with dry batteries, eight dry cells wired in series-parallel are recommended.

Range 9 to 30,000 Meters, If Desired

Plug-in coils can be supplied to cover the wavelengths from 9-22 meters, 22-32, 32-80, 80-190, 190-550 and up to 30,000 if desired, although the manufacturers do not recommend anything above 550 meters, except for those reading code.

This receiver is one of the pioneer short-wave receivers, having been designed for the purpose fully a year before the broadcasters started even their experimental broadcasts on these high frequencies.

The "Mercury" is the set that was used to pick up, for rebroadcast, the bulletins on King George V's health during his illness, and also a series of Australian programs last year. For twenty consecutive days, CFCA, the station of the *Toronto Daily Star*, Toronto, Canada, rebroadcasted the chimes of Big Ben in London, England, using a standard "Mercury" with short wave coils

as the pick-up link with G5SW, Chelmsford, England.

Long-Distance Daytime Reception Possible

The Royal Canadian Mounted Police supply a large number of these receivers to their stations in the Far North, in the Yukon, and on the shores of the Arctic. They do not divulge for what purposes these are used, but require them for their tremendous reaching-out capabilities on the different wavelengths, and for long-distance reception in the daytime. In the Far North there are two months when the sun is never below the horizon and continuous daylight prevails. Under these conditions the receiver will handle distance up to 2,000 miles on the standard wavelengths, and it is for this reason that so many of these receivers are used in the remote districts of Canada. On the shorter wavelengths in those out-of-the-way locations reception is of such a wonderful nature that they can listen in to all parts of the world without any difficulty whatever; and as they are so close to the European stations they come in "over the top" like locals.

The Hudson's Bay Company, who have many stores and posts throughout the north of Canada, are purchasing more of these sets from time to time for these isolated points, which are out of touch with the world through lack of communication for periods of six and eight months, and sometimes a year, at a time. Arrangements are made with short-wave stations to broadcast news and messages for these outposts at predetermined periods.

Owing to the extremely low requirements of the ten peanut tubes used in the Mercury circuit (the "A" consumption is but ½-ampere), a rectifier of the cuprous type can be used, and this system has been found most satisfactory. This power apparatus, designed only for the Mercury and not suitable for other receivers, operates on 110-120-volt, 25-, 50- or 60-cycle A.C. current supply.

This short-wave receiver is furnished in chassis form or the manufacturers supply a cabinet when desired, at an extra price.

What Each Tube Does

The first photo shows the layout in general of the "Mercury Super-Ten"

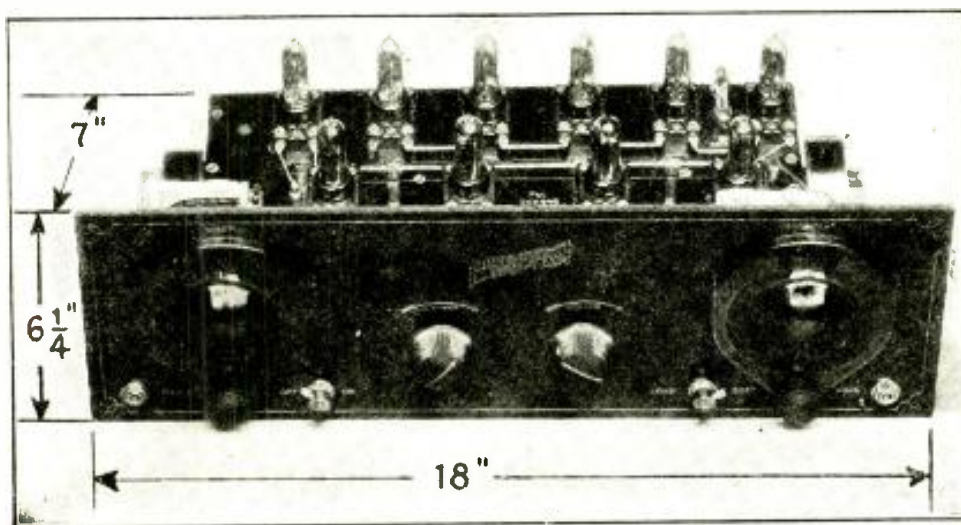

This picture of the super-het shows over-all dimensions of the chassis.

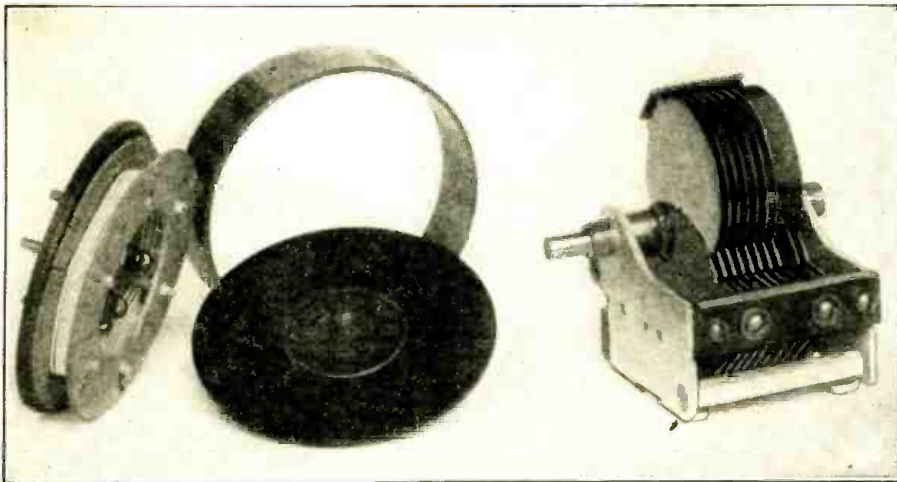

This photo shows the oscillator coil and a tuning condenser. The coil is of the Morecroft type.

short-wave receiver. The ten tubes incorporated in this circuit are wired in series parallel, with five tubes in each bank. Their positions are as follows, beginning from the top left side: (1) first detector; (2) first stage intermediate-frequency amplification; (3) second stage I. F. amplification; (4) third stage I. F. amplification; (5) fourth stage I. F. amplification; (6) second detector tube. The first tube in the front row on the left is the first stage of audio, the next two tubes are the second stage, and the fourth tube is the oscillator. The tubes used are the Northern Electric "R215A" type; the filament voltage is 1.1 and the amperage 0.25. As the ten tubes are wired in series banks of five each, and connected in parallel, the voltage required is 5½. This set operates from a 6-volt storage battery as standard battery equipment.

The two tuning inductances, shown on each end of the radio and audio unit, are removable. They are in very close proximity to the tuning condensers.

On the panel at the extreme lower left edge is a jack for phones, and on the extreme right lower corner is a jack for the loud speaker. The switch on the right serves as the means of throwing in a resistance on local stations, when the set is used as a standard-wavelength receiver, to cut down the volume. The two knobs in the center control the oscillations and volume of the receiver; the one on the right is a potentiometer and the one on the left controls the amount of current fed to the filaments of the radio-frequency bank of tubes. The resistance in the other bank of tubes is fixed.

Oscillator Coil and Tuning Condenser

The second photo shows the oscillator coil and a tuning condenser.

The coil is designed after the Morecroft pattern, and is much more efficient than some types of solenoid coils. The cover of this coil is of polished bakelite. The copper spring pins make a firm, lasting and non-corroding contact. Wooden pegs hold the fiber forms together and the wire is wound on high-dielectric strips, so that moisture will have the

least possible chance of causing leakages in these coils. The contact of the wire on the strip is practically a point and only a minute portion of wire is in contact with this strip.

Also shown in this photo is an oscillator tuning condenser; this is a split type and comprises two variable capac-

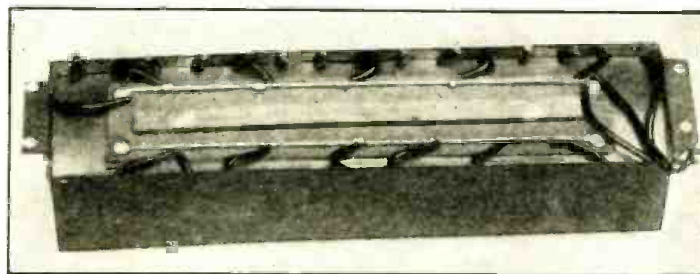

ities. The 3-plate section is for tuning on the ultra-short waves and the balance of the condenser for the short waves. This condenser also tunes the standard wavelengths, from 200-550 meters, when desired and covers this wave band from 200 to 550 meters with one set of inductances. The means of isolating these two capacities for their respective duties is accomplished automatically, when the coils are inserted.

The third photo shows the intermediate-frequency catacomb and the method of bringing the leads out. This unit is mounted directly under the row of intermediate-frequency tubes at the rear of the receiver; the grid and plate connections are 1 inch long. This cut shows the adjusting bar pulled down into position and the catacomb ready to mount.

Method of Controlling Oscillation Point

A unique method of controlling the oscillating point is used in this receiver. The coils are held in place by forms, and a convex copper shield with a scalloped edge is placed over them. The leads from the coils are then brought through in their respective places. This shield is convex, and does not come in contact with the interior shielding of the catacomb when resting in position before the adjusting bar is worked into

position. This bar has two brass screw studs which go through holes in the bottom of the catacomb; this is then pulled down until a tension is put on the brass convex cover, and the whole is then mounted into the set.

After the receiver has been completely wired and is on test, adjustments are then made with both these adjusting studs that come through the bottom of the catacomb, and by these, pressure is placed on this convex shield. This governs the amount of "leak" between the different shields, and the receiver can be thus brought up to exactly the point of oscillation, or held just below it as required. With these two adjustments it is possible to manipulate this intermediate-frequency amplifier to its highest peak of efficiency. After this has been secured, the adjusting nuts on the bottom of the copper box are sealed, no further adjustment being necessary. (This device is patented in both Canada and United States—in Canada under No. 226,848 and in United States under No. 1,697,923.)

The coils are of honeycomb construction and manufactured to a certain standard, which they have to pass before

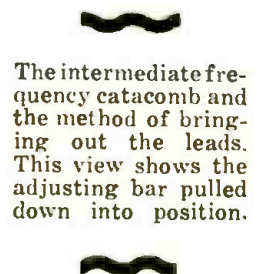

The intermediate-frequency catacomb and the method of bringing out the leads. This view shows the adjusting bar pulled down into position.

being placed in the receiver. This is accomplished by special machinery which has been developed for this purpose. A

(Continued on page 171)

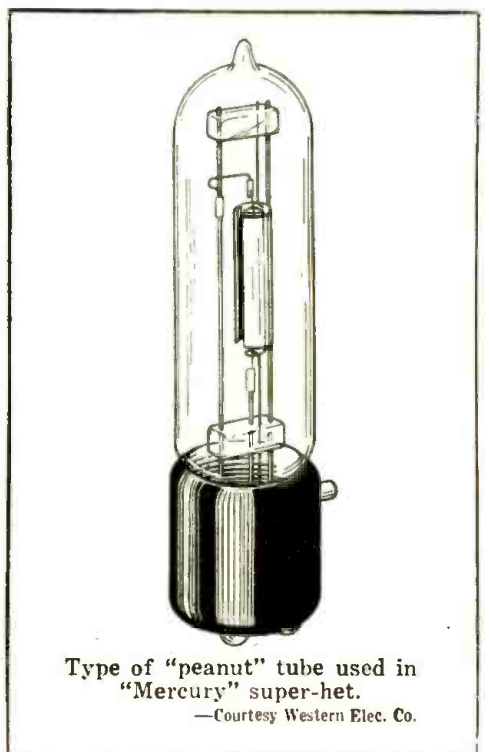

Type of "peanut" tube used in "Mercury" super-het.

—Courtesy Western Elec. Co.

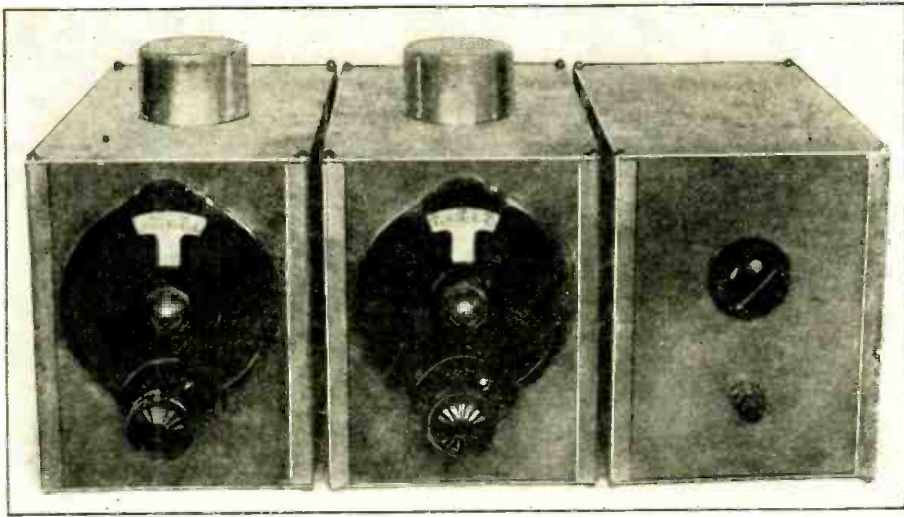

Front view of the "S-W Four" short-wave receiver.

Photos courtesy of Wireless Egert Engineer'g Co.

The "S-W FOUR" Receiving Set

THIS short-wave receiver owes its outstanding efficiency and sensitivity to the careful design and arrangement of the apparatus used in building the various stages. The apparatus, such as the inductances, are separated a suf-

ficient distance from all shielding so as to minimize losses. By removing the metal caps observed on the top of the shield cans, the plug-in coils may be removed and others inserted so as to change the set for reception of another

wavelength band. The grid-leads in this set are made as short as possible, which is an important factor in every short-wave receiver; in fact, all the connections in this set are made on the shortest
(Continued on page 165)

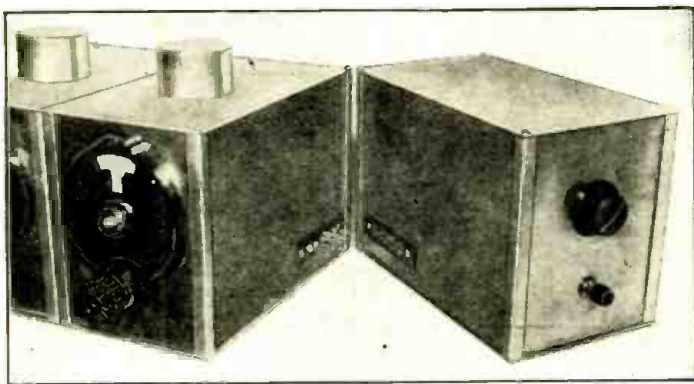

This photo shows how connections between the shield compartments are effected by means of jacks.

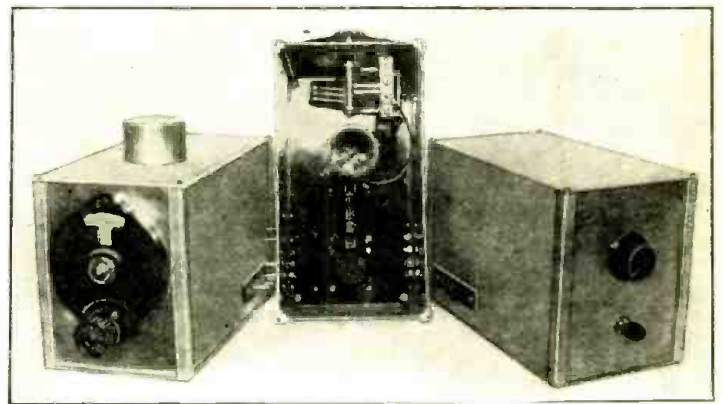

The three shielded compartments separated, with center compartment opened to show the apparatus.

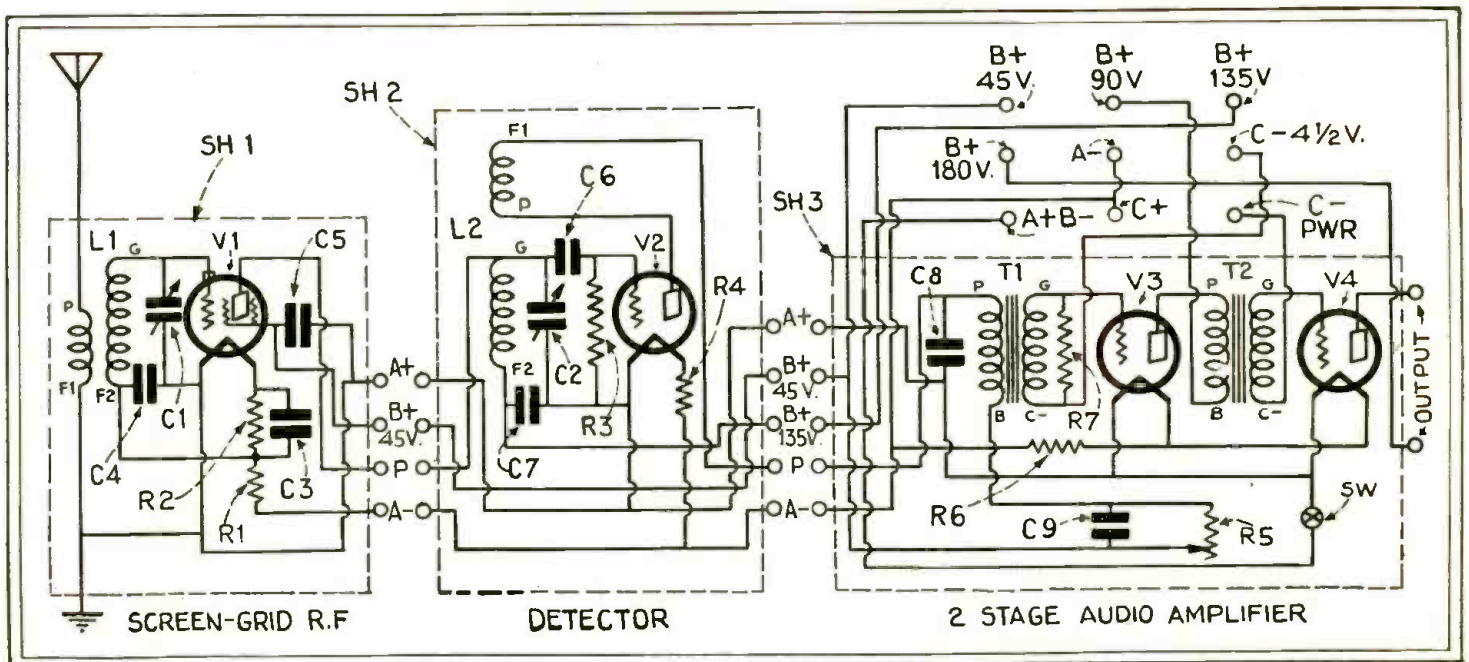

Complete wiring diagram of the "S-W Four" short-wave receiver, which has a trans-continental and trans-oceanic reception record behind it.

Short Waves for the Broadcast Listener

How to Build Really Efficient Short Wave Converters

By HENRY B. HERMAN

Mr. Herman describes in detail how to build highly efficient short-wave converters in contra-distinction to the ordinary short-wave adapters, which do not utilize the radio frequency stages of your broadcast receiver.

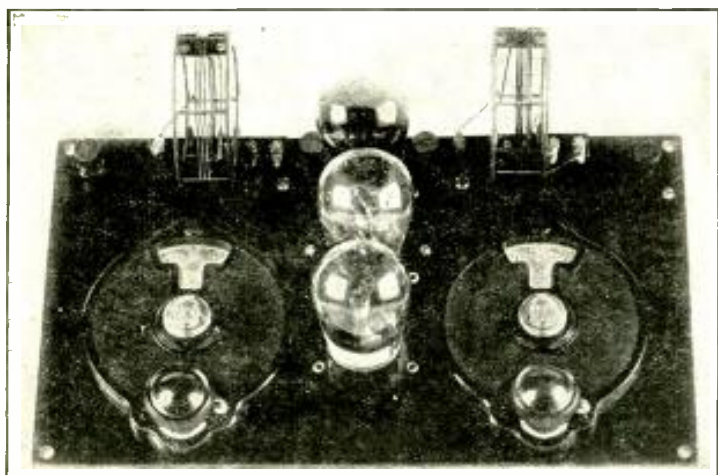

The illustration at the left shows appearance of the short-wave converter constructed from the specifications given in the accompanying article by Mr. Herman. It is a simple matter to tune in the short-wave stations, and the output of this converter connects with the aerial and ground posts of your broadcast receiver. All of the tubes in your set are put to work, which is not the case with the ordinary short-wave adapter.

good power supply. When the converter is used, all this equipment is effective. Nothing is left idle while the short waves are being received; nothing is cut out of the circuit; all is retained.

Now, if the selectivity of the broadcast receiver is good, that virtue is transferred to the short-wave combination. If the sensitivity of the broadcast receiver is high, the short-wave end will be correspondingly sensitive. If the quality is good, the quality of the short-wave reproduction will also be faithful. If the power supply is ample, it will also be ample when the converter is added. If the loud speaker in the broadcast receiver is high-class, it will be equally good when it is used on short waves.

Just as the broadcast superheterodyne is superior to the straight radio-frequency amplifier, so the converter is superior to the straight short-wave receiver. The superheterodyne is superior in selectivity, and for short-wave reception a high order of selectivity is essential; it is also superior in respect to sensitivity and, to receive distant short-wave stations, a high order of sensitivity is essential. Therefore, in these two

Advantages of the Converter

The advantages of the converter are so many and so great that there can be little doubt about its superiority. Everybody interested in short-wave reception has already a good broadcast receiver, one capable of high quality, sensitivity, and selectivity. It is provided with a good loud speaker and a

A SHORT-wave adapter is a device for plugging into the detector socket of a receiver, thus substituting short-wave input for broadcast input, while utilizing none of the radio-frequency amplifying properties of the receiver itself, although the receiver's audio channel and speaker are used to give suitable volume to the reproduction.

A short-wave converter is a device for receiving short waves, converting them to a lower frequency by the mixing process, and delivering this lower or intermediate frequency to the antenna winding of the receiver, so that the receiver is used *in toto*, with all its R.F. and A.F. amplification. The receiver is simply tuned to some frequency clear of broadcast reception (so that one a little above 1,500 kilocycles is desirable) and all tuning is done thereafter with the converter.

A short-wave receiver is a set that receives and reproduces short waves without the assistance of any other tuning or amplifying device.

It is therefore apparent that any one possessing a good receiver, with a high-gain radio-frequency channel and good audio amplification, can get better short-wave service out of a converter than he can out of an adapter, because an adapter discards the receiver's R.F. channel.

The diagram at the right shows connections of a battery operated, short-wave converter utilizing '01A type tubes. The plate voltages for the converter tubes may be supplied by the "B" source which now furnishes the plate current for your broadcast receiver, or a separate "B" battery may be used to supply the converter plate current. The same "A" battery or "A" eliminator which supplies your broadcast set may also supply the converter "A" current.

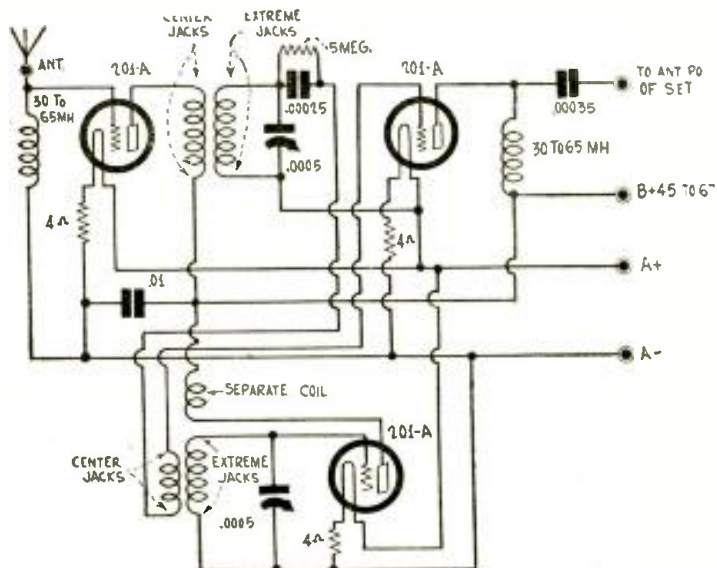

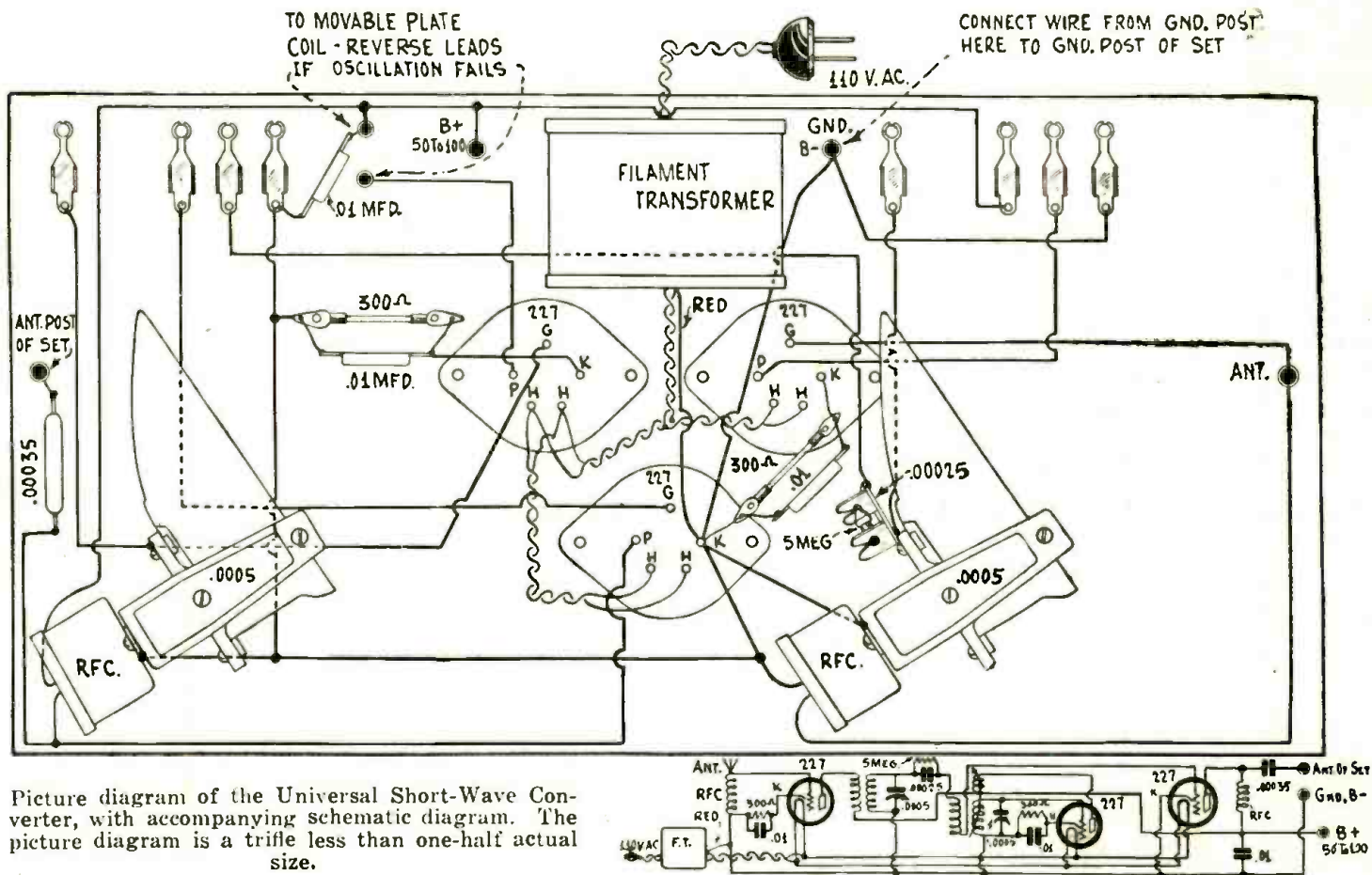

Picture diagram of the Universal Short-Wave Converter, with accompanying schematic diagram. The picture diagram is a trifle less than one-half actual size.

respects the converter is unquestionably superior to the adapter.

In point of cost the converter is in a class by itself. A device that will convert an existing broadcast receiver into a first-class short-wave receiver costs so little that no one will hesitate to get one, as soon as he is convinced that really worth-while results can be obtained with it. Perhaps the broadcast receiver cost \$100. A three-tube converter may cost \$25, if of the best type of construction; thus, for \$25, a short-wave receiver costing \$125 may be enjoyed.

The question of cost, it is admitted, does not enter into the question of which type will give the better results. But we have already given incontrovertible reasons why the converter will afford greater sensitivity and selectivity as against the adapter.

Construction of a Converter

The parts for such a converter may be disposed on a 7x14-inch bakelite panel which is fitted to a cabinet 3 inches high, so that the panel is on top.

The tubes may be arranged from front to back, or left to right; or triangularly as the diagram reveals them. At the left is the first tuned circuit, which receives the short waves from the antenna; at the right is the oscillator. Their coupling effects a beating of two frequencies and produces a difference-frequency equal to the intermediate-frequency established in the receiver proper.

The converter may be built to use A.C. tubes or battery type tubes. A converter of either type will work on any set, A.C.

or battery-operated; but both types rely on the receiver for "B" voltage. The A.C. converter needs a filament transformer, to take care of the 5.25-ampere heater current of three 227 tubes.

The data for winding the coils will be predicated on the assumption that bakelite or hard-rubber tubing is used; even though the commercial coils recommended are wound on ribbed forms, to afford 93% of air dielectric.

It is not practical to duplicate the commercial coils, as the ribbed forms are made by machinery and, unfortunately, are not independently available. Nevertheless, the same waveband coverage will be assured, even though the radio-frequency losses will not be so low when the standard bakelite or hard rubber forms are used.

Preparation of Coils

Get two pieces of bakelite, 2 3/4 x 1/2 inch and, on the central longitudinal line of each, drill four 3/32 machine-screw holes (No. 29 drill), separated from one another as follows: first hole, 7/8-inch from the end; next hole 1/2-inch from the first; third hole, also 1/2-inch from its predecessor; fourth hole, 1 1/4 inches away from the third. Both pieces of bakelite are drilled exactly alike, and will serve as the coil bases. In each of the four holes will be placed a prong like those used on the base of a tube or as phone tips.

Now get six round bakelite forms, 2 3/4 inches in diameter and 2 5/8 inches axial length, and drill two holes 2 1/4 inches apart, lengthwise, to correspond to the

outside holes on the bakelite mounting strips already drilled. Considering hardware, there will be a clearance of about 1/4-inch between the tops of two pair of prongs, for winding the primary, which has three turns of No. 24 single-silk-covered wire. Use the space between second and third prongs and put on this winding before the prongs are attached to the strip, or the strip to the circular bakelite form.

Between the prongs, 1 1/4 inches apart (or about 1 inch apart, considering the hardware at top) wind on the form three secondary turns of No. 18 enamelled wire, spacing the turns about the thickness of the wire. Anchor the beginnings and ends of wiring through two small parallel holes, which you drill in the circular form. Then attach the circular form to the mounting strip, by passing the hardware through the coinciding holes, and tightening down. It is preferable to put lugs at the top of the strip, and bakelite spaces between the strip and the circular form. Solder the terminals of the coils as follows: One secondary terminal to one outer prong; the other secondary terminal to the other outer prong; the primary to the two inside prongs. Make two such coils.

The same procedure is followed in making and winding the higher-wave coil, except, of course that the number of turns is different. Put on four primary turns of No. 24 S.S.C., and 17 turns, space-wound as previously, for the secondary, using No. 18 enamelled wire here. Make two such coils.

These two coils will cover the short-
(Continued on page 168)

A SHORT

This receiver can be used with a pair of 'phones to listen in on short-wave stations; it can also be used as a short-wave adapter for your broadcast set. The "Fun Box" has its own batteries and uses a '99 type tube; one of the new 2-volt tubes could be used.

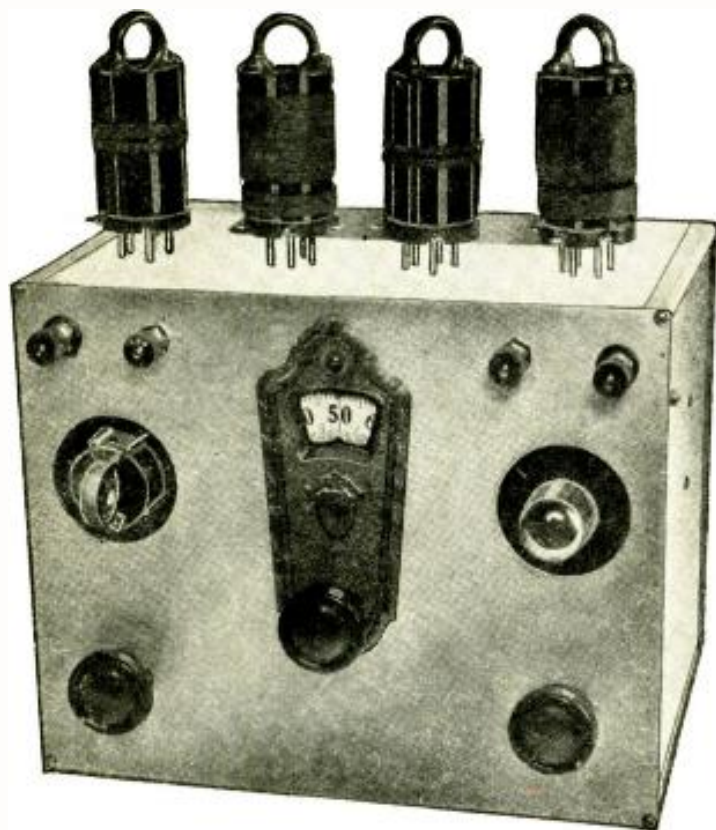

Front view of "Fun Box" short - wave receiver, which can also be used as an adapter for your broadcast set, enabling you to obtain loud speaker reception of short-wave stations.

Fig. 1 shows the front drilling plan. The size and location of all holes are not given, as these depend upon the particular parts employed. You may have spare parts which can be used, in which case dimensions can be taken from them. In the set illustrated a Pilot condenser and dial was used. Since the box is of metal, the rheostat 12 and the variable resistance 13 should be mounted on small bakelite pieces which are in turn fastened to the box, thus insulating them from the box. The antenna binding post and one of the output binding posts are likewise insulated from the metal box with bakelite washers. The other two posts are connected directly to the box.

ANYONE can assemble this simple self-contained short-wave receiver and enjoy the thrills of tuning in United States and foreign stations throughout the world. It is a one-tube set employing the battery type '99 tube, complete with batteries installed in the 10 x 8 x 6 inch aluminum radio shield can. You can pack it into a grip or carrying case and carry it wherever you go. After having acquired skill in the manipulation of the set with ear-phones, you can attach it with one wire

Construction of Set

Perhaps the first thing to secure is the aluminum shield can. The type specified comprises four grooved corner posts with tapped holes in the ends. The top, bottom and sides slide in the grooves and the front and back are attached to the corner posts with screws, holding the entire box in shape. The stock is $\frac{1}{8}$ -inch thick, which is sufficiently strong for supporting the parts comprising the set.

The audio transformer 1, and R. F. choke coil 3, and the condensers 4 and 5 are mounted on the bottom as shown at Fig. 2. These parts can be connected as illustrated with No. 18 copper wire covered with spaghetti insulation, before assembling the box. In many cases connection is made to the box as indicated, by the ground symbols in the illustrations. The resistance 2 is mounted on clips attached to the transformer ter-

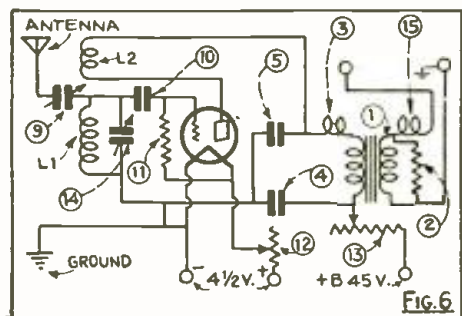

Above: Schematic diagram of short-wave receiver and adapter.

At right: Rear view of "Fun Box" short-wave receiver.

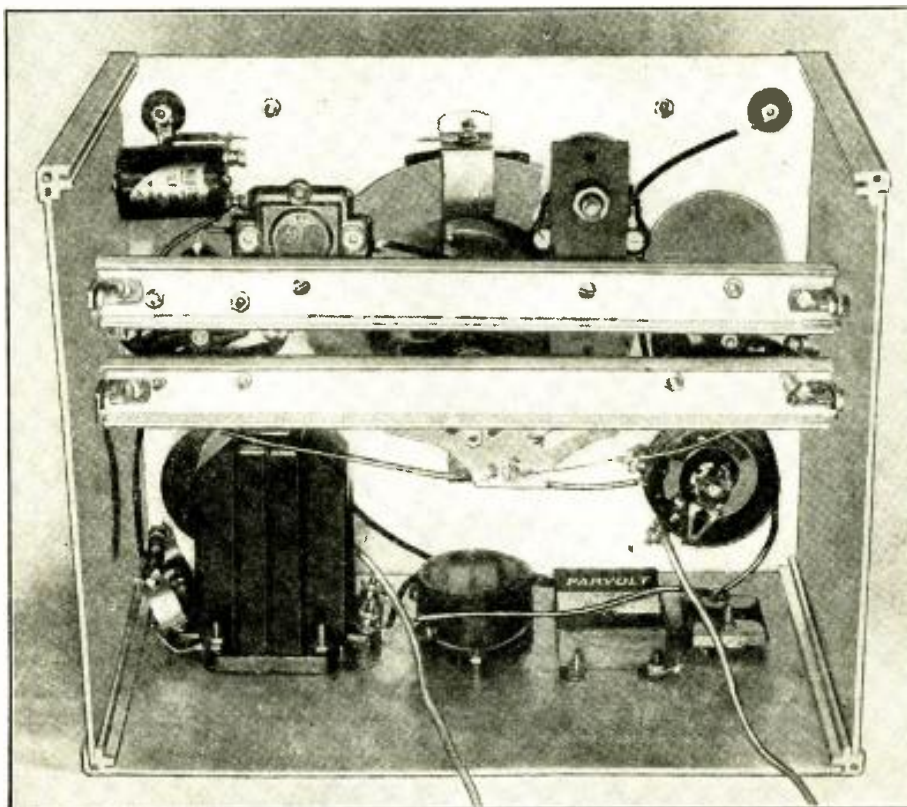

to the amplifier of your present broadcast receiver and enjoy loud speaker reception. Broadcast, as well as short-wave stations, can be received with the use of the plug-in coils. It makes an ideal set for the beginner who wishes to become familiar with amateur reception as well as for the broadcast listener who desires to explore the short-wave regions.

WAVE "FUN BOX"

By
CLYDE FITCH

minals. This resistance is only required when the set is used as an adapter.

Fig. 4 shows how the tube socket 6 and coil socket 7 are mounted on the aluminum channels. The grid condenser 10 and antenna coupling condenser 9 are also mounted on these channels as shown. The wiring is clearly indicated in the illustration. The grid leak 11 is mounted on clips attached to the tube socket. Note that the connections to the coil socket are for Pilot coils; if other coils are used these connections may be different.

The wiring for the instruments on the front is shown in Fig. 5. The other R. F. choke coil 15 is mounted on the left end piece of the box, looking from the back. The box may now be assembled, all but the back and top, and the remaining connections made. These are all shown by the letters in the various illustrations.

Fig. 3 shows a rear view with the batteries and coil shelf in place. Note

LIST OF PARTS

The parts are numbered to correspond with the numbers in the illustrations:

- (1) Audio frequency transformer.
- (2) 100,000-ohm grid leak resistance.
- (3) Short-wave radio frequency choke coil.
- (4) 1-mf. by-pass condenser.
- (5) .00025-mf. fixed condenser.
- (6) 4-prong UY type socket.
- (7) 5-prong UY type socket.
- (8) Bakelite strip 1" x 3" x 1/16".
- (9) 15-mmf. midjet variable condenser.
- (10) .0001 grid condenser.
- (11) 3-megohm grid leak.
- (12) Filament rheostat, 20 ohms.
- (13) Variable resistance, 50,000 ohms.
- (14) Tuning condenser, 150-mmf.
- (15) Short-wave radio frequency choke coil.
- (16) Aluminum channels, 7/8" x 3/8" x 9 5/8".
- (17) Bakelite shelf 9 3/4" x 2" x 3/16".
- (18) Blau radio shield can 10" x 8" x 6".

In addition there will be required one set of five Pilot short-wave coils: two small 22 1/2-volt "B" batteries; one 4 1/2-volt "C" battery; 4 binding posts; 1 type '99 tube; one pair telephone receivers; 8 small brass angles; wire, solder, screws, terminals, insulating washers, etc.

that the top of the box has a section cut out so that the four spare coils, shown standing on top of the set in one of the reproduced photographs, can be slipped into the paper tubes on the shelf. The battery connections are shown in Fig. 7. Two leads go into the set for the A+ and B+ connections. The A- is connected to the metal box. Of course, a "C" battery is used for the "A" battery in this case. The schematic diagram is shown at Fig. 6.

Operation

The set may be tested by connecting the antenna and ground wires to their respective posts, and a headset to the output posts. A coil and tube must be placed in their sockets also. The rheostat acts as a filament switch; this should be turned on. The 50,000-ohm variable resistance, mounted on the right (looking from the front) controls the regeneration; this should be adjusted, together with the tuning dial, until the set oscillates, and the heterodyne whistle

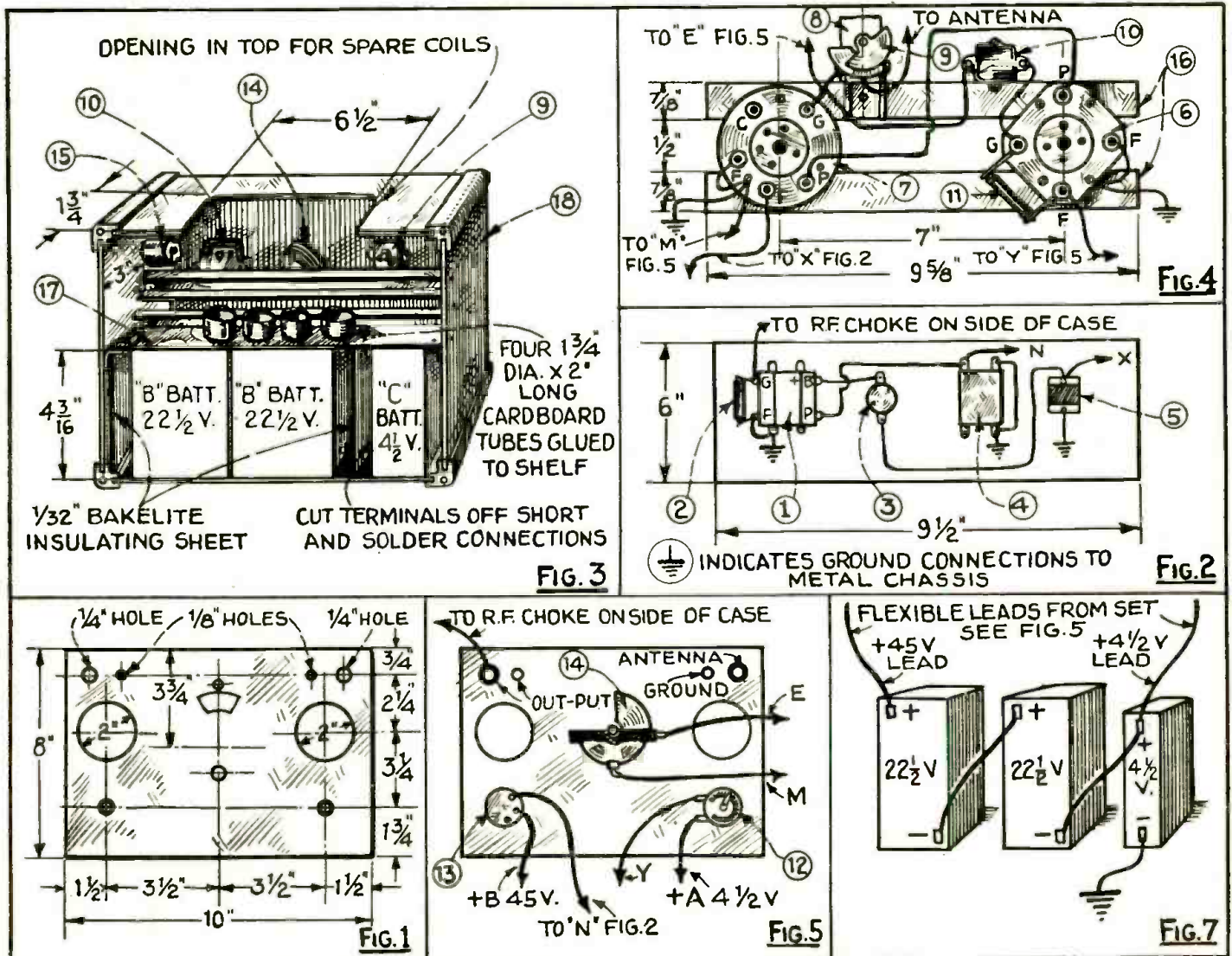

Details of construction which the builder will need are illustrated above.

of the short-wave stations is heard. A readjustment of the variable resistance to a point just below oscillation will bring in the phone stations at their best.

Using the different coils for different wavelengths may require a different adjustment of the antenna condenser 9 mounted inside. By slotting the shaft with a saw, this can be turned with a screwdriver by reaching in from the opening in the top of the box.

By connecting insulated output binding post—the one at the extreme right—to the grid of your detector in your

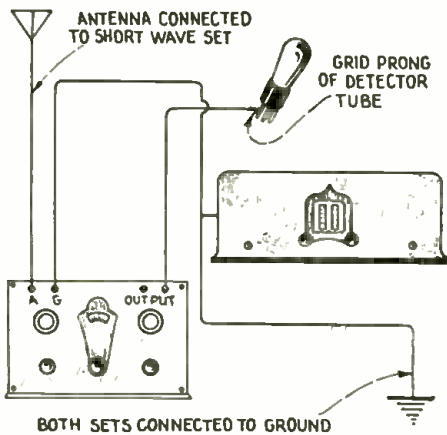

Fig. 8. How aerial and ground are connected to set and converter.

present broadcast receiver, the detector acts as an audio amplifier, together with the other two stages of audio amplification in the set, giving three stages in all.

The connection to the detector grid can be made by attaching a small wire to the grid prong of the tube and let it protrude sufficiently for a connection with a spring clip terminal. This is satisfactory in sets using a grid condenser and leak. In some sets no grid condenser and leak are employed, a "C" bias voltage being used instead. In this case it will be necessary to open the grid connection to the detector socket when tuning the short-wave set as an adapter. In many sets which have a plug connection for a phonograph pick-up, the output of the short-wave set can be plugged in, in place of the phonograph pick-up. The ground wire should be connected to both sets and the aerial connected to the short-wave set only when using it as an adapter.

Fig. 8 shows a clear idea of how the set is connected for use as an adapter. The detector tube of the broadcast set is removed, the output lead from the short-wave set connected to the grid terminal as shown, and the tube is replaced in the broadcast set.

As stated above, sets employing "C" batteries or bias on the detector tube cannot be used with this connection. A

good method would be to make an adapter as shown in Fig. 9. This consists of a vacuum tube socket mounted on a vacuum tube base, both, of course, for the same type of tube as is used for the detector; that is, either four-prong or five-prong. The socket connections are all soldered to the respective tube base prongs, with the exception of the grid terminal, which is left open. This is to be connected to the output lead from the short-wave set. Therefore, when the detector tube is placed in the adapter and the adapter placed in the empty detector socket in the set, all connections will be the same as usual but the grid connection, which is free and can be connected to the short-wave set as shown.

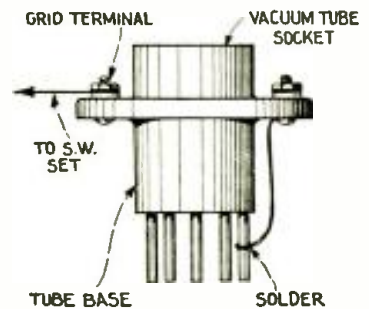

Fig. 9. How to make socket adapter providing a free grid terminal.

A Transatlantic Telegraph and Telephony Receiver

By DR. FR. NOACK (Berlin)

SHORT-WAVE operation on a continuous basis, it is well known, is subject to great difficulties, of which the effect of fading is the most important. A perfect short-wave receiver, therefore, can be attained only when fading is overcome. When that is done, also, it is necessary to bring the amplification to so high a value that the signals can be understood clearly at the most unfavorable moments of reception.

A short-wave receiver meeting these requirements is not impossible of attainment. It is customary to use a super-heterodyne for short-wave work, with a single stage of R. F. (radio frequency) amplification, perhaps, before the intermediate amplifier. It is well-known that an intermediate amplifier should not be pushed too hard; and, if we desire to meet the exacting conditions outlined in the first paragraph, it is desirable to use greater R. F. amplification ahead of the intermediate amplifier.

The Telefunken Company has recently designed a receiver for overseas commercial traffic which meets this description. Although it is manufactured equipment, it will be of interest to the constructor. The complete receiver has four stages of radio-frequency amplification which, without the use of regeneration, step up the incoming signals from 600 to 6,000 times ahead of the first detector. With the further amplification in the five-stage intermediate amplifier,

the output signal will reach an amplitude of 20 to 30 volts.

In order to shut out nearby high-power transmissions, the I. F. amplifier has a selectivity curve equal to that of a ten-tube receiver. It is well-known that with a super-heterodyne a station of a given frequency will appear at two places on the dial; but this is overcome by the extremely selective R. F. amplifier ahead of the frequency-changer. The selectivity is so great that the amplification of the desired frequency is 10,000 times that of a signal on the next channel; and an undesired station of 1,000 times the signal strength sinks below the interference level. In addition, the R. F. amplification puts so strong a signal on the grid of the first detector that the detecting action will be stable. By dividing the amplification between the two amplifiers, the danger of noise, always possible in the I. F. amplifier, is reduced.

With such a reserve of amplification, the fading of the received signal is compensated for. For code reception, a separate device is used to regulate the tone of the received signals in such a manner that the greater part of the interference is suppressed. The use of this apparatus has the advantage that the received signal may be kept at an audible level.

(We trust to find room in the following issue for the elaborate circuit and details of this receiver.—*Editor.*)

In Our Next Issue

Transmitting Newspaper Facsimiles by Short-Wave Photo-Radio.

Experimenting with Short-Wave Regenerative Receiving Circuits, by Clyde A. Randon.

An Inexpensive Short-Wave Receiver Built in a Cigar Box, by Louis F. Leuck.

Propagation of Radio Waves, and the Influence of the Earth's Atmosphere Upon Them, by Dr. J. Fuchs.

A Sensitive and Selective Short-Wave Receiver, by R. William Tanner (W8AD).

Experiments with 4-Inch Waves, by Pascal Bert.

"Quasi-Optical" Waves—Interesting Experiments with Waves Only a Few Inches in Length, by Henry Koppelmeyer, German Experimenter.

Profits in Short Waves for the Set Builder, by "Bob" Hertzberg.

How to Build the "HY-7" Short-Wave Super-Heterodyne, by I. W. Hatry.

Building a 20-Meter Radiophone Transmitter.

The Problem of Building A GOOD Short Wave RECEIVER

By J. E. SMITH*

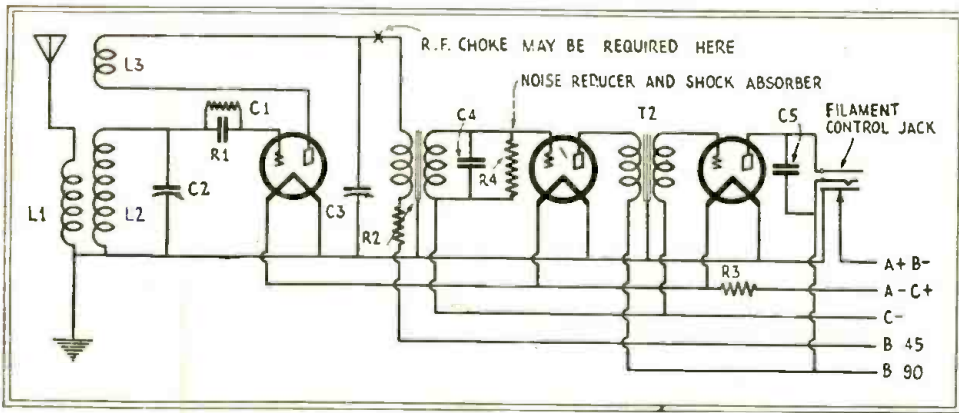

Fig. 1. Typical hook-up of a good regenerative short-wave receiver.

IT IS the purpose of this particular article to outline some of the problems of all stages of amateur requirements. The broadcast listener is very probably interested in the 5-, 10-, 20-, 40- and 80-meter bands; limiting himself in each particular band to those frequencies which are provided for the service in which he is particularly interested, to ease his job, or to listen.

The Simplest S-W Receiver

The simplest of all short-wave receivers is the three-circuit tuner: namely, the aperiodic primary, the tuned secondary and the fixed coupler with oscillation coupling by means of a variable condenser. Such a simple diagram is shown in Fig. 1, with the necessary reference facts in the appended table, and a semi-pictorial diagram of how the coils can be made in Fig. 2. With such an outfit, the ordinary broadcast listener can no doubt obtain a maximum amount of interest and satisfaction to compensate for the efforts he has put into short waves.

In building any short-wave receiver, it is absolutely important to consider problems which, in the ordinary broadcast band from 550 to 1,500 kilocycles, were considered relatively unimportant; to see that the capacities of the coil windings themselves be carefully kept down at all times. The minimum capacity of the condenser is important; so it is imperative under such conditions to use the appropriate type of variable condenser. The grid and plate capacities of the tube also play an important part and it is, therefore, essential that the grid and plate leads shall be as short as physically possible and as far away from one another as they possibly can be placed.

It is absolutely important that the radio-frequency current be confined to

those circuits in which they belong. Blocking condensers should be used profusely but intelligently. It must be borne in mind that these by-pass or coupling condensers should have as little leakage as possible, in order to conserve the weak radio-frequency current.

Shielding Details in S-W Receivers

It is also far more important that you use shielding in a short-wave receiver than in the ordinary broadcast

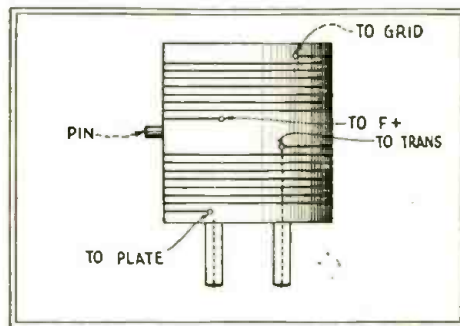

Fig. 2. How plug-in coils are made.

band; by this we mean shielding against hand capacities or between the relative stages. Of fundamental importance, that against hand capacities; in which case a plain aluminum panel, for mounting the condensers and control dials, is sufficient. It is not absolutely imperative that the balance of the circuit be placed in an aluminum container although it is quite advantageous for mechanical reasons. On the other hand, if we are trying to separate the various radio-frequency stages of a short-wave receiver (assuming that we are building a multi-stage short-wave receiver) it is very necessary that every possible hole for connections between the two stages of the shield shall be as small as pos-

sible. It is also imperative that the corners shall be evenly soldered, in the case of copper shields, and have large overlaps in the case of aluminum. Short-wave interference, unless these precautions are carefully observed, will get through. Then, too, we must not overlook the fact that the coils must be kept as far away as possible from the shields themselves. The shields should not be of thin material but of a thickness sufficient to shield one stage effectively from the other. With copper, a thickness of 30 mils (.03-inch) seems to be quite reasonable. In the case of aluminum, a thicker or substantial piece of metal should be used, with an overlap of half an inch wherever possible.

At present, the commonest short-wave receivers are the single- or the three-circuit tuner; and they seem to work efficiently for telegraph purposes but fall short of efficient performance when used for telephonic and television reception. The three-circuit and the single-circuit tuners are vicious oscillators and will regenerate into the air, creating disturbing interference; and, with the rapid growth of short-wave operation, the same problems will confront the country that were experienced in the early days of broadcasting. Furthermore, the single-circuit tuner is not selective, in spite of the common opinion that such a tuner is very sharp; should you ever try to operate such a receiver in the presence of a powerful local short-wave transmitter, you would be easily convinced of the fact. Or should you, at any time, try to separate stations only 10 kilocycles apart, again this fact would be clearly driven home. Again, voice or television reception is poor on a regenerative receiver.

The tendency, therefore, is to get away from simple regenerative receivers, and in the near future we will have short-wave receivers of either the tuned-radio-

(Continued on page 172)

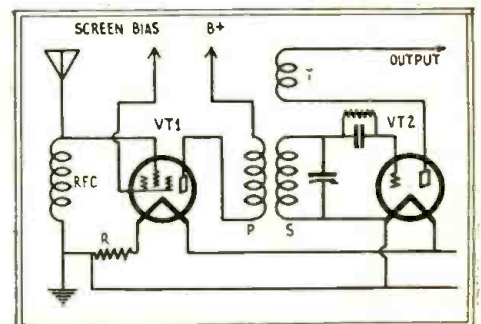

Fig. 3. Connection of R. F. stage with screen-grid tube, ahead of regenerative detector.

*President, National Radio Institute.

The Short Wave Experimenter

Three Useful Short Wave Wrinkles

By A. J. GREEN

THERE is much room for experimenting in the short-wave part of radio. Everything from the antenna to the output of the set presents an opportunity for exploration into the

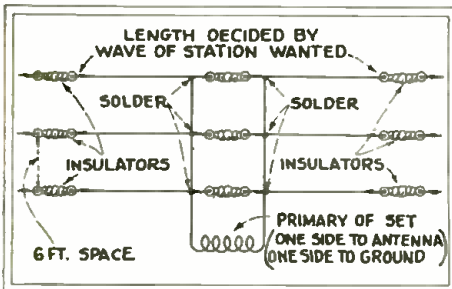

The wave to which this antenna is tuned is predetermined by the builder, using the simple formula given in the text.

mysteries of this fascinating game. Often the experimenter runs into trouble on one end or the other and herewith is presented three wrinkles that may help a number of fans interested in getting the best out of their sets.

Tuned Antenna System

The first is a tuned antenna system. This is a modification of those used by many stations for re-broadcasting overseas stations, etc. The wave to which this circuit is tuned is predetermined by the experimenter before it is built. Many fans are particularly interested in picking up a certain station whose wave and schedule is known. Almost every distant station has its list of ardent admirers. The circuit can be built for any certain station or for any band of stations such as the 31 and 49 meter bands where most International broadcasts take place.

To determine the length of the wire to use, multiply the wavelength by the figures 1.56. The result will be the length in feet of the entire length of the wire to use for that station. This is then cut in half and an insulator placed in the exact center. The lead-in is

taken from both sides of this insulator and the three strands are joined together by these two lead-in wires. One takes the place of the regular aerial and the other replaces the ground in the set.

As an example, to find the length of wire necessary for a station on 31.3 meters we multiply this by 1.56 and the result is 48.82 or 48 feet and 9½ inches. This represents the amount of wire in one whole length. Dividing this in half we have 24 feet 4¾ inches, the length of each single strand. Six of these lengths are needed to complete the system.

Short waves are semi-directional and added to this each aerial has a natural wavelength and is subject to dead spots in the tuning range. This is especially noticed in

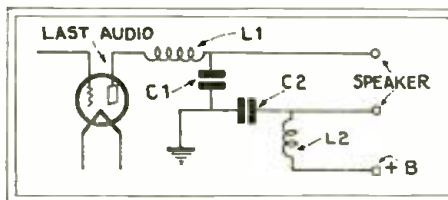

How to eliminate howling of loud speaker by connecting two choke coils L1 and L2, and two condensers C1 and C2 in the manner shown.

straight regenerative sets where no radio frequency precedes the detector stage. To overcome this, three or four aerials of different length and running in different directions is advisable where the experimenter has the space for such equipment.

Loud Speaker Howling

Ofttimes the loud speaker attached to a short-wave set has a tendency to howl. To eliminate this use the circuit shown herewith. The coils L1 and L2 are simple choke coils made by winding a layer of fine magnet wire on a common spool on which regular thread comes. The condensers are the ordinary .00025 grid condensers.

Adding a last or third stage of audio often means the difference between loud speaker and head-phone reception on short waves. Adding the third stage is sometimes a task as there is often a feedback causing the audio end to howl continually. The transformers must not be placed close together and after some experimenting the writer built his in the following manner with good results. The parts needed are a transformer, preferably of a low ratio, a filament ballast to take care of the make of tube used, a binding post strip and a socket. If a power tube is used there must, of course, be more "C" bias and more plate or "B" current.

Mount the parts on a board about four inches square, fitting them so all of them can be put on the board. Fasten everything down securely and wire it up in regular audio style. Then mount the entire thing in some out of the way place such as under the radio table up-side-down, inside the battery cabinet or some place where it will not be seen and not be too close to the regular set. Ten inches of separation is plenty. Then make the battery connections and watch the result.

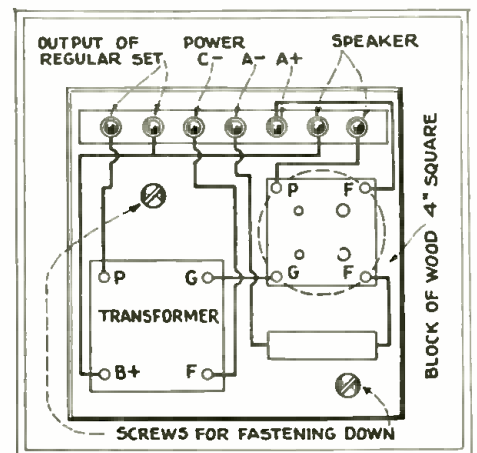

Compact arrangement of third stage of audio amplification, to be used on short wave sets where more power is needed.

The "SUN" Short-Wave Tuner

The simplicity of an efficient, one-tube short-wave radio set built by the author for code or voice has been accentuated in the construction details of this receiver

By
JACK GRAND

SHORT-WAVE tuners are attracting quite a following among the set builders, experimenters and even owners of factory-built sets. The reports of extreme distance, excellent reception during summer months, and the experimental possibilities offer diversion for those that feel that they cannot find anything new in the present broadcast band.

The author, desiring to build a short-wave tuner, set about getting parts at as low a cost as possible. To speed the construction and assure accuracy of parts, units were to be made of standard make and easily obtainable.

The result was surprising. First, the low cost—less than \$11.00. Next the appearance, which can be judged from the photograph. The set is compact and very efficient. By using the base of a tube as a cable plug, the tuner can be used as an adapter.

Building the tuner is very simple as there are only seven parts to wire: (1) The tuning condenser, C2; (2) The antenna condenser, C1; (3) The regeneration condenser, C4; (4) The radio-frequency choke, L3; (5) The grid condenser and leak, C3 and R1, respectively; (6) The tube socket, V1; (7) The coil socket, G, F—, P, F+. The rest of the kit is made up of panel, baseboard, binding-post strip, switch, and dial.

Constructional Details

For convenience of the constructor, in addition to efficiency in design, connections should be direct and as short as possible. The simplest and most satisfactory way of wiring is to start at the filament. Run a wire from the "F—" on the tube socket to the resistor R2 (4-ohm if a 201A tube is used, or 50-ohm if a '99 type is preferred), and from R2 to the "A—" battery post. Next, from

"F+" on the same socket to one side of battery switch, and from the other terminal on switch to "A+B—." Then from "Ant" post on strip to one side of the antenna condenser C1; from the other side of C2 to "G" on coil socket; to stator of tuning condenser C2, and to the grid condenser C3; from the other side of the grid condenser to "G" on tube socket. Wire from "F—" on coil socket, to rotor on

tuning condenser C2, to "Gnd." post, also to one side of switch and to one side of regeneration condenser C4. From the other side of regeneration condenser, to "F+" on coil socket; and from "P" on coil socket to one side of the R. F. choke L3, and to "P" on tube socket. The other terminal of the R. F. choke leads to one side of the phone binding posts, and the other phone post connects to the "B+45"

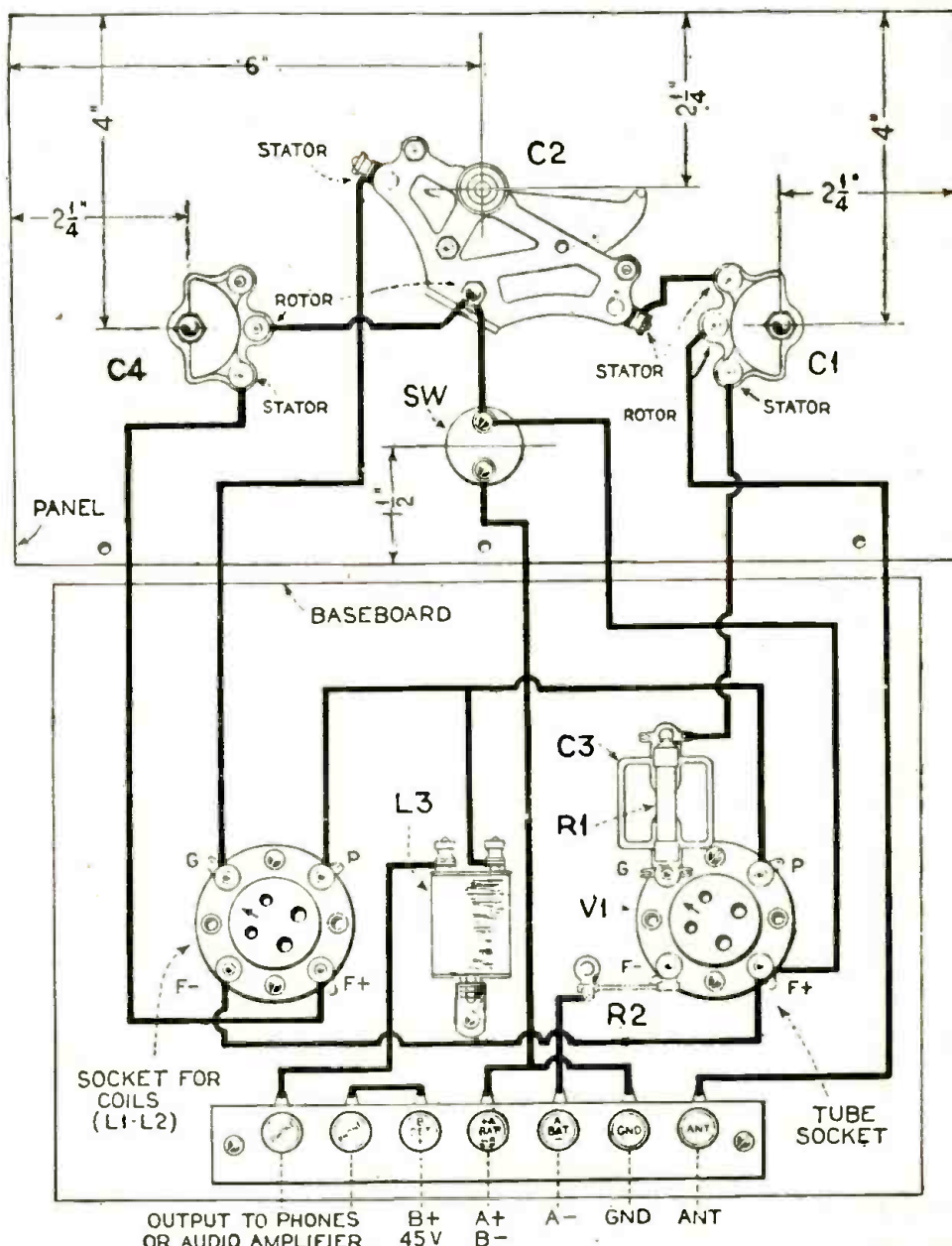

Layout of parts for the Short Wave Tuner.

post. That is all there is, for construction.

To cover the wave band from sixteen to two hundred twenty-five meters, four coils are required (each coil is 1½-in. dia.) as the following table indicates:

Color	Meter Range	No. of Turns, L1	No. of Turns, L2
Green	16-30	6	6
Brown	29-58	13	13
Blue	54-110	21	15
Red	103-225	54	27

With the Broadcast Receiver

To use this tuner as an adapter, the base of an old tube socket can be utilized. First, obtain three lengths of wire about four feet long, one wire to be soldered to the plate prong of the tube base. This wire is connected to the phone binding post connecting to the R. F. choke. The other two wires are to be soldered to the filament prongs of the tube base and connected to "A+" and "A—" binding posts.

When this is completed the tube base is to be inserted in place of the detector tube in the set. The detector tube in the set is to be placed in the tube socket of the adapter.

As a tuner good results may be obtained with head phones; but much stronger signals will be heard with two stages of audio.

Distance, of course, is a matter of location and at all times the

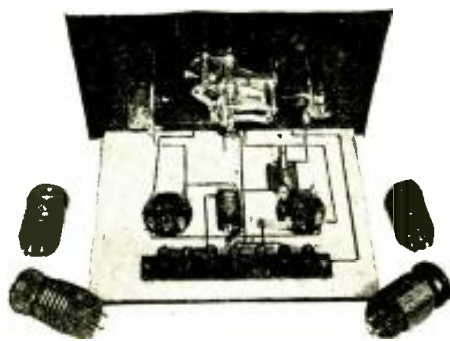

Above is pictured the short wave receiver described in this article. All primary coils may be wound with No. 28 enameled wire; the secondary coils may be wound with Nos. 12, 14, 16 and 28 (green, brown, blue and red units, respectively) wire. The first three are bare and the last is enameled.

short-wave receiver is superior to a broadcast set in this respect.

When tuning for distance a chart should be obtained, showing at what time stations are broadcasting.

The following is a list of parts used in the "Sun" Short-Wave Tuner:

- 1—Set of four Octocoils (L1-L2)
Green coil, 16 to 30 Meters
Brown Coil 29 to 58 Meters
Blue Coil, 54 to 110 Meters
Red Coil, 103 to 225 Meters
- 1—R.F. Choke Coil (L3) (Pilot, 80 millihenry)
- 1—.00005-mf. Midget Variable Condenser (C1) (Pilot No. J-13)
- 1—S.L.F. .00015-mf. Variable Condenser (C2) (Pilot No. 1608)

- 1—.00015-mf. Grid Condenser (C3) (Aerovox)
 - 1—.0001-mf. Midget Variable Condenser (C4) (Pilot J-23)
 - 1—Binding-Post Strip (7 posts) (Eby)
 - 1—7"x12" Panel (I. C. A. "Insuline")
 - 1—8-Megohm Grid Leak (R1) (Carborundum)
 - 1—Fixed Resistor (R2) (Yaxley) (50-ohm for 199 tube or 4 ohm for 201A tube)
 - 1—Filament Switch (SW) (Carter)
 - 2—UX Tube Sockets (Pilot)
 - 1—Pilot Vernier Art Dial; 6 feet of wire
 - 1—8"x11" Wood Baseboard.
- (Courtesy Radio-Craft)

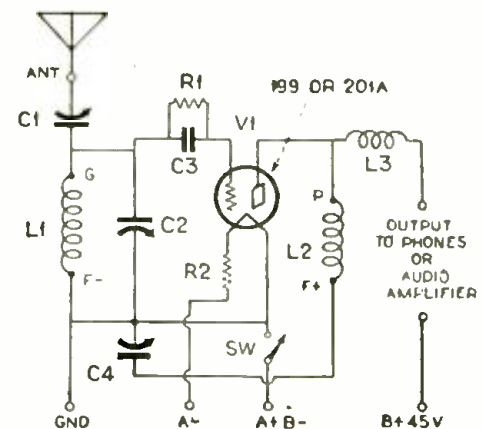

Schematic circuit of the Short Wave Receiver described in this article by Mr. Grand.

Low-Loss Coil Construction Simplified

COMMERCIAL developments in short-wave apparatus have made it extremely simple for even a beginner in the short-wave field to build good receivers, to say nothing of the more advanced constructor. In this connection, the Delft Radio Co. has recently announced a special coil-winding kit

which allows one to construct accurate coils of optimum electrical characteristics with minimum effort and time. The kit was developed by A. Binneweg, Jr., a well-known short-wave radio engineer.

The form itself (Fig. 1) is a threaded hardwood cylinder cut into three lengthwise sections, and is provided with bolts

for holding the form together while the wire is wound in the threads.

To wind a coil, the wire is first secured to the end of the form, and then wound in the threads (thus giving perfect spacing for the turns of the winding). The wire is wound over a thin skeleton framework of celluloid strips, to which the finished winding is cemented with a special low-loss cement.

When the coil is completely wound, the bolt at the end is removed and the form is "collapsed" by removing the center section. The coil can then be slipped off. Often it is found most convenient to make a long winding, and then cut coils of the desired number of turns from the long winding.

The kit itself comes complete with wire, skeleton forms, the special form, cement, sufficient wire for many long windings, a brush, and full instructions giving coil sizes for different wavebands.

—By CLYDE A. RANDON.

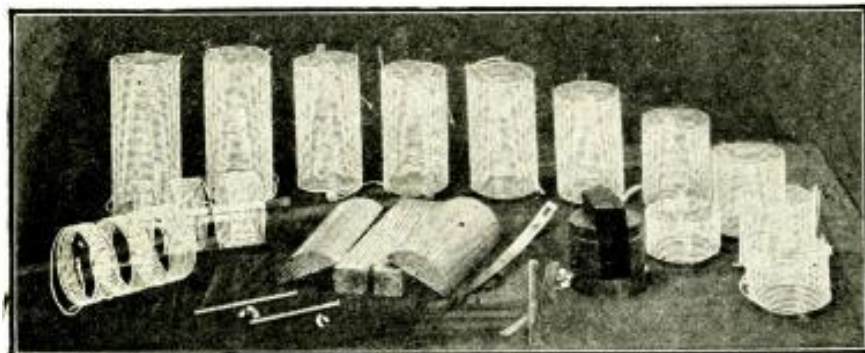

Coil winding form and samples of coils produced on it.

A Simple 5 METER Transmitter and Receiver

By E. T. SOMERSET, G2DT

BY far the simplest, combined with efficiency, is the balanced circuit shown; wherein practically any tube can be made to oscillate and run hot. The variable capacity consists of two brass plates 4 x 1½ inches, and separated by ¼-inch; these plates stand vertically, as plainly shown in the photograph, and are mounted on stand-off insulators, by means of angle brass soldered to the plates and screwed to the insulators. They are made to open away from each other by the simple expedient of an eccentric round bakelite tube, of 1 inch diameter, to which is attached a rod passing through to the control panel. As this rod is rotated, in an eccentric manner, so are the plates opened and closed.

The inductances are both made from 12-gauge soft-drawn copper wire; they

How the 5 meter transmitter looks from the rear. This is the one used at G2DT (England) in an effort to bridge the Atlantic.

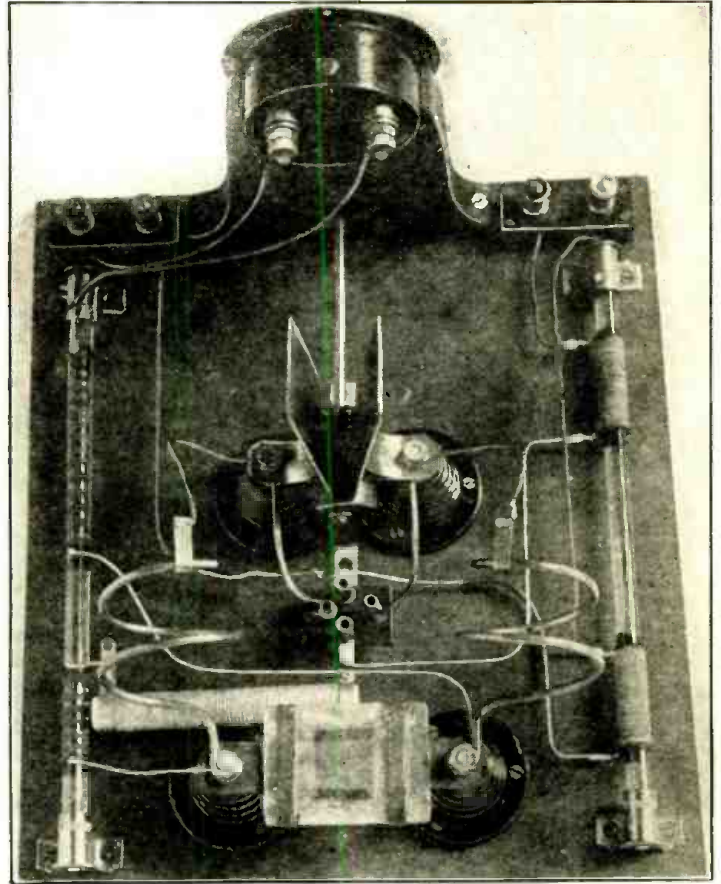

Nowadays, with improved tubes, it is not quite so difficult to get a receiver or transmitter down to 5 meters as in days past; but in either case the instrument requires the expenditure of a good deal of thought in its layout or it will be found (as so often the case) that it is impossible to get below, say, 7 meters!

For a receiver the conventional Reinartz-Grebe circuit can be used with every hope of success; but the stumbling block is the variable capacity, and the reason is this:

If a variable condenser of, say, 50-mmf. is used it will be found that the receiver will tune from 5 to 5.36 meters, or, expressed in frequencies, from 60,000 to 56,000 kilocycles. Now, this is obviously far too much, for it will be realized that with such a coverage, a transmitting station would be completely passed over without detection. Therefore, it is necessary either to make a special variable condenser, such as two strips of brass about 1 x 4 inches (the one forming the rotor and the other the stator,

separated by a wedge, suitably operated so that by opening and closing the brass plates, it varies the capacity in minute form); or else by taking a condenser (such as the R. E. L. adjustable) and moving the single stator about ¼-inch from the single rotor; or, again, by removing all but two plates from the usual short wave variable condenser and spacing these.

The inductance will usually be a single turn of No. 12 copper wire, about 2 inches in diameter, and fixed direct between rotor and stator. Beware of pig-tails; which are more likely than not to set up much noise, apart from altering capacity as the pigtail winds in or out. If possible use a baseless tube and thus cut out the capacity of the tube base as well as that of the socket.

Usually it will be found to be easier to get a tube like the '12A to oscillate on such high frequencies. If it will not do so right away, then try increasing the "B" voltage; which will generally do the trick.

(Continued on page 167)

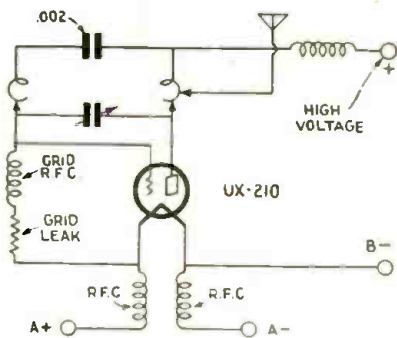

Hook-up of the 5 meter transmitter:

are 2 inches in diameter, spaced 1 inch, and consist of 1½ turns. Referring to the photograph, it will be seen that they are supported on two stand-off insulators with the grid blocking condenser in between; their other ends are free and connections are made from stator and rotor by means of flexible leads with clips. This is better followed in the circuit diagram, wherein it is also plainly shown how to connect the 16-foot, pure voltage-feed Hertzian antenna. The grid R. F. choke may be made on a glass rod 1½ inches in diameter, of five sections, close-wound with 10 turns of No. 28, and spaced ¼-inch between sections. The grid-leak value is 5,000 ohms.

Here is the hook-up of 5 meter receiver employed by G2DT—a very interesting circuit.

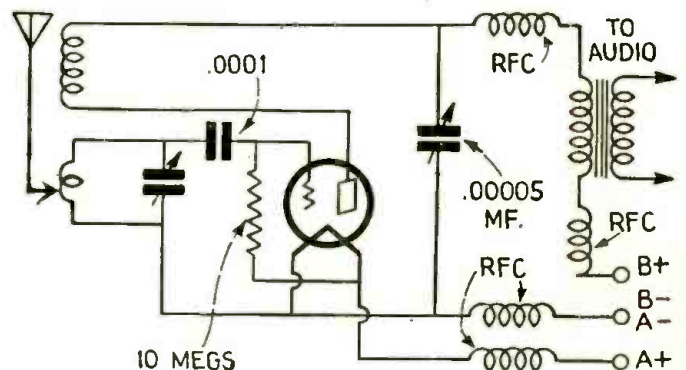

The LEUTZ Short Wave RECEIVER de Luxe*

Mr. Leutz is one of the leading designers of custom built radio receivers in this country. The two models of short-wave receivers here described are excellent examples of his skill. These receivers employ two stages of shield grid R. F., and three stages of audio amplification.

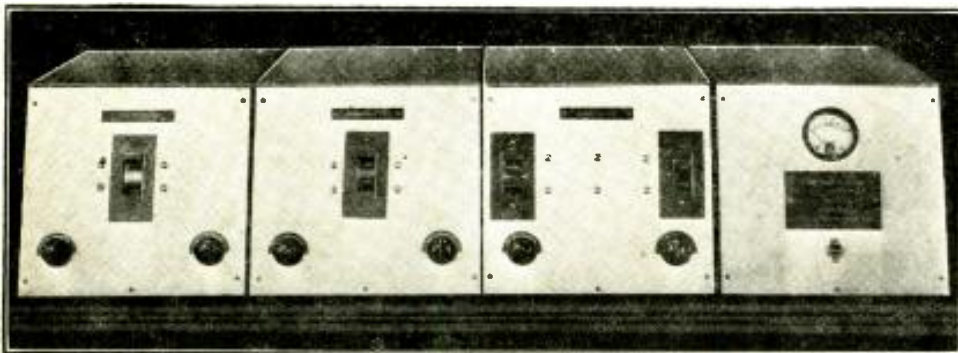

The model "C" Leutz short-wave receiver de luxe is illustrated above, from the front and from above, with shield box lids raised, at the right. Plug-in coils to cover the various wavebands are available—a handsome and extremely efficient short-wave receiver.

WE usually think of short-wave radio as belonging to commercial communications, marine, airplane and railroad radio; and so it has been, in the past. For which reason short-wave receivers have been far from good-looking, and were designed primarily for "dot-dash" work.

But, now that short waves are coming into their own for broadcast purposes, we find sets built for beauty and tonal quality as well as for distance. Such sets are the two new receivers here illus-

*Manufactured by Leutz Radiovision Corporation.

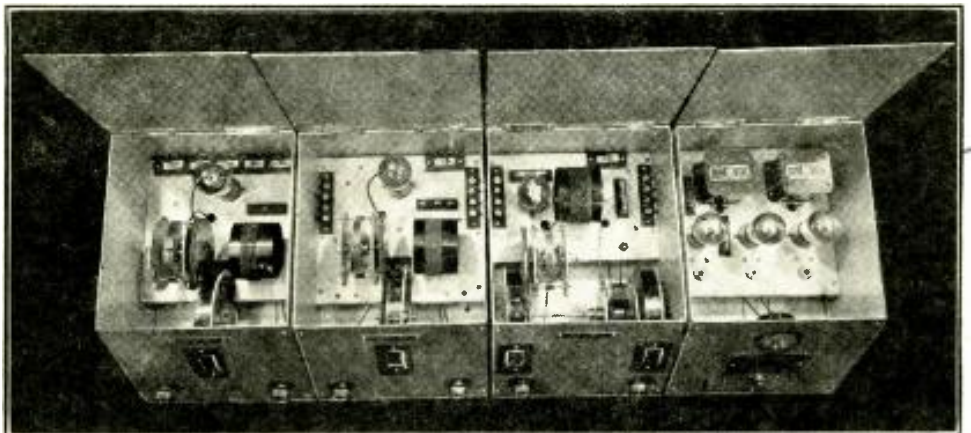

These two receivers, "Model C" and "Model L," are of unit construction, and resemble in appearance the famous Leutz "Transoceanic Silver Ghost," pre-

mier long-wave receiver. The short-wave receivers, however, are not quite as lengthy, having at most only four units; whereas the "Silver Ghost," when all the units are assembled, comprises six.

Flexibility Afforded by Unit Construction

The unit form of construction allows extreme flexibility. The units comprising the detector and the audio stages may be combined to form the receiver; if greater volume is desired, one or both of the R. F. stages may be added. And then, again (though this seldom hap-

pens), if anything should go wrong with the set, only the ailing unit need be returned for repair, instead of the entire receiver. Should that unit be one of

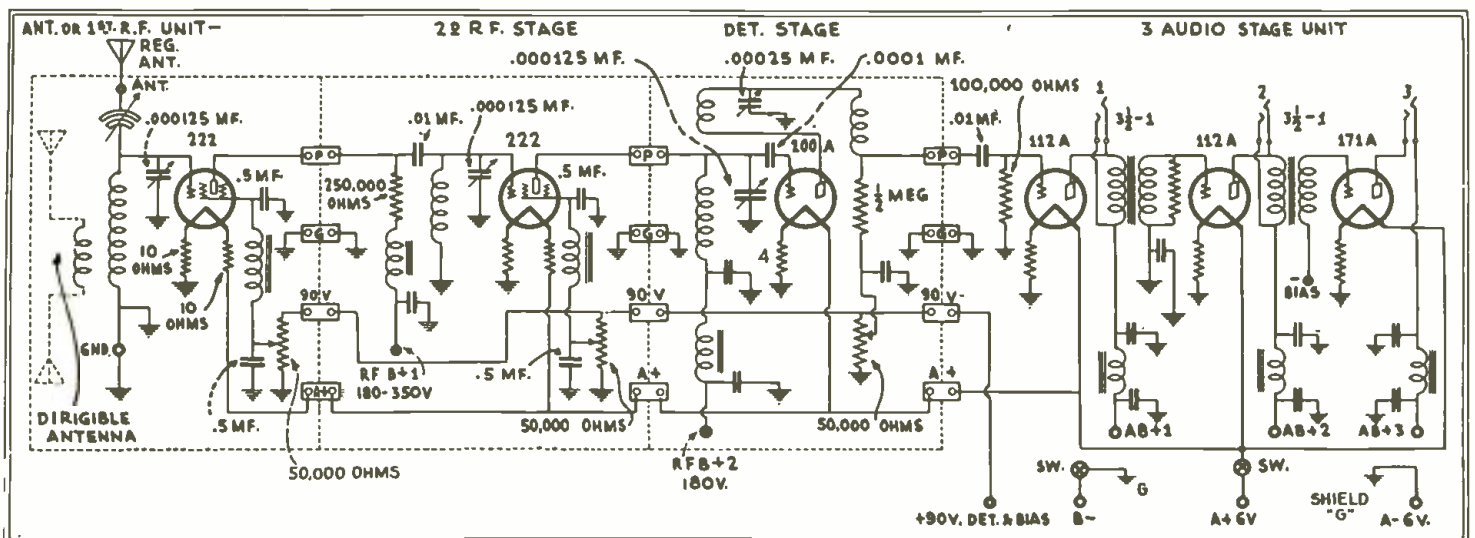

Complete wiring diagram of the Leutz short-wave receiver; three stages of audio amplification are used.

the R. F. stages, the set owner may still hear his radio programs, minus one of the units.

However, the real reason why Leutz resorted to unit construction is that it affords perfect shielding, so important to high-frequency radio reception. Since every unit is encased in an aluminum compartment, double shielding exists between each pair of units. Then, too, the compartments are extremely handsome, with their sloping fronts and the black plates contrasting with the aluminum cases.

Single Dial Tuning

At first thought it might be supposed that the unit form of construction necessitates separate tuning of each unit; but such is not the case. Rods, running through the cabinets, connect the dials and permit single-dial tuning. Of course, the dials must be matched; and, to obtain more accurate calibration the full circumference of the dial has been used. The mechanical action of the dial and the condenser is in the ratio of one to two, allowing vernier adjustment of each condenser.

Most adapters gain width of wavelength range by using a few coils and a relatively large tuning condenser, though vacuum tubes, being voltage-operated devices, require in a tuned cir-

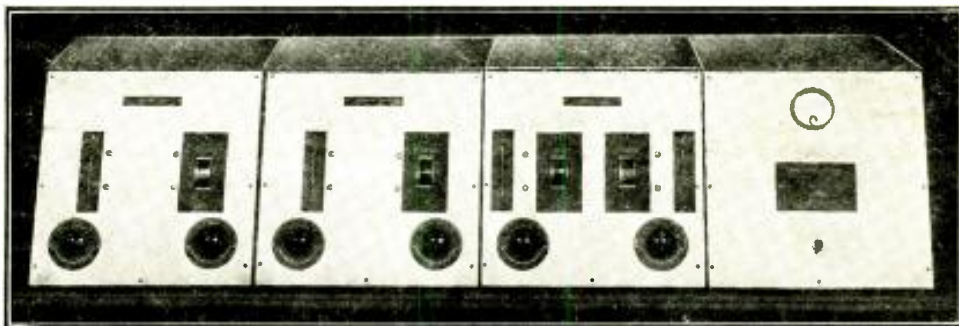

Front view of the model "L" short-wave receiver designed by Mr. Leutz.

by Leutz in his "Models C and L" short-wave receivers; even though the manufacturing cost of this method is higher than that of the usual method. However, Leutz has always preferred to work toward perfection rather than toward a price; with the obvious result that his receivers, though a bit costly, perhaps, give the finest performance.

The large inductance and the small tuning condenser make the receiver useless for ordinary broadcast wavelengths; but the degree of efficiency on the low waves cannot be matched in any ordinary receiver. Nor is this specialization a great handicap; since practically all who would have a "Model C" or a "Model L" short-wave set are already owners of fine long-wave receivers.

frequency currents to their proper paths.

Regenerative amplification in the detector stage, sufficient to properly operate the powerful audio amplifier, is obtained by using two tuned radio-frequency stages ahead of the detector. The reason why no push-pull amplifier is used is that it requires greater signal strength than can be conveniently obtained. In fact, half the satisfaction of short-wave work is to be able to push some very weak signal through the loud speaker. The sensitive cascade amplifier assures sufficient loud-speaker volume, while the extremely high quality transformers used make for absolute fidelity in tonal reproduction.

Both models of short-wave receivers are equipped with double-range voltmeters, reading from 0 to 8 and from 0 to 200. The meter is not permanently attached to the receiver, since such procedure would cause interference of the leads; however, flexible leads and test points enable the operator to take voltage readings of the various "A," "B" and "C" circuits throughout the receiver.

The chief difference between these two models is that the "Model L" has more shielding space. Both receivers have double shielding, but in the "Model L" the transformers are further away from the compartments. This greater protection increases the over-all amplification of the receiver and its sensitivity approximately 25 per cent, and gives correspondingly greater loud-speaker output. In addition, this model has a more elaborate system of dial control, and the components are somewhat more expensive.

Neither of the receivers is listed with coils; since different sets may be desired. The coils may be obtained separately, to cover any desired bands or wide wavelength ranges.

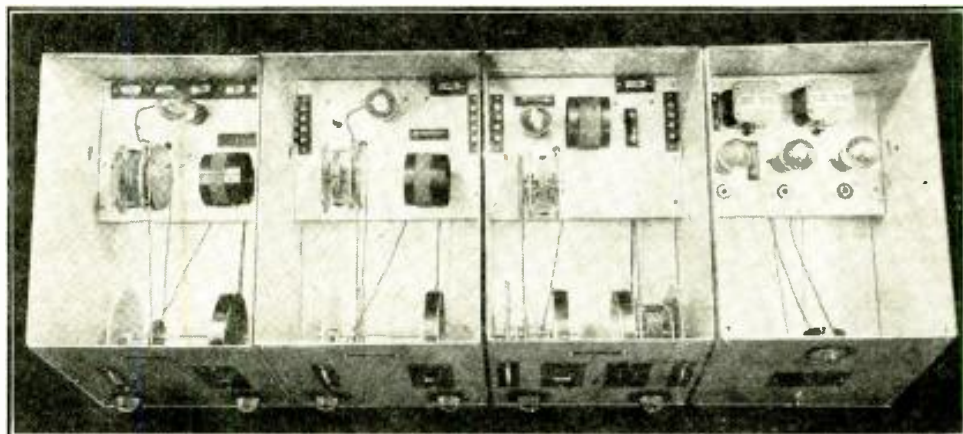

Looking down into the model "L" Leutz short-wave receiver—this model differs from the model "C" in that the coils are separated farther from the shielding, which raises its sensitivity and over-all amplification about 25 per cent, with resulting greater loud-speaker volume.

cuit a maximum of inductance and a relatively small condenser. The latter, the surest way of obtaining maximum and uniform efficiency over the entire wide frequency range, has been employed

In addition to the most complete shielding between the tuned radio circuits, all the circuits are provided with an elaborate system of chokes and by-pass condensers for the confinement of the radio-

G 5 S W Broadcasting On 11.55 Meters

THE British Empire Broadcasting is indeed the dream of every English radio enthusiast, which is easily comprehensible in view of the size of the British Empire. But although a full year has passed, since people began to occupy themselves with this idea, there will be a while yet before it is realized.

The greatest hopes were put in the short-wave transmitter, G 5 S W in

Chelmsford, which operates on a wavelength of 25.53 meters. Not only is it heard in Germany, but also occasionally in Australia and New Zealand.

But in spite of all the efforts made, it has not as yet been possible to find the ways and means of making daily reception in British India reasonably possible. Therefore complaints constantly come in from all parts of the empire,

about the bad reception of G 5 S W, and it is also remarked that almost all the short-wave stations can be heard except the British one. In India one can hear the German broadcasting station very well and also the Dutch stations, of course. Even Stockholm and Manila are heard decidedly better than Chelmsford. At present the experiments are being very irregularly carried on at 11.55 meters.

The Short Wave Aerial

and R. F. Transmission Line

By C. H. W. NASON

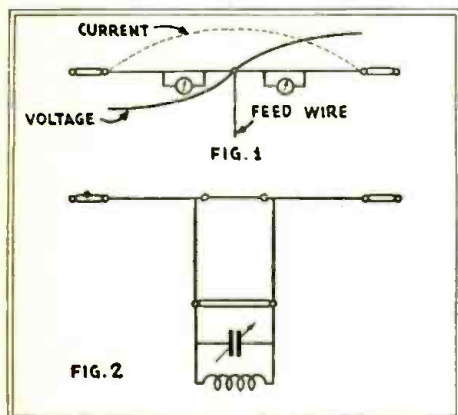

Fig. 1. Voltage and current distribution in a Hertzian radiator at its fundamental frequency.

Fig. 2. Arrangement of typical, two-wire short-wave antenna.

The short-wave antenna is a subject which most writers on short-wave phenomena say very little about. The editors have found that there is a great deal of misinformation entertained by many short-wave operators with regard to the antenna, and so they have asked Mr. Nason, well-known radio engineer, to present this special article.

With this in mind, we will deal with this type of antenna, and with a logical and efficient transmission line for feeding it from a distant point.

The fundamental of the Hertzian antenna in meters is its length in meters, multiplied by the factor 2.1. In kilocycles, this will be the natural wave-

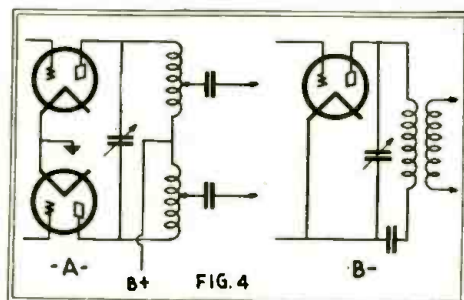

Fig. 4. Direct connection (A) and transformer coupling (B) of the radio-frequency transmission line.

length in meters (as found by the first formula) divided into 300,000. This figure is a fairly rough approximation, and the actual working frequency for maximum efficiency must be ascertained during the process of adjustment. The method of determining the true fundamental is as follows:

Two Meters Needed to Adjust Aerial Properly

It has been the usual practice to place a single meter at the center of the antenna and adjust for maximum current. This is based on an entirely fallacious premise; for there are possible distribution patterns wherein the current will be at a maximum at the center of the antenna, but the distribution to either side will be far from uniform.

For this reason, the preliminary determination of the fundamental frequency should be carried out with two ammeters

so arranged as to shunt a small portion of the antenna, as shown in Fig. 1. With the feeder wire terminating at the center of the radiator, the frequency should be adjusted until the current readings are identical; the meters need not necessarily be a permanent part of the installation. The dotted line indicates the current distribution and the full line, the voltage.

You will note that, in the figure, a single feed wire is shown. The single-wire transmission line has the advantage of simplicity of construction, and it is quite as efficient, when the terminal impedance is correctly adjusted, as the two-wire line. There exists also the advantage of cheapness; since no impedance-matching network or transformer is required.

Where to Connect Feeder to Antenna

While it was impossible to obtain correct results by striving for maximum current at the center of the antenna, when adjusting the frequency, this method is quite effective in obtaining the correct matching of impedance. The latter adjustment is attained by varying the position of the feeder as it is attached to the antenna. If the point at which the antenna and feeder are joined is varied, until maximum current at the center of the radiator is attained, the transmission line may be explored with an ammeter (arranged on a rider, as suggested before) so that we may verify the fact that standing waves are absent on the feeder, by checking the current distribution along its length. No diagram is necessary to illustrate the fact that, with the adjustment properly accomplished, the current distribution in the radiator will be as shown in Fig. 1;

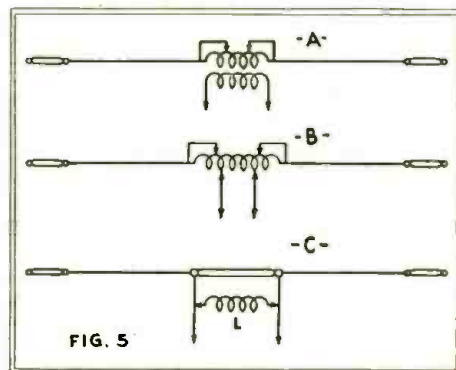

Fig. 5. Various methods of matching the impedance of the Hertzian radiator to a radio frequency transmission line.

IF we are to attain the maximum possible flexibility in the operation of a short-wave antenna system, it will be, in most cases, necessary that some form of transmission line be employed. There is no great obscurity surrounding the design and adjustment of such a system, but certain well-defined rules must be followed if maximum results are to be attained. The facts, as expressed in classical theory, remain the same whether the transmission line be employed in commercial telephony or in high-frequency radio transmission. If the line is uniform, and "terminated" in its "characteristic impedance," no reflections or standing waves will result. This merely means that a transmission line of regular recurring characteristics so terminated is equivalent to an infinitely long uniform line. By uniform we mean that the distributed inductance, capacitance and resistance per unit section, does not vary throughout the length of the line. These requirements are quite feasible; but, if the radiation is to be from the antenna, entirely and efficiently, it is necessary that the condition regarding the line's terminating impedance be also fulfilled. Otherwise the radiation will emanate from the transmission line, and not as desired.

The Single Wire Hertzian Oscillator

Probably the most versatile of antennas is the single-wire Hertzian oscillator. This form of radiator is capable of orientation in any direction, and is amenable to all sorts of experimental work in connection with polarization, direction and reflection of the wave.

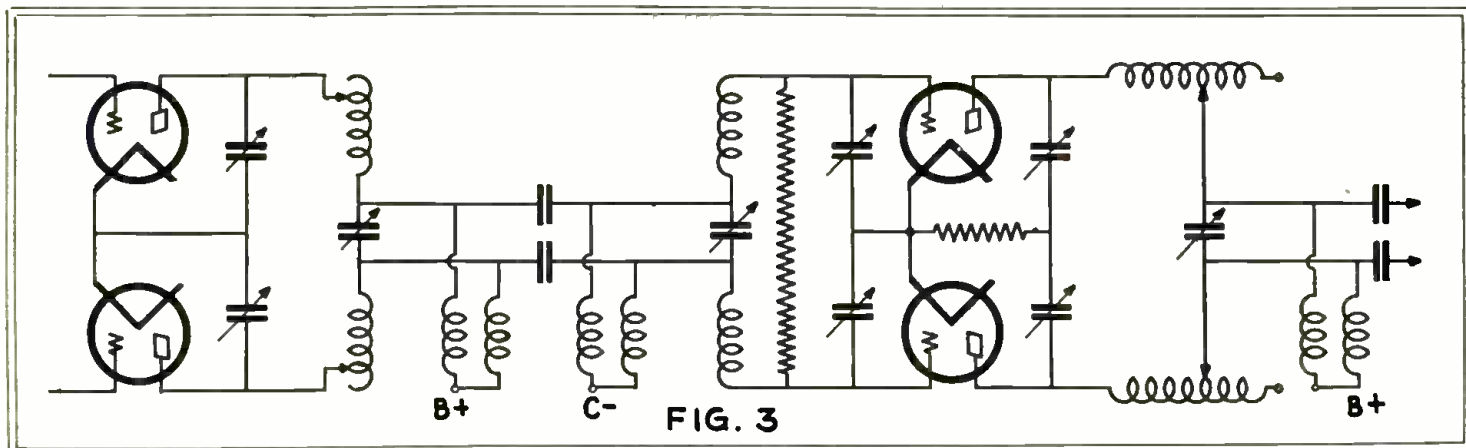

Fig. 3. Interstage and antenna line coupling arrangement, as employed in the Madrid-Buenos Aires telephone link.

and the current reading along the feeder will be constant in value. The system is known in amateur circles as "voltage feed."

In systems where two-wire transmission lines are employed, various methods of effecting impedance matching are applicable. Probably the simplest method is similar to that given above for the single-wire line. The two wires from the transmitter are attached directly to the radiator, and their positions adjusted for maximum current. This obviates the necessity for any coupling device to match impedances at the radiator. Although the final adjustment is a bit tricky, the simplicity of the arrangement, shown in Fig. 2, has much to recommend its use.

Other Uses for Transmission Lines

Transmission lines are used not only in coupling the transmitter to the antenna, but also in coupling between interstage circuits. A noteworthy example of such an instance is the case of the Spanish-South American telephone circuit, reported by C. E. Strong in *Electrical Communication*.

Fig. 3 shows a generalized R. F. amplifier for short-wave operation. The

coupling circuit, between two push-pull stages, and between the output stage and a 600-ohm antenna transmission line, are shown. The resistance, across the circuit in the input to the output stage, is for the purpose of damping out any variations in the input impedance of the tubes, due to their drawing grid current. The grid-circuit condenser across the line is adjusted to present an impedance of 600 ohms to the incoming line. The plate-circuit coupling condensers are adjusted to match the impedance of the amplifier tubes. Methods of calculation for such complex circuits are given in the appendix of *Transmission Circuits for Telephonic Communication*. Needless to say, with the antenna constants known, it is a simple matter to calculate the impedance-matching network for the antenna circuit. There are no limitations to the form of circuit employed; so long as the impedance match is consummated in such a manner that the power factor of the line is unity. Then there will be no reflection back along the line, and no radiation save in the antenna proper. Fig. 4 shows the arrangement for direct connection of the transmission line to the output stage, and for transformer coupling.

Coupling to the Radiator

The coupling at the radiator may be accomplished in as many modes—Fig. 5 at A, B and C shows applicable methods in addition to that of Fig. 2. The method indicated at C, Fig. 5, is that employed with certain of the Navy Department's directive antennas. The impedance match is secured by sliding a two- or three-turn "phasing coil" along the transmission line until the maximum field intensity in the proper direction is obtained. The system has been described by J. J. Lamb in the paper cited below.

Our attention has been given mainly to the method of feeding the Hertzian radiator, because of its extreme adaptability to modern usage and its ready operation on harmonic frequencies. It is hoped that, at some future date, the writer will be able to describe some of the directive antennas now in use, and give the reasons and means for their adaptation to amateur use.

BIBLIOGRAPHY

- K. S. Johnson: *Transmission Circuits for Telephonic Communication*. (D. Van Nostrand.)
- Everitt and Byrne: *Proc. I. R. E.*, Vol. 17—No. 10.
- J. J. Lamb: *Q. S. T.*, April, 1930.

Radio Etiquette

We reprint the following from the *New York Daily Investment News* by Mr. John Read. We are certain our readers will take it to heart.

John Z. Adams, as everybody in Wall Street knows, has made the stock brokerage business his avocation for the past fifty years. He spends his days in the offices of Schuyler, Chadwick & Burnham, but his real vocation is radio experting. John knows more about resistances and volts and screen grids and other such gadgets than the General Electric Company. He sits in the evening to listen to some station in Burma as casually as you and I tune in on WJZ.

Several weeks ago he enjoyed a program of Station NRH, whose home town is Heredia, Costa Rica. John immediately wrote a postal to tell the station he had received its program in Mount Vernon,

N. Y., and asked that he be sent a few facts regarding the station, such as its hours of broadcasting, number of watts and so on.

* * *

Recently John received the following letter from Amando Cespedes Marin, who apparently owns the station or something.

Amando Cespedes writes: "My dear Radio Fan, a post card is not always a thing to answer; it arrives by mail, unclean and looks cheap from the sender, and a radio mail station many times does not care to pay attention to same; moreover, when it mean that the sender did not have enough time or was afraid even to use INK, which is cheap and gently looking.

"I am telling you all of that because I appreciate all good words from 'my

listeners' BUT surely enough no one will get my certificate of reception which cost money, time and devotion, unless the inquire comes full of details and as a inspiration from the miracle of radio DX hearing.

"Thus you will have to write a letter and state what you heard or what you actually are listening from NRH, and your Diploma will be mailed at once on the assurance that same will give you more light and more devotion to radio activities besides entertaining you.

"A post card is a poor visiting card, or like if you were going to visit the Governor of your city with a poor suit of clothes. It all counts in this life and I want all my listeners to be decent with little NRH, the marvelous station working with 7½ watts only.

"(Signed) AMANDO CESPEDES MARIN."
(Continued on page 171)

Short-Wave Stations of the World

Kilo-Meters cycles
4.97-5.35 60,000-56,000—Amateur Telephony and Television.

- 8.57 35,000—W2XCU, Amherst, N. J.
- 11.55 25,960—G5SW, Chelmsford, England Experimental.
- 12.48 24,000—W6AQ, San Mateo, Calif. (Several experimental stations are authorized to operate on non-exclusive waves of a series, both above this and down to 4 meters.)
- 13.01 23,000—W2XAW, Schenectady, N. Y.
- 13.97 21,460—W2XAL, New York.
- 14.06 21,320—DIV, Nauen, Germany.
- 15.50 20,680—LSM, Monte Grande, Argentina, after 10:30 p. m. Telephony with Europe.
- FMB, Tamatave, Madagascar.
- PMB, Bandoeng, Java.
- 14.62 20,500—W9XF, Chicago, Ill. (WENR).
- 11.89 20,140—DGW, Nauen, Germany, 2 to 9 p. m. Telephony to Buenos Aires.
- 15.03 19,950—LSG, Monte Grande, Argentina, From 9 a. m. to 1 p. m. Telephony to Paris and Nauen (Berlin).
- D1H, Nauen, Germany.
- 15.07 19,900—Monte Grande, Argentina, 8-10 a. m.
- 15.10 19,850—WMI, Deal, N. J.
- SPU, Rio de Janeiro, Brazil.
- 15.12 19,830—FTD, Ste. Assise, France.
- 15.40 19,460—FZU, Tamatave, Madagascar.
- 15.45 19,400—FRO, FRE, Ste. Assise, France.
- 15.50 19,350—Nancy, France, 4 to 5 p. m.
- VK2ME, Sydney, Australia.
- 15.55 19,300—FTM, Ste. Assise, France, 10 a. m. to noon.
- 15.60 19,220—WNC, Deal, N. J.
- 15.85 18,920—XDA, Mexico City, Mex. 12:30 to 2:30 p. m.
- 15.94 18,820—PLE, Bandoeng, Java, Broadcasts Wed. 8:40 to 10:40 a. m. Telephony with Kootwijk (Amsterdam).
- 16.10 18,620—GBJ, Rodmin, England, Telephony with Montreal.
- 16.11 18,610—GBU, Rugby, England.
- 16.30 18,400—PCK, Kootwijk, Holland, Daily from 1 to 6:30 a. m.
- 16.35 18,350—WND, Deal Beach, N. J. Transatlantic telephony.
- 16.38 18,310—GBS, Rugby, England, Telephony with New York, General Postoffice, London.
- FZS, Saigon, Indo-China, 1 to 3 p. m. Sundays.
- 16.44 18,240—FTD, FTE, Ste. Assise, France.
- 16.50 18,170—CGA, Drummondville, Quebec, Canada, Telephony to England, Canadian Marconi Co.
- 16.54 18,130—GBW, Rugby, England.
- 16.57 18,120—GBK, Rugby, England.
- 16.61 18,050—KQJ, Hollnasa, Calif.
- 16.70 17,950—FZU, Tamatave, Madagascar.
- 16.80 17,850—PLF, Bandoeng, Java ("Radio Malabar"), Works with Holland.
- 16.82 17,830—PCV, Kootwijk, Holland, 3 to 9 a. m.
- 16.88 17,770—PHI, Huzer, Holland, Beam station to Dutch colonies. Broadcasts Mon., Wed., Thurs., Fri., Sat., 8:40-10:40 a. m. N. Y. Phillips Radio, Amsterdam.
- 16.90 17,750—HSIPJ, Bangkok, Siam, 7-9:30 a. m., 1-3 p. m. Sundays.
- 17.20 17,440—AGC, Nauen, Germany.
- 17.34 17,300—W2XK, Schenectady, N. Y. Tues., Thurs., Sat., 12 to 5 p. m. General Electric Co.
- W6KN, Oakland, Calif.
- W6AL, Oakland, Calif.
- W7XA, Portland, Ore.
- W7XC, Seattle, Wash.
- W2XCU, Ampere, N. J.
- W9XL, Anoka, Minn., and other experimental stations.
- 18.00 16,660—G2GN, S.S. "Olympic."
- G2IV, S.S. "Majestic."
- 18.40 16,300—PCV, Kootwijk, Holland, Works with Bandoeng from 7 a. m. Netherland State Telegraphs.
- WLO, Lawrence, N. J.
- 18.56 16,150—GBX, Rugby, England.
- 18.75 15,990—Salgon, Indo-China.
- 18.80 15,950—PLG, Bandoeng, Java, Afternoons.
- 18.50 15,375—FBBZ, French phone to G2GN.
- 19.56 15,340—W2XAD, Schenectady, N. Y. Broadcasts Sun. 2:30 to 5:40 p. m., Tues., Thurs. and Sat. noon to 5 p. m., Fri. 2 to 3 p. m.; besides relaying WGY's evening program on Mon., Wed., Fri. and Sat. evenings. General Electric Company.
- 19.60 15,200—OXY, Lyngby, Denmark, Experimental.
- 19.63 15,280—W2XE, Jamaica, N. Y.
- 19.66 15,250—W2XAL, New York, N. Y.
- 19.71 15,220—W8XF (KDKA) Pittsburgh, Pa. Tues., Thu., Sat., Sun., 8 a. m. to noon.
- 19.99 15,000—CM6XJ, Central Toluca, Cuba.
- LSJ, Monte Grande, Argentina.
- 20.00 14,990—TFZSH, Iceland.
- VK6AG, Perth, Australia.
- 20.80 14,420—VPD, Suva, Fiji Islands.
- 20.90 14,340—G2NM, Caterham, England, Sundays 5-6 a. m.; 12:30-2 p. m.
- 20.97-21.26 14,300-14,100—Amateur Telephony.
- 21.59 13,890—Mombasa, East Africa.
- 22.20 13,500—Vienna, Austria.
- 22.38 13,400—WND, Deal Beach, N. J. Transatlantic telephony.
- 22.97 13,050—W2XAA, Houlton, Me. Transatlantic telephony.
- 23.00 13,013—OBE, La Punta, Peru. Time Signals 2 p. m.
- 23.35 12,850—W2XO, Schenectady, N. Y. Antipodal program 9 p. m. Mon. to 3 a. m. Tues.; noon to 5 p. m. on Tues., Thurs. and Sat. General Electric Co.
- W6KN, Oakland, Calif.
- W2XCU, Ampere, N. J.
- W9XL, Anoka, Minn., and other experimental relay broadcasters.
- 23.98 12,500—G2GN, "Olympic," G2IV, "Majestic."
- 24.41 12,280—GBU, Rugby, England.
- 24.46 12,250—FTN, Ste. Assise (Paris) France, Works Buenos Aires, Indo-China and Java. On 9 a. m. to 1 p. m., and other hours.
- K1XR, Manila, P. I.
- GBX, Rugby, England.
- 24.63 12,180—Airplane.
- 24.68 12,150—GBS, Rugby, England, Transatlantic phone to Deal, N. J. (New York).
- FQO, FQE, Ste. Assise, France.

All Schedules Eastern Standard Time: Add 5 Hours for Greenwich Mean Time.

- 24.89 12,045—NAA, Arlington, Va. Time signals, 8:55-9 a. m., 9:55-10 p. m.
- 24.98 12,000—FZG, Saigon, Indo-China, Time Signals, 2-2:05 p. m.
- Oporto, Portugal.
- 25.10 11,945—KKQ, Hollnasa, Calif.
- 25.10 11,940—Tests of new Super-power broadcasters, Germany.
- 25.24 11,880—W8XK (KDKA) Pittsburgh, Pa. Tues., Thu., Sat., Sun., noon to 5 p. m., and Sat. night Arctic programs, Television Mon. and Fri. 2:30 p. m., 60 lines, 1200 r.p.m.
- W9XF, Chicago (WENR).
- W2XAL, New York (WRNY).
- 25.34 11,810—W2XE, Jamaica, New York (WABC).
- 25.36 11,820—K1XR, Manila, P. I., 7-11 a. m.
- 25.40 11,810—13RO, Rome, Italy (Tests)
- 25.42 11,800—U0RZ, Vienna, Austria, Tues., 9-11 a. m.; Wed., 5-7 p. m.; Thurs., 5-7 a. m.
- 25.53 11,750—G5SW, Chelmsford, England, 6:30-7:30 a. m. and 1-6 p. m. except Saturdays and Sundays.
- 25.60 11,690—CJRX, Winnipeg, Canada, 5:30 p. m. on till 8:30. Mon., Wed., Fri., 10:30 Tu.; 11:00 Thu.; midnight Sat. Sundays 11:30 a. m. to 1 p. m.; 10-11 p. m.
- 25.68 11,670—K1D, Kahulu, Hawaii.
- 26.00 11,530—CGA, Drummondville, Canada.
- 26.10 11,490—GBK, Rugby, England.
- 26.20 11,440—K1XR, Manila, P. I., 11:15-12:15 p. m., 2-4 a. m., 5-10 a. m.
- 26.22 11,435—DHC, Nauen, Germany.
- 26.70 11,230—WSBN, S.S. "Leviathan" and A. T. & T. telephone connection.
- IBDK, S.S. "Elettra," Marconi's yacht.
- 27.00 11,100—EATH, Vienna, Austria, Mon. and Thurs., 5:30 to 7 p. m.
- 27.75 10,800—PLN, Bandoeng, Java.
- BK, Rugby, England.
- 27.88 10,760—PLR, Bandoeng, Java, Works with Holland and France weekdays from 7 a. m.; sometimes after 9:30.
- 28.00 10,710—VAS, Glace Bay, N. S., Canada 5 a. m. to 2 p. m. Canadian Marconi Co.

(NOTE: This list is compiled from many sources, all of which are not in agreement, and which show greater or less discrepancies; in view of the fact that most schedules and many wavelengths are still in an experimental stage; that daylight time introduces confusion and that wavelengths are calculated differently in many schedules. In addition to this, one experimental station may operate on any of several wavelengths which are assigned to a group of stations in common. We shall be glad to receive later and more accurate information from broadcasters and other transmitting organizations, and from listeners who have authentic information as to calls, exact wavelengths and schedules. We cannot undertake to answer readers who inquire as to the identity of unknown stations heard, as that is a matter of guesswork; in addition to this, the harmonics of many local long-wave stations can be heard in a short-wave receiver.—EDITOR.)

- 28.50 10,510—RDRL, Leningrad, U.S.S.R. (Russia)
- VK2BL, Sydney, Australia.
- 28.80 10,410—VK2ME, Sydney, Australia, Irregular. On Wed. after 6 a. m. Amalgamated Wireless of Australia, Bennett Hills, N. S. W.
- KES, Hollnasa, Calif.
- 29.00 10,340—Paris, France, 1:30-3 p. m. daily; 9 a. m. Sundays.
- 28.86 10,390—GBX, Rugby, England.
- 29.50 10,160—HS2PJ, Bangkok, Siam, Sun., Tues., Fri., 8-11 p. m.
- 29.70 10,095—"Radio Experimental," Paris, France, From 5:45 p. m. daily; Sunday at 7 a. m. and 2 p. m.
- 29.98 10,000—CM2LA, Havana, Cuba.
- 30.15 9,940—GBU, Rugby, England.
- 30.20 9,930—W2XU, Long Island City, New York.
- Posen, Poland.
- 30.64 9,790—GBW, Rugby, England.
- 30.75 9,750—Agen, France, Tues. and Fri., 3 to 4:15 p. m.
- 30.90 9,700—NRR, Heredia, Costa Rica, 10:00 to 11:00 p. m. Amado Cespedes Marin, Apartado 40.
- W1XAZ, Springfield, Mass. Relays W1BZ.
- 31.10 9,610—7LO, Nairobi, Kenya, Africa, 11:00 a. m. to 2 p. m. Relays G5SW, Chelmsford, frequently from 2 to 3 p. m.
- Monte Grande, Argentina, works Nauen irregularly after 10:30 p. m.
- 31.23 9,600—LGN, Bergen, Norway.
- 31.26 9,590—PCI, Hllversum (Hindhoven) Holland, Thu., 1-3 p. m., 6-10 p. m., Friday 1-3 p. m., 7 p. m. to 1 a. m. Saturday, N. V. Phillips Radio.
- 31.29 9,580—VK2FC, Sydney, Australia, Irregularly after 4 a. m. N. S. W. Broadcasting Co.
- W3XAU, Lyberty, Pa., relays WCAU daily.
- VPD, Suva, Fiji Islands.
- 31.35 9,570—W1XAZ, Springfield, Mass. (W1BZ).
- 31.38 9,550—Karlswaterhausen, Germany, 10 to 11 a. m., 11:30 a. m. to 2:30 p. m., and 3 to 7:30 or 8:30 p. m. Relays Berlin.
- 31.48 9,530—W2XAF, Schenectady, New York, Mon., Tues., Thurs. and Sat. nights, relays WGY from 6 p. m. General Electric Co.
- W9XA, Denver, Colorado, Relays KOA.
- Helsingfors, Finland.
- 31.56 9,500—VK3LO, Melbourne, Australia, Irregular. Broadcasting Co. of Australia.
- O27RL, Copenhagen, Denmark, Around 7 p. m.
- 31.60 9,490—OXY, Lyngby, Denmark, Noon to 3 p. m.
- 31.65 9,480—Paris, France, 4 p. m. weekdays.
- 31.75 9,450—Rio de Janeiro, Brazil, 5-7 p. m. Testing 200 watts.

- 31.80 9,430—XDA, Mexico City, Mex.
- Posen, Poland, Tues. 1:45-4:45 p. m.; Thu. 1:30-8 p. m.
- 32.00 9,375—EH90C, Berne, Switzerland, 3-5:30 p. m.
- O27MK, Copenhagen, Denmark, Irregular after 7 p. m.
- 32.06 9,350—CM2MK, Havana, Cuba.
- 32.13 9,330—CGA, Drummondville, Canada.
- 32.40 9,250—GBK, Rugby, England.
- 32.50 9,230—FL, Paris, France (Eiffel Tower) Time signals 4:56 a. m. and 4:56 p. m.
- VK2BL, Sydney, Australia.
- 32.59 9,200—GBS, Rugby, England, Transatlantic phone.
- 32.80 9,110—SU, Mombasa, East Africa.
- 33.26 9,010—GBS, Rugby, England.
- 33.81 8,872—NPO, Cavite (Manila) Philippine Islands, Time signals 9:55-10 p. m.
- 34.50 8,690—W2XCU, Schenectady, New York.
- 34.68 8,650—W2XCU, Ampere, N. J.; W9XL, Chicago.
- W3XE, Baltimore, Md. 12:15-1:15 p. m., 10:15-11:15 p. m.
- W8XAG, Dayton, Ohio.
- W6KN, Oakland.
- W4XG, Miami, Fla.
- and other experimental stations.
- 34.74 8,630—WOO, Deal, N. J.
- 35.00 8,570—HKCI, Manizales, Colombia.
- RAGT, Khabarovsk, Siberia, 5-7:30 a. m.
- 35.02 8,560—G2GN, S.S. "Olympic."
- G2IV, S.S. "Majestic."
- 35.54 8,440—G2AA, shore-to-ship phone.
- 35.48 8,450—WSBN, S.S. "Leviathan."
- 36.00 8,330—3KAA, Leningrad, Russia, 2-6 a. m., Mon., Tues., Thurs., Fri.
- 36.74 8,160—EATH, Vienna, East Africa.
- 37.02 8,100—EATH, Vienna, Austria, Mon. and Thurs., 5:30 to 7 p. m.
- HS4P, Bangkok, Siam, Tues. and Fri. 8-11 a. m., 2-4 p. m. Tuesdays.
- 37.36 8,030—NAA, Arlington, Va. Time signals 8:55-9 a. m., 9:55-10 p. m.
- 37.43 8,015—Airplanes.
- 37.80 7,930—DDA, Doerbertz, Germany, I to 3 p. m. Reichpostzentralamt, Berlin.
- 7,890—VPD, Suva, Fiji Islands.
- 7,830—PCV, Kootwijk, Holland, after 9 a. m.
- 7,770—FTF, Ste. Assise, France.
- PCK, Kootwijk, Holland, 9 a. m. to 7 p. m.
- 7,550—S.S. "Bremer."
- 7,490—FTL, Ste. Assise.
- 7,500—TFZSH, Reykjavik, Iceland.
- EK4ZZZ, Danzig (Free State).
- 40.20 7,460—YR, Lyons, France, Daily except Sun., 10:30 to 1:30 a. m.
- 40.50 7,410—Eberswalde, Germany, Mo., Thu. 1-2 p. m.
- 41.00 7,310—Paris, France ("Radio Vitus") Tests.
- Moscow, USSR, 7-7:45 a. m.
- 41.46 7,230—DDA, Doerbertz, Germany.
- 41.50 7,220—HBSD, Zurich, Switzerland, 1st and 3rd Sundays at 7 a. m., 2 p. m.
- 41.70 7,190—VK6AG, Perth, West Australia, Between 5:30 and 10 a. m.
- 42.12 7,120—O27RL, Copenhagen, Denmark, Irregular. Around 7 p. m.
- 42.80 7,000—F6KR, Constantin, Algeria.
- 43.00 6,980—EAR 110, Madrid, Spain, Tues. and Sat., 5:30 to 7 p. m., Fri. 7 to 8 p. m.
- CTIA, Santos, Portugal, Friday, 4-5 p. m.
- 43.50 6,900—IMA, Rome, Italy, Sun., noon to 2:30 p. m.
- 43.60 6,875—FBMC, Catablanca, Morocco, Sun., Tues., Wed., Sat.
- D4AFF, Coethen, Germany, Sundays 4-6 a. m.; Tuesdays, Fridays, noon-2 p. m.; Thursdays 4-6 p. m.
- 43.84 6,840—VRY, Georgetown, British Guiana, Wed. and Sun., 7:15 to 10:15.
- 44.00 6,820—XC 51, San Lazaro, Mexico, 3 a. m. and 3 p. m.
- 45.00 6,600—Berlin, Germany.
- 45.20 6,635—WSBN, S.S. "Leviathan."
- 46.05 6,515—WOO, Deal, N. J.
- W4XG, Miami, Fla.
- 46.70 6,425—W2XCU, Ampere, N. J.; W9XL, Anoka, Minn.; and others.
- 47.00 6,380—CT3AG, Funchal, Madeira Island, Sat. after 10 p. m.
- VAS, Glace Bay, Canada, Tests.
- 47.35 6,335—W1DXZ, Airplane Television.
- VESAP, Drummondville, Canada.
- 6,215—FRT, Fort de France, Martinique.
- 6,205—LON, Buenos Aires, Argentina.
- 6,200—HKC, Bogota, Colombia.
- 48.74 6,155—W9XAL, Chicago, Ill. (WMAC) and Airplanes.
- 48.80 6,140—K1XR, Manila, P. I., 3-4:30, 5-9 or 10 a. m., 2-3 a. m. Sundays.
- 48.83 6,140—KDKA, East Pittsburgh, Pa. Tu., Thu., Sat., Sun., 5 p. m. to midnight.
- 48.96 6,120—Metala, Sweden, "Rundradio," 6:30-7 a. m.; 11-1:30 p. m. Holidays, 5 a. m.-5 p. m.
- ARI, Hongkong, China.
- 49.02 6,120—W2XE, New York City, Relays WABC, Atlantic Broadcasting Co.
- FL, Eiffel Tower, Paris, 5:30-5:45 a. m., 5:45-12:30, 4:15-4:45 p. m.
- HRR, Ponce, Puerto Rico, 9:15 p. m.-midnight, Mon., Wed., Fridays, From 11-12 p. m. Sat., Int. S. W. Club programs.
- 49.15 6,100—W3XL, Bound Brook, N. J. (WJZ, New York), 12 midnight on.
- 49.26 6,090—Copenhagen, Denmark.
- 6,080—W2XCX, Newark, N. J. Relays WOR.
- W9XAA, Chicago, Ill. (WCFL).
- VESGW, Bowman, Canada.
- 49.40 6,070—U0RZ, Vienna, Austria, 5-7 a. m., 5-7 p. m. Tues. and Sat., 9-10 a. m. Thu.
- 49.46 6,065—SAI, Metala, Sweden, 6:30-7 a. m., 11 a. m.-4:30 p. m.
- 49.50 6,060—W8XAL, Cincinnati, Ohio, Relays WIW.
- W9XU, Council Bluffs, Iowa, Relays KOIL.
- W3XAU, Lyberty, Pa., relays WCAU.
- HKC, Bogota, Colombia, 9:15-11:30 p. m., Monday to Friday.
- 49.67 6,040—W9XAO, Chicago, Ill. (WMAQ).
- 6,020—W9XF, Chicago, Ill.
- W2XAL, New York.
- W2XBR, New York, N. Y. (WBNY).

(Continued on page 174)

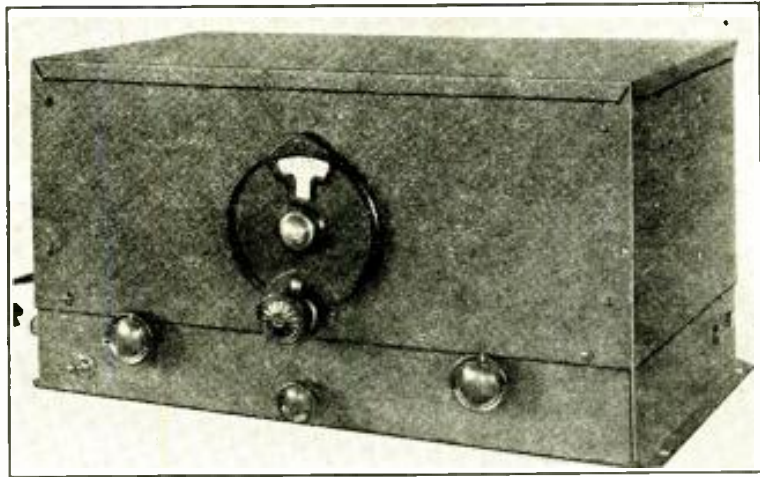

Front view of A.C. operated Silver-Marshall "Bearcat" short-wave receiver.

The
S-M "Bearcat"
 Shows
NEW FEATURES
 in
A. C. Operated
Short Wave Receivers

THIS short-wave receiver, fitted in a self-contained cabinet with a dark brown crackle finish, includes the power pack. The hum level in either the oscillating or non-oscillating state, with a pair of head phones in the speaker tip jacks, is remarkably low. It's a short-wave receiver that a "ham" will enjoy operating, because of its smoothness.

With this receiver it is possible to spread the crowded ham bands and secure close tuning on foreign phone stations, without dismantling the set, by using a little midget condenser that is built right into the circuit. To that unique feature has been added the increased amplification of the tuned radio frequency screen-grid stage and also the screen-grid first audio stage; still maintaining the convenience of single-dial operation. It uses, as well, a '27 type detector, '45 output, and '80 rectifier.

The "Bearcat" is built on a rugged steel chassis. It has one tuning dial with series antenna condenser and regenerative control, switch, and vernier.

The receiver can be purchased in kit form or completely wired. Plug-in coils are furnished, giving a range from 16.6 up to 200 meters.

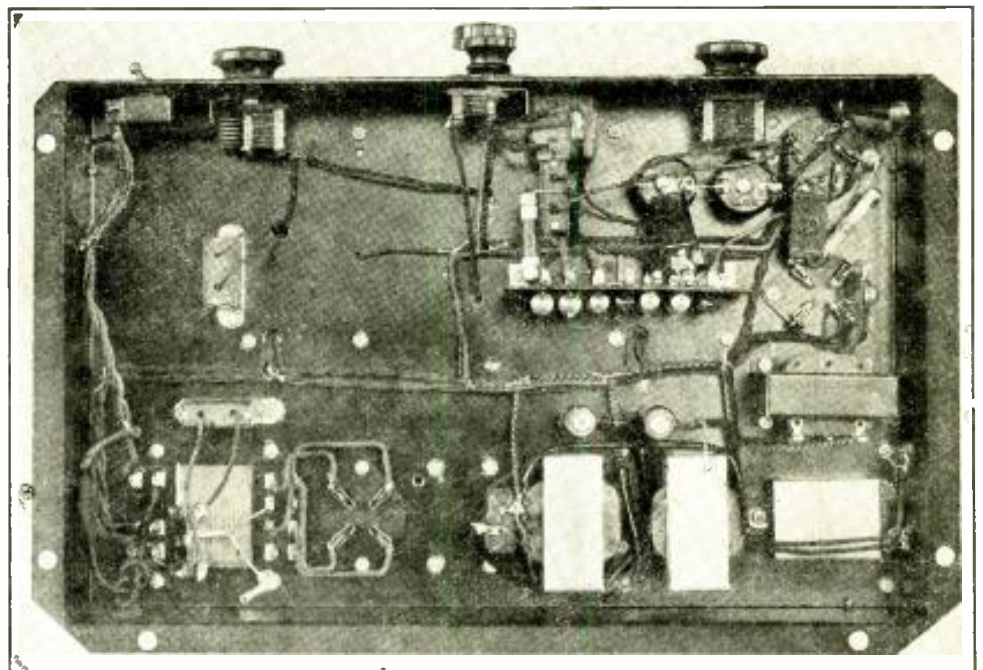

Bottom view of S-M "Bearcat" short-wave set.

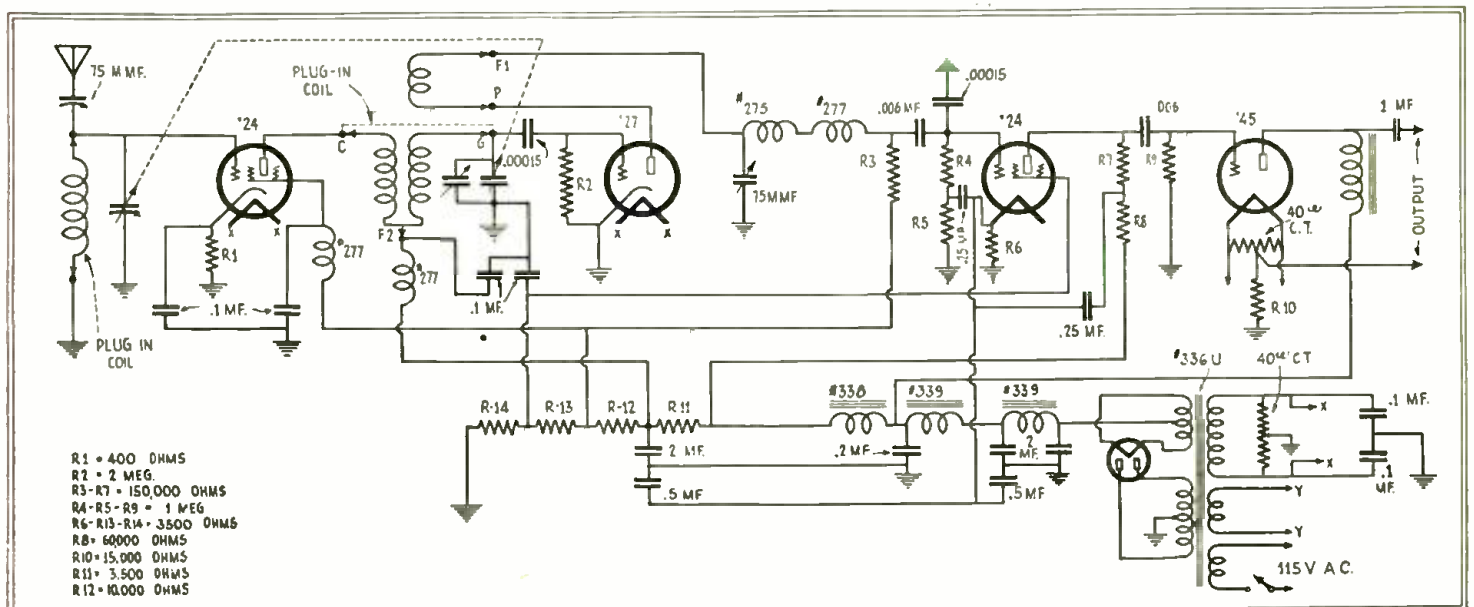

Wiring diagram of S-M "Bearcat" receiver for short waves. It employs a stage of shield grid radio frequency, regenerative detector and two stages of special audio frequency amplification.

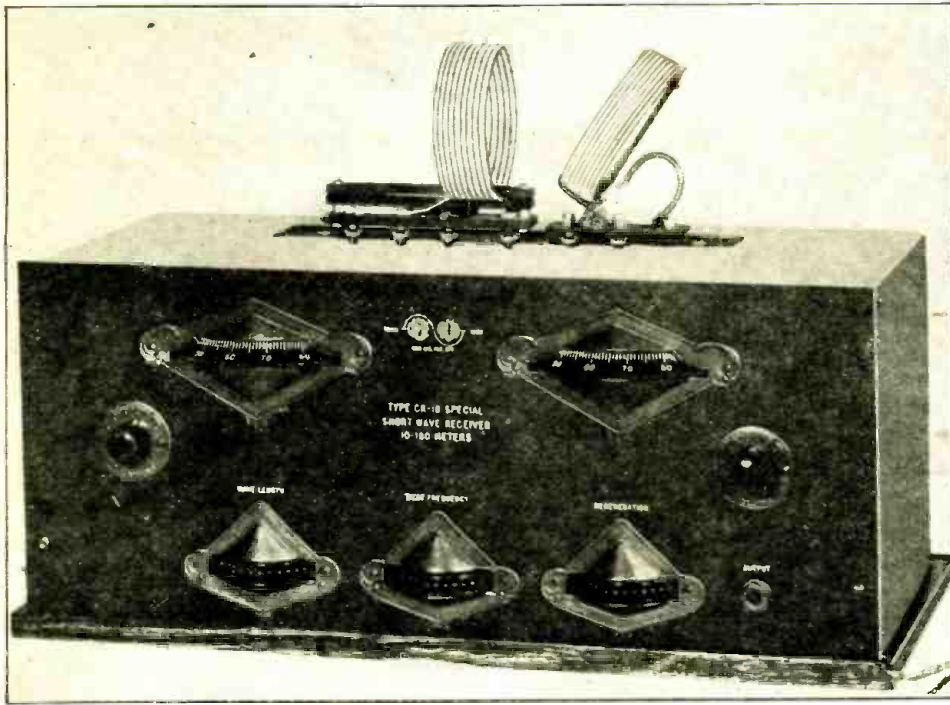

Handsome appearance of the Grebe Short Wave Receiving Set.

The GREBE Short Wave RECEIVER

This high quality short-wave receiver is battery operated. It employs '01A tubes in the regenerative detector and first audio stages and a '12A or '71A tube in the second audio stage.

THE "CR-18 Special" is a short-wave regenerative receiver with two stages of good quality audio amplification, suitable for broadcast and amateur reception over a range from 10 to 180 meters (30,000 to 1,600 kilocycles). This receiver is sufficiently sensitive to produce a satisfactory degree of volume from many distant broadcast stations. A very satisfactory volume control permits regulation of signal strength for headphone or speaker operation.

Installation and Accessories

The "CR-18 Special" is designed for battery supply. The detector and first audio tubes should be '01-A type and the second audio may be a '12-A or '71-A, depending on the use to which the receiver is put. The '12-A has a higher amplification factor and will give highest sensitivity for extreme distance; the '71-A will carry a much greater output.

For convenience in connecting, a color-coded cable is provided. When using the '12-A tube, 135 volts of "B" and 9 volts of "C" are recommended, and with the '71-A, 135 "B" and 27 "C,"

or 180 "B" and 40 "C" may be used. The heavy-duty type of "B" battery is recommended for the '71-A.

A "B" socket-power device is not recommended, even though the voltages may be adjusted to the specified values. One difficulty in using such a socket-power device with a regenerative detector is that a strong A.C. hum, or a growl, may be produced when the set is critically adjusted for maximum sensitivity; and the ease of operation may be impaired thereby.

Aerial

The antenna circuit of this set is untuned and therefore is adaptable to a wide variation in aerial length. If an outdoor aerial is used, from 75 to 100 feet over-all should be satisfactory. In many cases, as little as 20 feet of wire may be used as an outdoor or indoor aerial. The aerial should be erected in the most advantageous position possible, free and clear of surrounding objects, in order to get the maximum of signal strength. A good ground connection is essential for sensitive and stable operation of the set.

Operation

After the connections have been made, insert the No. 3 coil in the mounting; do not connect the antenna coil for the first adjustment. Plug the phones or speaker into the jack. Set the rheostat about half way and turn the volume control on full. Set the wavelength dial on zero, and, starting at zero on the regeneration dial, slowly increase the regeneration until a click or rushing sound (indicating oscillation) is heard in the phones. This point is subject to some variation, depending on the plate voltage, tubes, etc. If the dial is set five degrees higher than the point at which oscillations occur, the set should oscillate uniformly over the entire range covered by the tuning dial. An indication that the receiver is oscillating is obtained by touching the left-hand screw on the secondary coil, which will stop oscillation momentarily, with the characteristic click.

The antenna coil may now be inserted and the aerial connected. As the coupling coil is brought closer to the secondary, an increase of the regeneration dial

(Continued on page 172)

The Grebe receiver for short waves depends to a great extent, for its high efficiency, upon superior workmanship and quality of parts used. The regenerative hook-up employed is shown here.

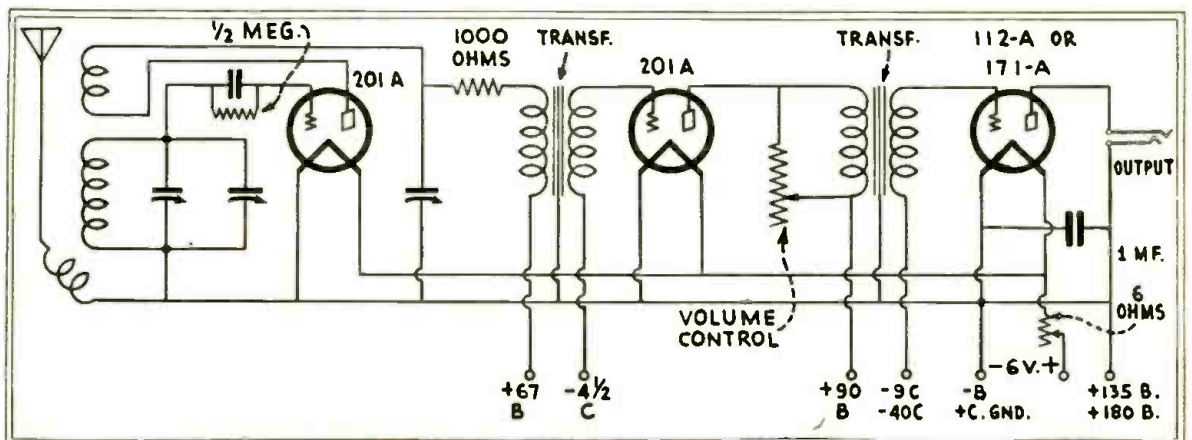

Ultra Short Waves

New Experiments in

Ultra-Short Wave Operation

THE study of ultra-short wave reception has led me to give up the method of modulation at the transmitter which I formerly favored especially—that of direct variation in the voltage on the grid. My reasons are as follows:

First, the wavelength of an ultra-short-wave transmitter is varied over a considerable range, by altering the grid bias.

Secondly, and especially in a powerful transmitter, when the grid voltage is changed, "breaking" phenomena may be seen; that is, the oscillatory energy increases and decreases jumpyly. Besides, the variation of the oscillatory energy, even when no actual "jumping" occurs, is by no means in proportion to the grid voltage. This causes, consequently, distorted modulation.

Changes of frequency, "breaking," and distortion are each sufficient to warrant us in seeking for an improved method. With very weak modulation and headphone reception, one does not observe these disadvantages so much, or may attribute them to the faults of the receiver; but if music is reproduced in the loud speaker, even a musically-untrained ear must notice certain faults.

The change of frequency by the alteration of the plate potential is less in degree than with a change of grid potential; but still it is always present, if there is no capacity in the oscillating circuit except that within the tube. If we reduce the self-inductance of the circuit, and compensate by adding capacity outside the tube, the frequency variation with changes in plate voltage will be lessened. "Breaking" is less liable to occur, and the change in the oscillatory energy is fairly proportionate to that of the plate potential. It is therefore advisable to use a modulating system which varies the voltage on the plate; or what is commonly called the Heising method.

Choice of Transmitting Circuits

As shown in Fig. 1, a choke is put in the plate lead, which is common to the transmitting and the modulating tube. It may be arranged as an auto-transformer, 1:1 ratio (Fig. 1a); as a step-up transformer (Fig. 1b), or as a step-down transformer (Fig. 1c).

Audio-frequency transformers are not especially suitable, on account of the high D.C. load; chokes used for house-current connections will serve.

By DR. ERNEST BUSSE

First Assistant in the Technical-Physical Institute of Jena (Germany)

The author gives some interesting data on the best methods for connecting ultra short-wave transmitters and receivers. The author prefers to modulate the transmitter by varying the voltage in the plate circuit instead of the grid; new receiver hook-ups are also given.

Another possibility is that of modulation by connecting two tubes in series, as in Fig. 2; but this is not to be recommended, because separate filament bat-

teries must be used. The modulator must be a tube whose emission is the same as that of the transmitting tube. With a modern "dull-emitter," a suitable grid bias will, in almost every case, improve the efficiency; and by this means the degree of modulation may be changed.

It has often been desirable to regulate the feedback by using the well-known cut-off or absorption circuit in the plate lead (Fig. 3), and it is sometimes advantageous to couple the antenna to this circuit.

For external control, which also serves to keep the frequency constant, the high frequencies at which we work require relatively large high-frequency power. In any case, the possibility of external control remains; and this, as well as frequency multiplication, I have successfully accomplished, down to a two-meter wavelength.

Some Receiver Problems

Some changes in the receiver circuits have also been made. The super-regenerative circuit, which in spite of many disadvantages gives the greatest sensitivity yet obtained, has been retained. Controlling the point of oscillation, by means of a second oscillatory circuit in the plate lead (a method abandoned in a combined transmitter and receiver), was again introduced. This works well also in the transmitter. (See Fig. 3.)

From the previous observations on transmitter modulation, it may be seen that it is more advantageous to change the plate voltage than the grid bias, in order to keep the receiver in resonance with the selected frequency. Otherwise, the signal will be received over the entire range of the receiver's tuning condenser, as a result of the alteration in frequency under grid-bias variation.

Problems yet awaiting solution include the comparison of the relative sensitivities on ultra-short waves, of the different receiving circuits, which would be very interesting.

But it is useless to maintain the superiority of any one circuit over another, if the former is the only one which we have used. Also, we must guard against results which are compared only mentally; as when we think that reception is stronger than it was a month before with different apparatus, different transmitting conditions, etc. It is best to rearrange the transmitter and receiver

(Continued on page 166)

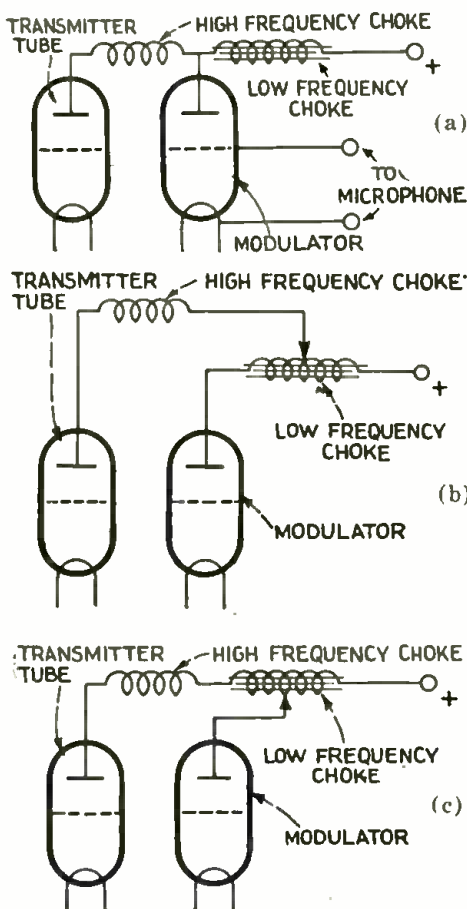

Fig. 1, a, b and c, respectively, show different ways of connecting choke coil in transmitter and modulator tube circuits.

Ultra Short Waves in MEDICINE

By DR. E. SCHLIEPHAKE*

THE rays of light and heat, at the upper end of their spectrum, merge with the Hertzian or radio waves. Among these, the band of very short waves has lately been given the

Short waves, particularly those of less than five meters in length, are rapidly coming to the fore in the medical world. Dr. Schliephake, one of the leading German authorities, gives us some vital and interesting facts on the latest medical experiments with short waves.

disturbances of the nervous system. Usually, there is first noticed a growing desire for sleep, which may increase to a high degree of enervation or prostration. Frequently, also, there is an in-

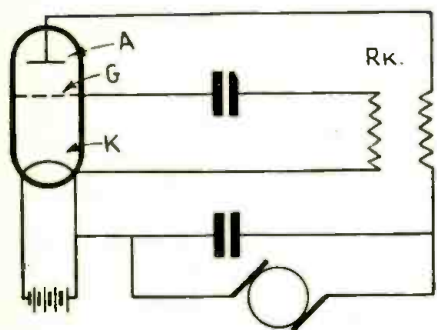

Fig. 1. Hook-up of a short-wave generator for medical purposes. The plate circuit is coupled to the grid, through the transformer RK.

name of "quasi-optical" waves, because these ultra-short waves are strikingly subject to the laws of optics. As Hertz formerly showed, they can be reflected by metal plane mirrors, and can be focused by concave mirrors. They are refracted by various mediums and can therefore be concentrated by lenses on a focal point.

Isolated experiments on the effects of such waves on living organisms have occasionally been undertaken; yet every fundamental investigation had to fail because of the comparative inefficiency of the transmitter used. Thus mice, which were exposed by Schereschewsky in a short-wave field, died after several hours; most quickly indeed at wavelengths of 15 meters.

The high-frequency processes hitherto used for medical purposes all work at much lower frequencies (the lower the frequency, *i.e.*, the number of oscillations per second, the longer the wavelength; and *vice versa*). The usual diathermic apparatus, in which low potentials are used with high amperage, give oscillation frequencies of about one million Hertz (cycles), equivalent to a 300-meter radio wave. With the D'Arsonval high-frequency apparatus, operating at very high potentials, the frequencies are lower; but they might, in very rare cases, go above 500,000 Hertz (600-meter wavelength).

Conducting all these high frequencies to the body is done by having at least one of the electrodes in immediate contact with the surface of the body. With apparatus operating at high potentials,

one electrode is usually in the form of a vacuum tube; in which case the electric current is generally transmitted to the body by the passage of sparks.

The great advantage of using very high frequencies lies in the fact that the treatment is made possible without any direct conduction of the current to the body.

Dr. Esau deserves the merit of having produced such ultra-short waves with sufficient power. The electron tubes used for this are similar to those used in radio.

The frequencies which can be attained are somewhat beyond 100,000,000 cycles, corresponding to a wavelength of 3 meters.

General Effect on Human Beings

In human beings who remain a long time in the field of radiation of such a transmitter, there appear gradually

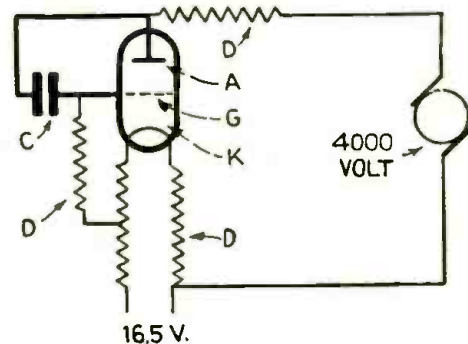

Fig. 2. Apparatus for producing ultra-short waves with capacitive feed-back: K, cathode; G, grid; A, plate; D, choke coils; C, condenser.

creasing nervous excitement. Repeated measurements of temperature give a slight increase in the bodily heat; which, however, is perceptible only after very long work at the transmitter and never amounts to more than half a degree. The effect of the waves can be increased by concentrating them with concave mirrors of an appropriate size. The person standing at the focal point then becomes an oscillator himself. According to my observations thus far made, the wavelength plays a part in the production of the phenomena described. In the three-meter field unpleasant sensations set in sooner, in general, than with waves of more than seven meters in length.

Use of the Condenser Field

A much more concentrated effect can be attained if, as Esau proposes, the subjects to be treated are placed in the capacitative field of a closed oscillatory circuit.

Then the total energy oscillating in the circuit must pass through an object which is placed as a dielectric between the two plates. The essential point in this process is, therefore, that no electric current is conducted to the object or organism in question; but merely the effect of the electric field (*i.e.*, the electric wave) is used, without requiring any contact with the conductors. Every object, or part of an object, placed in the electrostatic field acts like a smaller condenser.

The effect of such a condenser field on smaller animals is so powerful that they very soon die; mice in a few seconds, rats in fractions of a minute. As

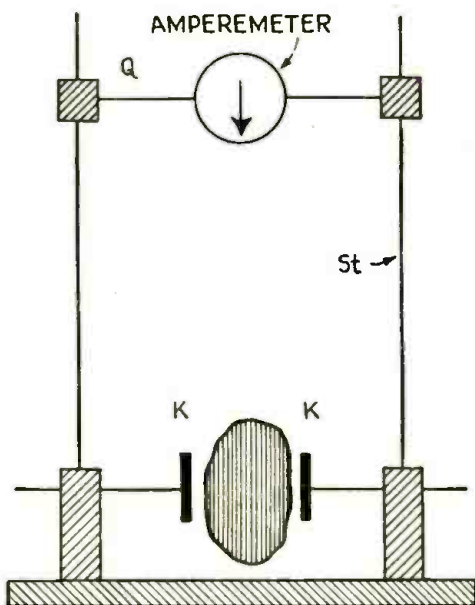

Fig. 3. The condenser field of a closed oscillatory circuit between the two condenser plates KK; St, supports; Q, movable connecting wire and ammeter.

*Instructor in Internal Medicine, University of Jena, Germany.

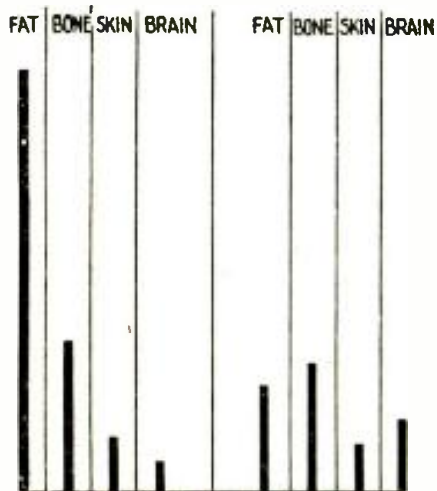

Fig. 4. Showing graphically the relative warmth produced in one minute, in different forms of human tissue, by diathermy (left) and in the 3-meter condenser field (right).

strated independently of me) limited almost exactly to the space lying between the condenser plates. Here all the individual parts, of whatever size and form, are subjected in equal manner to the effect of the field, the degree of heating being dependent only on the chemico-physical make-up of the object.

Thus it may be shown that, in diathermy of a bone, the heating of the marrow was not a tenth part of that of the skin; while in the case of the electrostatic field an equal, and even a greater, warmth can be attained inside the bone than on the skin. The relative penetration (the heating of deep parts in ratio to that of the surface) is, as I was furthermore able to prove, very essentially dependent on the distance of the condenser plates from the surface of the body, and their positions.

That the same relations hold also in the case of living beings was proved by measurements with thermo-elements in various orifices of the body. For example, Fig. 6 shows the rise in warmth in the stomach, in contrast to that produced by diathermal current; in the latter case, as much heat as could be

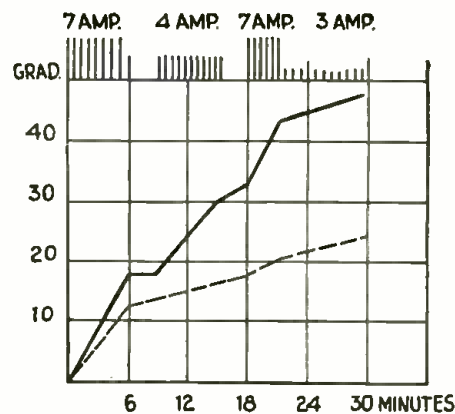

Fig. 5. This chart shows the rise in temperature in the underskin (dotted line) and in the heel bone (solid line) of a human foot when placed in a condenser field excited by a 4.5-meter wave. The vertical lines above the curves indicate the duration of the radiation in question; there was a rest period between the tests. ("Grad" means degrees.)

I was able to show, the bodily heat at the same time rises considerably, up to 109.4 degrees Fahrenheit and higher. Also I was able to prove that this heating in the electric field is principally a property of the electrolyte (in this case, the bodily fluids) and depends on its concentration; for every electrolyte there is a definite degree of dilution at which heating takes place most quickly. It is similar with the heating of certain colloids; in albumen solutions, however, molecular changes occur, without any particular rise in temperature.

In the case of bodily tissues which are exposed to the electric field, there are also very definite differences as to the rate of heating. Bones heat quickest in the field of the three-meter wave. The relative time response of the individual tissues is totally different from that obtained by the method of diathermy, the latter producing an especially strong heating of fat (Fig. 4). This explains why a great part of the diathermic high-frequency energy is absorbed in the fatty tissues just under the skin, and is thereby kept from the deeper-lying organs. Moreover, because of the strong heating of the skin thus produced, it is impossible to raise the applied amperage above a certain limit.

In exposure to the capacitive field, these difficulties are absent. The field effect is (as Heinrich also has demon-

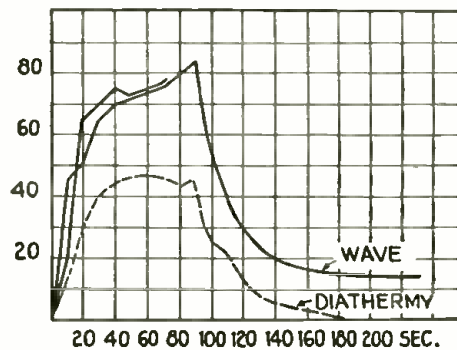

Fig. 6 shows various degrees of heat produced inside the stomach when acted upon by the condenser field (full line) and also by diathermy (dotted line). After ninety seconds the current was switched off; the temperature graduations are in 20ths of a degree.

borne by the skin was induced, while in the condenser field only a slight feeling of warmth set in.

The heating throughout of deep-seated organs is in itself an important healing factor, by reason of the consequent stronger flow of blood through them. It

was also to be assumed that micro-organisms, especially those causing illness, could be weakened by it. The experiments undertaken in this direction, both with bacteria cultures and with artificially-infected animals, have already given promising results, in which the specific effect of definite wavelengths on bacteria is notable.

Especially interesting may be the phenomena which were produced in the case of rabbits, by very localized radiation of the region of the spine. By this treatment the regulation of the bodily heat was disturbed; and, in fact, the nature of the disturbances could be graded by different strengths of radiation. After weak radiation, which results in no rise in bodily heat, there sets in after a few hours a fever lasting two or three days. If the radiation is carried through more strongly, the temperature often sinks afterward to 95 degrees Fahrenheit and lower; only to rise again after two or three days. Moreover, the bodily heat of animals so treated remains for a long time much more variable than in healthy ones. These animals, in which the temperature regulation was especially disturbed, almost all died, after three to eight weeks, from pneumonia and pleurisy. — *Die Umschau*.

To Think Fast, Heat Your Brain With Short Waves!

Ten years from now high-powered executives will be able to retire to thought chambers and there have their brain cells heated for fast thinking. Not only will they think faster, they will think better. They will decide the knotty problems of the world in practically no time at all. Or such is the opinion of O. H. Caldwell, radio authority.

In explaining this belief, Mr. Caldwell, who made his prophecy before the American Electrochemical Society recently, said that super-cogitation, induced through

the heat of the vacuum tube, would be quite an important weapon. Even the thoughts of minor human beings may be sharpened in the oven.

"In recent experiments in Germany," he declared, "the brains of living men and women have been gently heated internally by radio currents derived from high-frequency vacuum tubes, with the result of stimulating nervous reactions and thought processes, and causing improved mental speed and efficiency. While results are not yet conclusive, it appears

that extension of this method of electrically heating the brains of ordinary mortals may in future make men like gods.

"And it is not beyond conjecture that by 1940 big business offices may have special radio frequency 'thinking chambers' into which high-powered executives may retire when faced by particularly puzzling problems. Here for a few minutes they would undergo polarity reversals at the rate of 100,000,000 cycles per second to induce super-cogitation."

How to Build A SUPER-HET

By
R. WILLIAM TANNER
(W8AD)

When properly designed and built, the most selective short-wave receiving set is undoubtedly the super-heterodyne, as Mr. Tanner points out in his article. Complete details are given in this article for building an efficient short-wave super-het, which has actually been constructed and tested by Mr. Tanner. This "super" works on A.C.



Introducing Mr. Tanner

He started in the "radio game" in 1911. As soon as the government took the ban off Amateur activities, just after the World War, he built and operated one of the first Amateur radio telephone stations in the country. With this outfit he transmitted phonograph records; this was when old 8XK was an infant. Mr. Tanner designed and built many Amateur transmitting stations; originator of the Tanner audio system and the Tanner super short-wave converter. The World-Wide Super SW-6 is also another of his developments. Graduate of the National Radio Institute and has worked as a service man from Frisco to the "east coast." Has been writing for the radio press for more than three years and now has a "Lab" of his own where many new short-wave developments are in process.

THE number of broadcast stations operating in the so-called short-wave channels is on the increase; and the listening public, especially those with an experimental turn of mind, are becoming more and more interested. A great many short-wave receivers and adapters are being sold; the more important models using a stage of R. F. amplification, either tuned or untuned, ahead of a regenerative detector. While this gives a considerable gain in sensitivity, the selectivity is not all it should be. If provision is made to increase the selectivity by winding the R. F. transformers with relatively small primaries, sensitivity suffers. Another disadvantage of short-wave R. F. amplification is that the gain of the amplifier decreases with an increase in frequency; it is doubtful whether a gain factor greater than about four or five can be obtained below 50 meters. With such receivers, code stations 100 to 200 kilocycles away cause a great amount of interference.

It is logical to assume, then, that what is needed is a receiver capable of giving a high degree of selectivity. "But what degree of selectivity is necessary on the short waves?" some may ask. At the present time 20 to 25 kilocycles separation of stations is permissible. Once again a question may be asked: "What type of receiver will allow foreign broadcasting to be heard, with sufficient selectivity to cut out interfering stations?" There is one type of receiving circuit that is almost ideal from this standpoint; and that is the familiar Armstrong super-heterodyne, modified to conform with modern engineering principles. However, this type of receiver is rather complicated to build and is not to be recommended to the man who thinks in terms of one to four tubes. But for those placing no limit on the number of tubes, this is THE receiver.

A "Bread-Board" Model First Tried

Before going into the construction details, the writer wishes to say that the "super" about to be described was built up, and a great many "bugs" were eliminated, before this article was written. The parts were wired together on a wooden base, some fastened down and others left "floating." This was only an experimental model, and not pleasing to the eye; but the results obtained were amazing, to say the least. It was in operation only three days and nights; but during that time much sleep was lost playing around in the various bands. A goodly number of foreign broadcasters were heard, as well as many amateur radiophone stations.

Fig. 1 shows the complete schematic circuit of the "super" for A.C. operation. The first detector employs a '24 screen-grid tube, with a relatively low negative bias on the grid, since R. F.

interlocking of controls, an effect which causes much trouble in short-wave high-beat supers.

Band-Pass Filter Used

After the frequency-changing process, the output of the detector is fed to a two-stage, screen-grid, intermediate-frequency amplifier through a band-pass filter. Here the I. F. currents are amplified to a high degree, and then passed on to a '27 second detector, also of the grid-bias type. The I. F. transformers are designed for high gain, the band-pass filter giving the super the necessary degree of selectivity. Regeneration in the second detector, while not absolutely essential, is provided (this is a great help when tuning for real long-distance stations); a variable resistor, in series with the primary of the first audio transformer, is used for this purpose. Volume is controlled by varying the voltage on the screen grids of the I. F. tubes.

A two-stage, transformer-coupled audio amplifier, with a '27 in the first and a '45 in the last, brings the detected signals up to a value sufficient for all practical purposes.

A very useful addition, which should be incorporated in this circuit if the constructor is financially able, is a stage of untuned R. F. ahead of the first detector. The over-all gain in amplification will be substantially increased, and radiation of the oscillator energy entirely prevented—an important matter in locations where others may also use short-wave receivers.

A description of this efficient, high-quality, short wave super-heterodyne receiver follows:

First Detector Stage

The plug-in coils for the first detector are wound on Silver-Marshall "Type 130P" midget forms; the number of turns and the wire sizes are given in the table accompanying this article. The antenna coils L are wound in the slots. The turns on the grid coils L1 are spaced slightly for 20 and 40 meters; the two larger ones are close-wound. The top lead, nearest the flange, goes to the "G" prong on the form and the lower lead to "C." The antenna coils are connected with one lead to "C" and the other to "P." A variable condenser C, with a maximum capacity of .00014-mf., is employed for tuning. A small negative bias is applied to the grid through a 5,000-ohm resistor R, shunted by a 0.1-mf. by-pass condenser, C1, in the cathode lead. The screen-grid is furnished with a positive bias of approximately 22 volts, applied through the coupling coil L2 on the oscillator-coil form; practically all frequency-changer troubles are eliminated by this method. Care should be taken to connect the screen-grid by-pass condenser C1 to the

currents here are extremely small. This is preferable to grid-leak detection, because of the greater degree of selectivity obtainable. Four plug-in coils are provided to cover a range of 15 to 200 meters.

The oscillator uses a '27 tube in a shunt-feed Hartley circuit. Plug-in coils are also employed here. The R. F. energy is fed to the first detector by a coil connected in the detector screen-grid lead and coupled to the oscillator coil. This method practically eliminates

SHORT WAVE RECEIVER

correct side of L2; for otherwise no signals will be heard. The plate circuit contains a coil L5 and condenser C4, which are part of the band-pass filter; this will be detailed later under the subject of the I. F. amplifier.

The Oscillator

For the four plug-in coils used in the oscillator, also, specifications appear in the appended coil table; the tuning condenser C2 is exactly like that

suppress the harmonics, especially the second. It is suggested that the oscillator coils, condenser and tube be enclosed within a copper or aluminum shield can and located rather close to the first detector; so that the lead from L2 to the detector screen-grid will be short and direct.

In winding the coils, considerable care should be taken to see that the leads are soldered to the proper contact pins. The top lead of the grid coil goes to

wound for maximum gain, that is, with comparatively large primaries.

The band filter is composed of the tuned circuit L5, C4 in the output of the first detector, and another tuned circuit L6, C4 at the input of the first I. F. stage. These two circuits are critically coupled by means of a small, center-tapped coil BPF. This system is employed with excellent results in one of the most popular manufactured broadcast receivers on the market. Where the

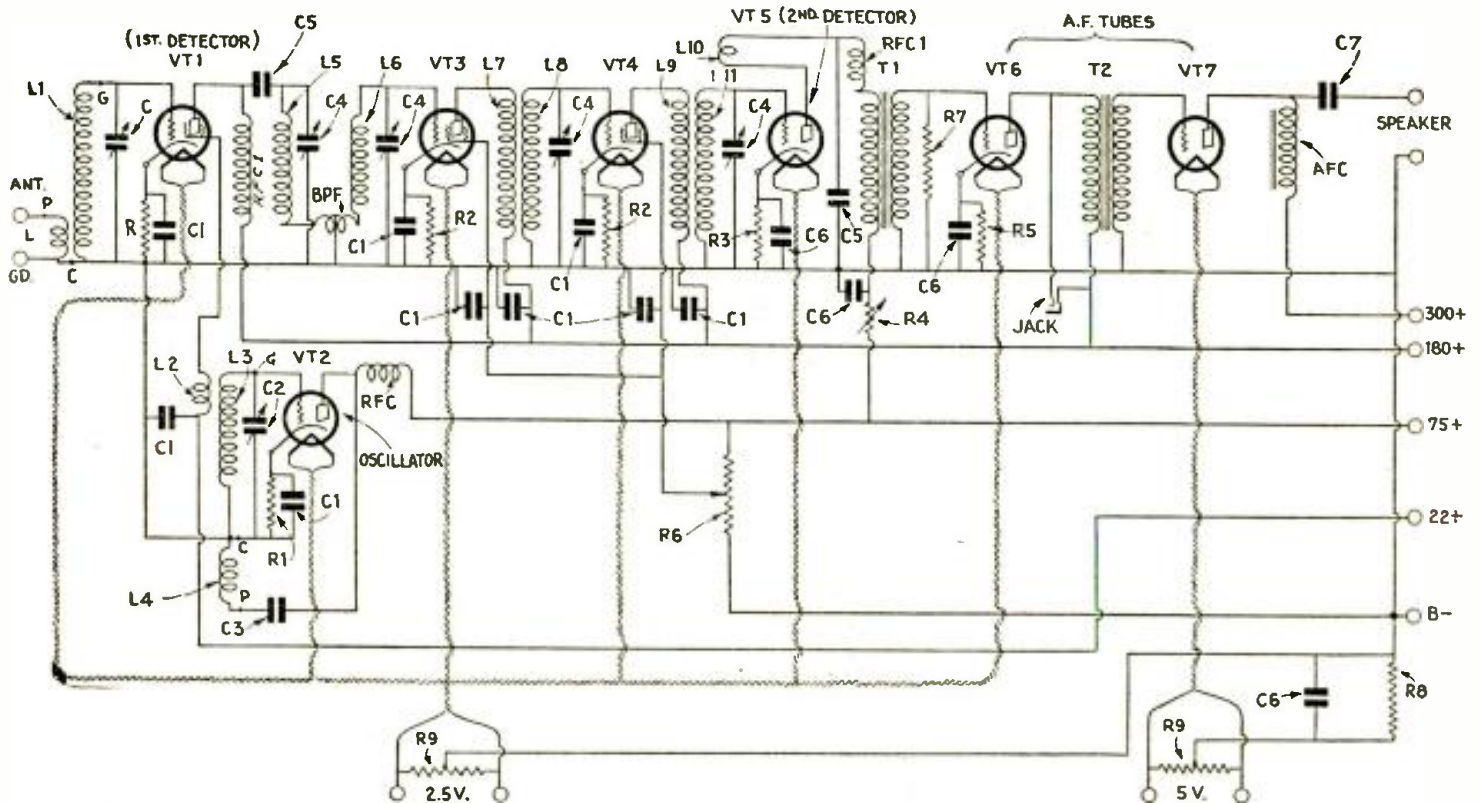

Super-heterodynes for "short-wave" reception are not so very common, for the good reason that we need a special design in order to make the set fairly simple in operation, due to the many tubes employed. Complete wiring diagram for Mr. Tanner's improved, short-wave super-het is given above.

in the first detector. To make the two dials "track" fairly close together, this condenser should be somewhat smaller when the high-beat frequency is employed. It would be interesting to experiment by removing one or two of the rotor plates; this depending, of course, upon the physical dimensions. The plate current is kept at a low value by biasing the grid. For this purpose, a 1,000-ohm resistor R1, by-passed with a 0.1-mf. condenser, is connected from "B—" to cathode. Condenser C3 has a capacity of .0005-mf.

The R. F. choke should be of a type designed for waves under 200 meters, and, in view of the characteristics of the circuit, must be capable of effectively blocking the R. F. currents throughout the entire tuning range. The plate voltage should be as low as practicable without reducing sensitivity, in order to

"G," the lower to "P," and the common lead of L3 and L4 to "C." The coupling coil is connected to the "F" prongs, and, since the turns are "scramble-wound" in the slot, polarity is of no consequence.

I. F. Amplifier

When designing this super, considerable thought was given to the best value of intermediate frequency to provide real selectivity, with a minimum of noise, and simplicity in transformer construction. Sensitivity was a secondary consideration. It was decided to employ a frequency of 500 to 550 kilocycles to give the quiet operation desired. This brought out the fact that something more than R. F. selectivity would be needed with only two I. F. stages; which indicated a band-pass filter arrangement of some sort. The transformers could then be

R. F. currents are of a low value, such a filter cannot be excelled.

Just a word to the more advanced experimenters: do not place a band filter of this type at the input of the second detector. Because of the relatively high currents handled, selectivity will be little or no better than if a straight transformer were used, unless the coupling coil BPF is reduced to a very few turns, resulting in low sensitivity. A filter at this point is a complicated affair and requires a great amount of care in construction.

Coils L5 and L6 are both wound alike; each consists of 200 turns of No. 30 enameled wire on 1 1/4-inch bakelite tube, 2 1/2 inches long. The BPF coil has 50 turns of the same wire, center-tapped, on a 3/4-inch wooden dowel, previously boiled in paraffine to exclude moisture.

The I. F. transformer located between the two screen-grid tubes has a secondary L8 with the same number of turns as L5 and L6. The primary L7 consists of 100 turns of No. 30 enameled wire, wound in a hank to a diameter that just fits inside of the bakelite tube, and coupled to the end of the secondary that

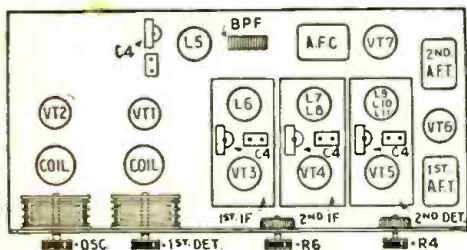

Fig. 2. Preferred arrangement of super-het parts on sub-panel.

will be connected to ground. A few "blobs" of collodion can be used to hold the primary in place. The leads of both windings are soldered to lugs, which are fastened to the form with short brass bolts.

The primary L9 and secondary L11 of the last transformer are exactly like those just described; an additional winding L10 is needed for regeneration. The design of the last is subject to quite a wide variation, due to the difference in heater-type tubes; however, 40 turns will generally be about right, with a plate voltage of 75 and a regeneration resistor R4 of 50,000 ohms.

The winding L10 is wound over the grounded end of the secondary L11, with a strip of paper between. The polarity is of great importance, the lead closest to the ground lead of the secondary going to the plate, and the other to "B+."

If the detector refuses to oscillate at the minimum value of R4, more turns are needed (providing the tickler is connected correctly as to polarity). If a loud audio howl is obtained when the resistance of R4 is reduced, turns should be removed. If present-day '27 tubes were more uniform in characteristics, the exact size of tickler could be specified.

The four tuned circuits are peaked to the same frequency, by means of .0001-mf. fixed and .0001-mf. midget condensers connected in parallel to form C4.

A negative bias is applied to the grids of the I. F. tubes by resistors R2, of 500 ohms, each in the cathode leads. Volume is controlled by a 50,000-ohm potentiometer R6 connected from 75 volts positive to "B-"; the contact arm leading to both screen grids. All the by-pass condensers C1 have a capacity of 0.1-mf.

The second detector receives its bias from a 25,000-ohm resistor R3 in the cathode lead, which is by-passed with a 1-mf. condenser, C6. A fixed .00015-mf. condenser, C5, by-passes the R. F. currents in the plate circuit to ground. The R. F. choke RFC1 should be one of a

type designed for operation above 600 meters.

In the original model, only the two I. F. stages and second detector were shielded. Small Silver-Marshall copper shield boxes (5½ inches high, 4½ inches long and 2¾ inches wide) are ideal for this purpose; such small sizes are necessary if the receiver is to be made compact.

Audio Amplifier

The audio amplifier is a conventional, two-stage, transformer-coupled affair employing a '27 tube VT6 in the first stage and a '45 VT7 in the second. Bias for the '27 is obtained from a 2,000-ohm resistor R5 in the cathode lead. Provision is made for headphone reception by connecting an open-circuit telephone jack across the primary of the second A. F. transformer.

Both transformers should be of the low-ratio type, and certainly not over 3 to 1. A 100,000-ohm resistor is connected across the secondary of the first transformer T1, to prevent what is known as "fringe howl." This will not always be needed; but, as the cost is small, it should be included, to be on the safe side.

A bias of 50 volts for the grid of the '45 is obtained through a 1,600-ohm resistor R8, connected from the center tap of the '45 filament resistor R9 to "B-." The output filter consists of a 30-henry, 50-ma. choke AFC and a 2-mf., 600-volt condenser C7.

Mounting and Wiring

In any short-wave receiver, the efficiency, shortness of leads, reduction of feed-backs, etc., should be considered before appearance; this means that the layout of the panel controls will, generally, not be pleasing to the eye. A suggested arrangement of parts is shown in Fig. 2. It will be noted that the two tuning condensers are located at the extreme left, with the volume and regeneration controls at the right; this allows symmetrical layout of the various stages. Because of the large variation in sizes and shapes of the many parts, no dimensions of the panel or baseboard will be given. After all of the parts are at hand, lay them out on a table in accordance with Fig. 2, but do not crowd them too closely. The size of the baseboard is then easily determined. The height of the panel will depend upon the cabinet, if one is to be used. Sub-panel brackets, 1 inch high, should be attached to the under side of the base, in order to provide space for the by-pass condensers, resistors and R. F. chokes.

It is a good plan, when wiring, to run all of the plate and grid wires first; then the "A," "B" and "C" wires can be placed wherever they fit in, without coming too close to the R. F. leads.

Adjustment and Operation

After your super-heterodyne is completed in every respect, testing may be started. All connections should be made and the filaments lighted. Plug a pair of headphones into the telephone jack

provided, and place the largest of the first detector and oscillator coils in their respective sockets. Set the second detector's tuning condenser C4 somewhere near its maximum capacity and, with the second detector in a non-oscillating condition, tune in a weak station (or harmonic), either radiophone or telegraph. Then adjust the first three I. F. tuning condensers for greatest signal strength. Now increase regeneration by reducing the resistance of R4, to determine whether the polarity of the tickler is correct. If oscillations cannot be obtained with R4 all of the way out, or if audio howling is bad, modification of L10 is necessary; the procedure is that explained in another section of this article.

The exact length of the best antenna to use will depend upon the degree of selectivity desired; even with the band-pass filter at the input of the I. F. amplifier, extremely loud signals will spread out over a comparatively wide band if a large antenna is employed. On the original model, with an antenna one foot long, many amateur radiophone stations east of Denver have been brought in (in Michigan) with very good audibility; and this is not to be considered freak reception, as it has been done a number of times. Using a length of No. 16 fixture wire 20 feet long, suspended close to the ceiling on the lower floor, G5SW has been picked up on two or three occasions.

Possible Improvements

There are a few improvements that can be incorporated in this super, and may sometimes be desirable; the first of these is the use of a '45 push-pull audio stage, in place of the single tube. It has been found that broadcasting from Pittsburgh and Schenectady can easily overload one power tube.

A much better arrangement for the telephone jack, also, is shown in Fig. 3.

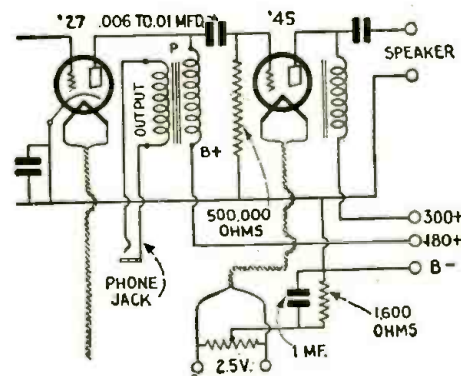
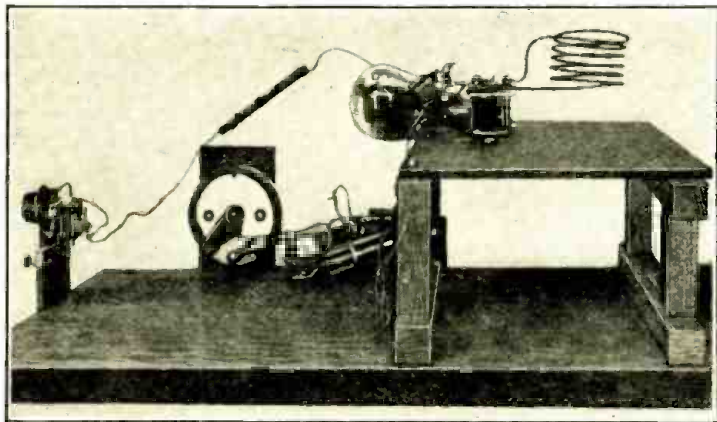

Fig. 3. Optional hook-up of phone jack in secondary circuit of transformer. The 1,600-ohm resistance supplies the bias for the '45 tube.

The transformer may be any one of reliable make; the primary is connected in the plate circuit of the '27 A. F. tube, in the usual manner, and the phone jack to the secondary. Quality with headphones will be much better, since no

(Continued on page 160)



An easily-constructed, low-power, ultra-high frequency oscillator suitable for tests at body frequency.

What Is The Wavelength of Your Body?

By A. BINNEWEG, JR.

Tuning at human frequencies—Unusual reflection and absorption results which occur at ultra-high frequencies

CONSIDERABLE publicity was given lately to the fact that the human body is "tuned" to a wavelength near 3 meters; which was discovered, and given first practical tests, at the University of California and was described by the writer for the first time in *Radio News*, then owned and edited by Hugo Gernsback, editor of **SHORT WAVE CRAFT**.

The average radio enthusiast does not understand the underlying principles giving rise to the interesting effects

and instructive facts have been discovered about the effects of the very high frequencies (or ultra-short wavelengths) on the human body.

Any conducting body has a natural electrical period of vibration, depending upon its inductance and its capacity. Hence, it is found that a wire, of any length, because of its inductance, and distributed capacity, has a natural period at which a maximum current can be induced in it from an oscillating source. This phenomenon is, in principle, similar to the action of a tuned circuit in any radio set. When the circuit is tuned exactly to the "exciting" frequency (incoming signal frequency), maximum response is obtained.

The Wire as an Absorption Circuit

The result is the same if the tuned circuit remains fixed in its electrical constants and the frequency is adjusted to resonance with it. It is found that, by adjusting the oscillator frequency to a wire's natural electrical frequency, a maximum response, or current, within the wire, is obtained.

These things will be better understood by referring to Fig. 1; in which, at A, is shown an ordinary sine-wave variation in either current or voltage. Whenever an oscillator passes through one electrical cycle, oscillatory energy is sent out in the form of a wave. Thus, one cycle corresponds to one wavelength on the diagram. The wavelength distance, of course, can be measured from any corresponding point of one wave to a

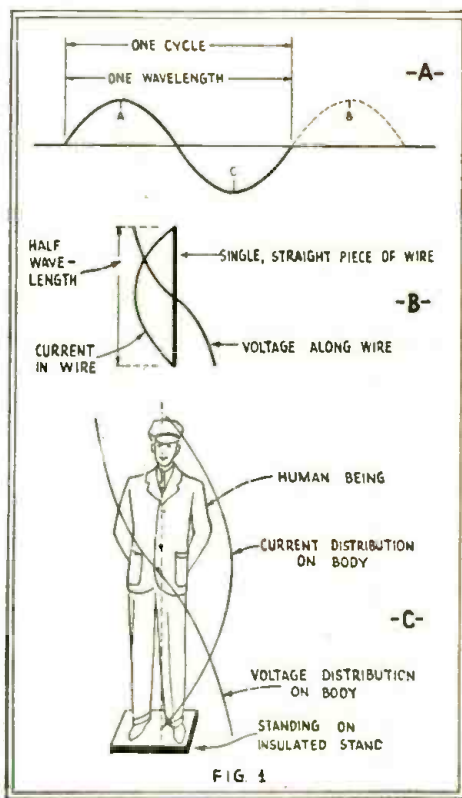

At "A" we see 1 cycle or 1 wavelength depicted; "B" shows the current and voltage relations in a single wire at its fundamental frequency; "C" shows these relations at human frequency.

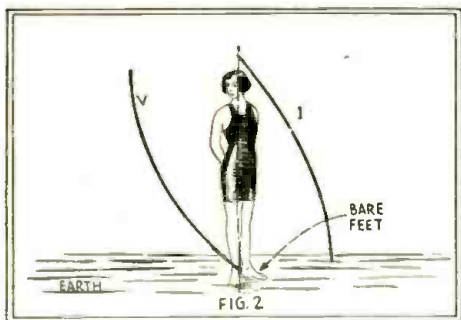

Current and voltage distributions on human body, if grounded.

which occur when one tunes an oscillator to the natural electrical frequency of the human body. The writer has received many requests for additional information regarding these interesting tests, which demonstrated that the human body can act as its own aerial, and even reflect radio waves which come into contact with it. Many other inter-

corresponding point on the next (for example, from A and B on the wave of Fig. 1A). The distance A to C, Fig. 1A, is half of one wavelength. This distance is important when considering resonance effects and "standing" waves on wires, and on the human body.

The fundamental wavelength of a wire is that at which half a wave of the exciting frequency is "standing" on it; that is, when the electrical length is such that half a wave just fits on the wire. Thus, if a wire has a definite length, and an ammeter is connected at its central point to serve as an indicator, it will be found that the maximum induced energy results when the oscillator is tuned to such a frequency that half a wave exists on the wire (B, Fig. 1).

(Continued on page 164)

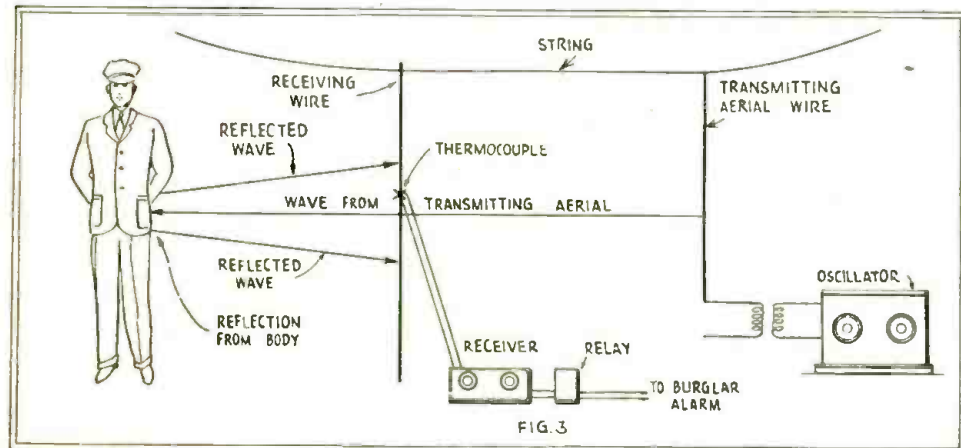

How waves are reflected by human body.

Short Wave Operation Hints

By

ROBERT HERTZBERG

“How and Why” of short-wave operation clearly explained by an expert. How to make the regeneration smooth over the whole dial; best connection of the tickler; what kind of chokes; how to select proper grid leak; what size by-pass condensers to use and many other problems explained for the beginner

MOST owners of short-wave receivers do not fully appreciate the fact that the entire success of their outfits depends on how smoothly and easily they can control the regenerative action of the detector tube. Many carefully and beautifully built receivers using the most expensive parts do not produce more than a few weak local broadcast stations and possibly a dozen loud telegraph stations, simply because the detectors collapse into oscillation with a pronounced “plop.” Many carelessly assembled sets using parts retrieved from the junk box bring in 'phone stations from all over the world, because the regenerative action is under nice control.

The question is, “How can the regenerative action be made smooth?”

Balancing the Regenerator

The problem is an easy one to solve, providing you have just a little patience. First of all, the size of the tickler must be just right. Most short wave plug-in coils are of such simple construction that turns of wire can be added or removed without difficulty. The idea is this:

Start off with the smallest coil. Turn the tuning condenser to 100, and start advancing the regeneration condenser (or variable resistor, if you are using this method of control). If the tickler is just the right size by some accident, the circuit will go into oscillation as the regeneration condenser reaches maximum capacity. If you find that you need only a fraction of the capacity, you can employ less tickler, and accordingly you should

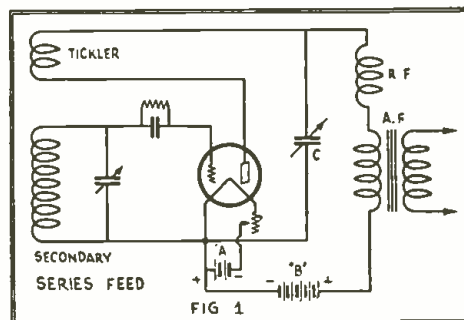

The recommended method for controlling regeneration, smoothly and without “dead spots.”

remove the coil and unwind one turn—but not more. One turn of wire on a small coil makes a lot of difference sometimes. Put the coil back and again experiment with the regeneration control. You will find that you now need more capacity.

With a little experimenting, you can strike just the right amount of tickler winding that will make the circuit oscillate with the regeneration condenser turned to about 90 or 95. Do not work too near 100, as you may have to raise the “B” voltage if the “A” battery should fall low sometime.

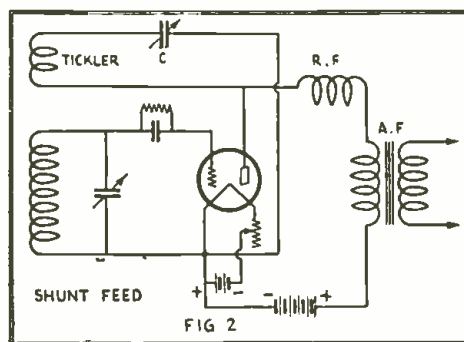

Until recently, this was the recommended connection for regeneration control.

As you turn the tuning condenser from 100 to 0, you will find that you need less and less of the regeneration condenser. The smallest possible size tickler for the highest wavelength setting of the coil will result in the smoothest regenerative action.

With a great many plug-in coils, the circuit will oscillate only up to 80 or 85 on the tuning dial. This indicates that the tickler is too small, but before adding wire to it, try a different detector tube, or raise the plate voltage a little.

If you are using an '00A, or an '01A, do not go above 45 volts, as they are difficult to control with higher “B” voltages. A voltage of 45 is about right.

Perform the same operation with all the other plug-in coils; of course if you have a set using a stage of tuned R.F. ahead of the detector, you don't have to touch the antenna coils, as these do not carry tickler windings.

Best Tickler Hookup

Incidentally, there is some question among short wave experimenters as to what is the best connection for the tickler. There are two possible arrangements, shown schematically in Figs. 1 and 2.

Fig. 1 shows the “series feed,” with the tickler connected in series with the plate circuit of the detector and with the regeneration condenser *C* between the top end of the tickler and the filament. A radio-frequency choke, *R.F.*, is usually included, but it is not always necessary, as many people have discovered.

Fig. 2 shows the “shunt feed” system, so called because the tick-

ler and its control condenser *C* are bridged across the plate circuit of the tube.

The writer has done considerable experimenting with short wave sets, having been particularly concerned with the development of an advanced receiver recently placed on the market, and always prefers the series feed. It is more reliable than the shunt feed scheme, because it is not dependent on the R.F. choke. With the series feed, the radio-frequency component of the plate current *must* go through the tickler, because it has no other path; therefore, the R.F. choke is more or less superfluous, although helpful if the first audio transformer has a primary winding of high self-capacity. With the shunt-feed, the R.F. component of the plate current is forced through the tickler only because it is kept out of the audio transformer by the R.F. choke. If the choke happens to have electrical "holes" in it, as many have, the R.F. is short-circuited by the self-capacity of the transformer primary, and hence there is no feed-back and no regeneration at those points.

Standard 3-circuit regenerative receiver for short wave reception, incorporating variable antenna coupling, variable detector "B," and smoother regeneration. The rotor of the regeneration condenser connects to the "A" circuit, to prevent hand capacity effect. For code reception, a cheap, high ratio A.F. transformer is best.

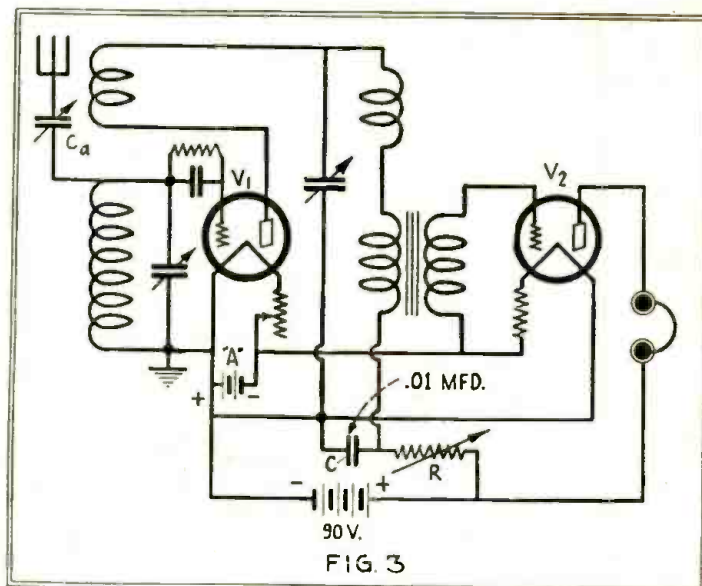

FIG. 3

Correct Grid Leak

The effects of the grid leak value and the "B" voltage applied to the detector have often been emphasized. It is easy enough to try different grid leaks, but not so very easy to change the battery voltage. Most "B" batteries have taps only for 22½ and 45 volts, and sometimes it is very evident from the operation of a set that some intermediate value would be very de-

The resistor should be of the so-called "universal range" type, with a resistance variation from about 40 ohms to 10,000,000. If there is already a separate "B" detector plate lead, insert the variable resistance in series with the wire, bringing the by-pass condenser from the "B" side of the transformer primary to the filament. If you are now building a short-wave receiver, you can save one battery lead and one binding post by simply connecting the resistor *R* to the same 90-volt tap feeding the audio tube or tubes. The resistor can be placed on the sub-panel; like the aerial coupling condenser *Ca*, it is left alone after being adjusted. Its best setting is quickly found with a little experimenting.

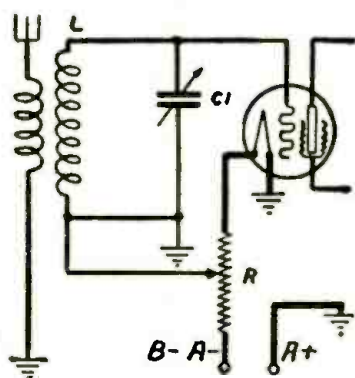

Fig. 4. Incorrect. Although this puts the rotor of the variable condenser at ground potential, it shorts the "A" supply.

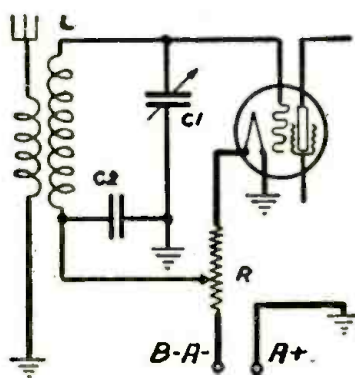

Fig. 5. Correct. With this connection the variable condenser rotor is at ground potential without shorting the filament supply.

It is extremely difficult—practically impossible, in fact—to build a single R.F. choke that has an effective blocking action on the wide band of wavelengths the average amateur short-wave set performs over. Those few experimenters who prefer the shunt feed hookup find it necessary to change chokes as they change tuning coils—a troublesome and altogether unnecessary procedure. The series feed is obviously the better arrangement.

sirable. For instance, the coils may not oscillate from 0 to 100 on the tuning condenser with only 22½ volts, but they "plop" with an uncontrollable bang on 45. If a number of different tubes all behave the same way, with different grid leaks, the only thing to do is to insert a variable resistor in the "B" lead to the detector tube. See Fig. 3, where *R* is to the resistor and *C* a by-pass condenser of .01 mf. capacity. More will be said about by-pass condensers later.

Correct By-Pass

The matter of by-pass condensers deserves a little attention. In the past, most instructions for by-passing have called for condensers of ½ and 1.0 mf. capacity, and these sizes have become more or less arbitrary standards. For short wave sets, where the frequencies run into the millions, these condensers are much, much bigger than necessary. They occupy a lot of room, and the work they do can be done fully as well by condensers of considerably lower capacity. The .01-mf. size is very convenient, because the condenser itself is comparatively small, being of the same dimensions as the usual grid condenser. Its reactance to the high frequen-

cies that roam around in short wave circuits is an infinitesimal fraction of an ohm, so it is perfectly satisfactory from every standpoint.

With the advent of screen-grid short wave receivers assembled on all-metal chasses, we must learn that one side of each tube filament is invariably "grounded" directly to the framework. If we want to bias the grid of the screen-grid tube by using the conveniently available voltage drop across a tapped filament resistor, as in Fig. 4, we find that serious trouble rises. One side of the tuning condenser C1 is also grounded, and since the bottom end of the tuning inductor L must be connected to the same point, we have a short circuit if we bring the end of L also to the tap on the resistor, where it rightfully belongs. Trace out the circuit yourself: "A—" to resistor R, through ground on L and C and back to grounded "A+." Lovely, isn't it? (Result—burnout of resistor, R.—Ed.).

The Tuning Condensers

The trick merely is to insert a condenser between the bottom of L and the grounded side of C1, so that while the radio-frequency current of the tuning circuit will have a complete path in which to circulate, the direct current obtained from the tapped resistor R will not

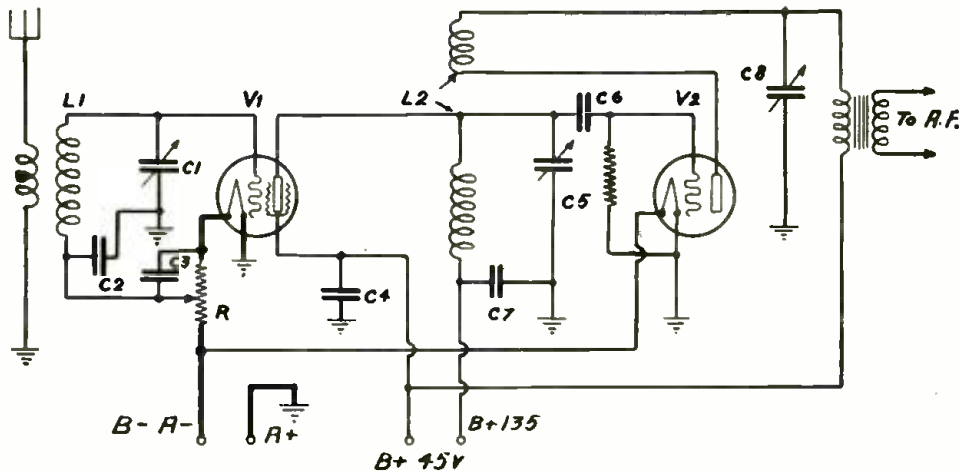

Fig. 6. Schematic circuit of a receiver embodying the ideas described in the accompanying article. This shows how a screen grid tube can be added to a typical regenerative circuit, such as Fig. 3.

get back to the ground. This biasing voltage now has no place to go but to the grid, where we wanted it in the first place. (See Fig. 5.)

Condenser C2 can be anything of large size, .01mf. being a convenient and satisfactory capacity. It is in series with the L-C1 tuning circuit, but it is so large that it has no appreciable tuning effect.

A similar use for a condenser to block direct current but to pass R.F. current is illustrated in Fig. 6, which is a diagram of a typical tuned screen-grid short wave set. The R.F. portion is like that of Fig. 5, with an additional .01-mf. bypass C3, across the filament resistor for the screen grid tube V1.

The latter is direct coupled to the detector, V2. The problem is to feed 135 volts of "B" battery to the plate of V1 without starting any fires in the detector circuit.

The blocking condenser C7, again of .01-mf., does the trick with the aid of the grid condenser C6. The "B+135" is led right through the grid coil of the detector plug-in coil L2, but is insulated from the grid of V2 by condenser C6, and is prevented from short circuiting back to ground by the condenser C7. The latter completes the R.F. tuning circuit of L2 and C5, just as C2 performs an identical service for L1 and C1.—(Courtesy Radio-Craft.)

Home Practice Radio Code Outfit

TO obtain the best there is in radio, learn the code. Just to listen to broadcast is to miss half the fun.

As the circuit indicates, the hook-up is the Armstrong regenerative arranged in a somewhat unusual fashion; that is, the circuit is permitted to "howl".

The grid coil is wound on a regular three inch tube, to a total of 75 turns, using number 26 cotton covered wire.

The secondary, or rather, the plate coil, consists of 55 turns of the same size wire wound on a form which will snugly fit inside the grid coil, after the form has been wound with the wire. This tubing may be a piece of cardboard or perhaps better material, of the exact size, or it can be improvised

AERIALS???

What kind of short-wave receiving aerial have you found best?
Write us and give diagram with dimensions. All articles accepted and published will be paid for at space rates.—Editor.

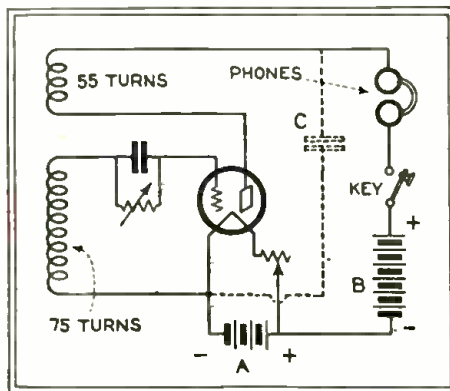

Schematic circuit of a code practice unit. It sounds like a high-power code station.

from a piece of the three inch tubing, by cutting a strip from the tube and forcing the two edges together.

It is desirable but not essential that the plate coil snugly fit the grid coil. Both coils are wound in the same direction.

To operate the unit, adjust the plate coil to obtain the desired note.

A variable grid leak, indicated in the schematic, is an aid in arriving at a satisfactory tone and volume adjustment.

Any handy tube can be used with the correct "A" voltage. If the circuit does not oscillate, try reversing the plate leads, changing the tube, and checking the grid return lead to make certain it connects to "A" minus.—M. H. BERRY.

—(Courtesy Radio-Craft.)

Short Wave Question Box

Edited by R. William Tanner, W8AD

Short Wave Super-Heterodyne

(8) Albert Sobel, Kew Gardens, N. Y., asks us:

Q. 1. Which circuit do you consider best for short-wave reception, the super-heterodyne, super-regenerative, or plain regenerative with a tuned R. F. stage?

A. 1. Beyond all question of a doubt, the super-heterodyne is the most sensitive and selective of all. It is, however, a complicated circuit for the novice to construct. If cost is a consideration, the super-regenerative offers great possibilities; but, in order to eliminate the loud "rushing" noises, common to this circuit, rather critical adjustments are necessary. The plain regenerative with a tuned R. F. stage seems to be in vogue at the present time. A fair degree of gain may be obtained, but selectivity is poor unless it is correctly designed. Correct design does not mean using all of the detector coil in the plate circuit of the R. F. tube. Amplification falls off considerably as the wave goes down. Below 40 meters the gain factor in the R. F. stage will not exceed 5 or 6.

Q. 2. Please print constructional details for a suitable short-wave super-heterodyne, specifying the correct I. F. amplifier and giving values of parts used.

A. 2. An article describing a very efficient short-wave super-heterodyne, written by the editor of this department, appears in this issue. With this receiver, distant stations can be brought in on the loud speaker with volume almost equal to regular broadcasting.

Q. 3. Are three stages of A. F. amplification suitable for short-wave work, or is this combination too noisy?

A. 3. Such a high degree of A. F. gain cannot be used successfully for short-wave reception. Howling, due to feedback, is of great proportions and is far more serious than in regular broadcast receivers. A resistance-coupled first and transformer-coupled second stage are sufficient. A new type of audio amplifier has recently been developed, especially for short-wave work, and its details will soon be published.

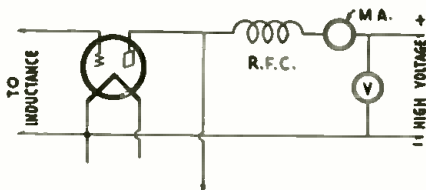

Diagram showing connection of milliammeter and voltmeter to measure input of transmitter.

THIS question and answer department is edited by Mr. R. William Tanner, well known operator of short-wave amateur radio station W8AD. Mr. Tanner has written a great many articles for the radio press and has had considerable experience in designing and constructing both short-wave transmitters and receivers. Not more than three questions should be asked and all letters containing questions should be addressed to the Editor, Short-Wave Question Box, at the publisher's address. State your questions briefly. Questions cannot be answered by mail.

How to Determine Input

(9) Hayes Steinhauser, Norwich, N. Y., inquires:

Q. 1. How are the input and output of a low-power transmitter determined?

A. 1. The input in watts is found by multiplying the plate voltage of the output tube (oscillator or last R. F. power amplifier) by the plate current. A voltmeter and milliammeter are necessary. These are connected as shown in the diagram. A discussion of the method of determining the output cannot be given in these columns for lack of space. Roughly, an efficiency of 30 to 40 per cent may be obtained from an oscillator. In an R. F. power amplifier, the efficiency is much higher, 80 to 90 per cent being quite common.

Q. 2. Can an A.C. meter be used to measure direct current?

A. 2. Yes, but not very accurately.

Q. 3. Would a Loftin-White amplifier be sufficient to run a dynamic speaker from a two-tube set?

A. 3. This excellent amplifier will easily run a dynamic speaker but a two-tube set is hardly large enough to work the power tube at full output. The gain of this amplifier is rather high for a short-wave tuner and a less elaborate amplifier is recommended. See answer to question 8 (3).

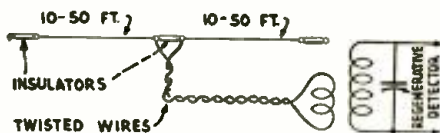

How to connect a doublet receiving antenna to a regenerative tuner.

Antenna Inquiries

(10) Charles Rodgers, Nashville, Tenn., inquires of this department:

Q. 1. Will you print a circuit for a doublet receiving antenna, showing how it is connected to a regenerative tuner?

A. 1. The diagram is given here. The antenna may be erected inside or outside. The lead-in, if it can be considered such, should be of twisted-pair cable. The antenna coil, coupled to the detector grid coil, will generally consist of a

greater number of turns than with the usual antenna-ground connection.

Q. 2. Will a short-wave detector function with a negative bias on the grid?

A. 2. If regeneration is not employed, a biased detector is preferable. Tuning will be considerably sharper, because of the high input impedance of the tube. When regeneration is employed, a grid-leak detector is considered better. (See page 87, June-July issue of SHORT WAVE CRAFT.) Personally, I have used only the biased detector, for some time, in all of my short-wave receivers, with or without regeneration. With a low negative bias (approximately 2 or 3 volts) no trouble has been experienced in obtaining smoothness of control, etc.

What Is a "C" Amplifier?

(11) Leslie Newton, Berkley, Calif., writes us:

Q. 1. What does "a type 'C' amplifier" mean, when applied to a transmitting circuit?

A. 1. A "type 'C' amplifier" operates in such a manner that the power output varies as the square of the input plate voltage. The grid is supplied with a bias considerably greater than that required to produce plate-current cut-off. The peak excitation voltage must be high enough to swing the grid to a high positive value, in order to secure a large amplitude of plate current. Such an amplifier gives very high efficiency. It is used, mostly, as a modulated power amplifier in radio-telephone circuits.

Q. 2. Which type of tube is best for an oscillator in a crystal-controlled transmitter, using a '10 in the output stage?

A. 2. A '71A will give greater output when employed as an oscillator than any of the smaller tubes.

Q. 3. Is it necessary to use a push-pull oscillator and buffer stage, with a '10 push-pull output amplifier?

A. 3. No, single-ended units are sufficient; however, a special tank inductance must be employed between the power stage and the intermediate. This is shown in the diagram.

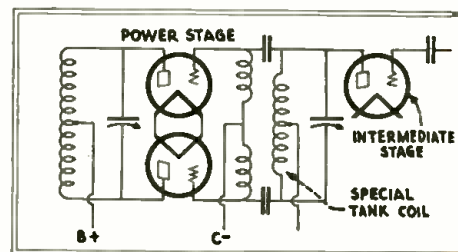
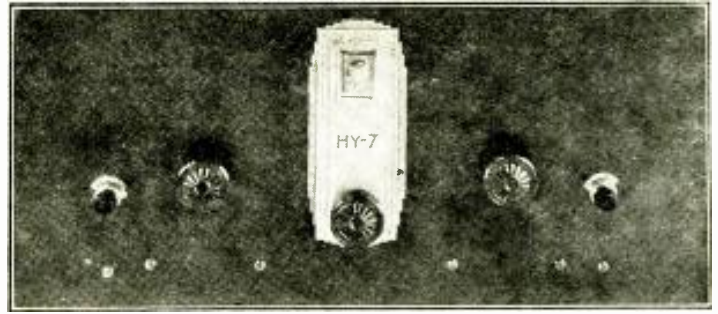

Diagram showing connection of tank inductance, between the power stage and the intermediate stage of an amplifier.

The Hatry HY-7 Short Wave Super-Het Receiver



Front view of the HY-7 super-heterodyne designed for short-wave reception.

THE photographs and wiring diagram shown herewith give a good idea of the appearance and general layout of the newest short-wave receiver, the HY-7, which possesses outstanding efficiency from the viewpoints of selectivity, sensitivity and quality, as well as volume. The first detector utilizes a '22 type screen grid or 4 element tube and this tube is used as a space-charge detector. For the oscillator stage a '01A tube is employed, as it makes a very stable and long-lived oscillator. For the intermediate stages of this super-het, Mr. Hatry uses '22 screen grid tubes with their high amplification. In the second detector stage either a '40 or '12A tube is recommended and in the audio stage either a '01A or '12A tube can be employed and preferably a '71A. The HY-7 super-heterodyne is supplied in kit form and is shipped by the manufacturer with the major components assembled and ready for wiring, which is very simple. The article in the next issue will give the complete details on the oscillator and detector coils, etc.

In the next issue: Complete details for building the HY-7 Super-heterodyne described by Mr. L. W. Hatry. It is recognized by experts that the super-heterodyne principle gives the maximum selectivity and sensitivity when properly designed.

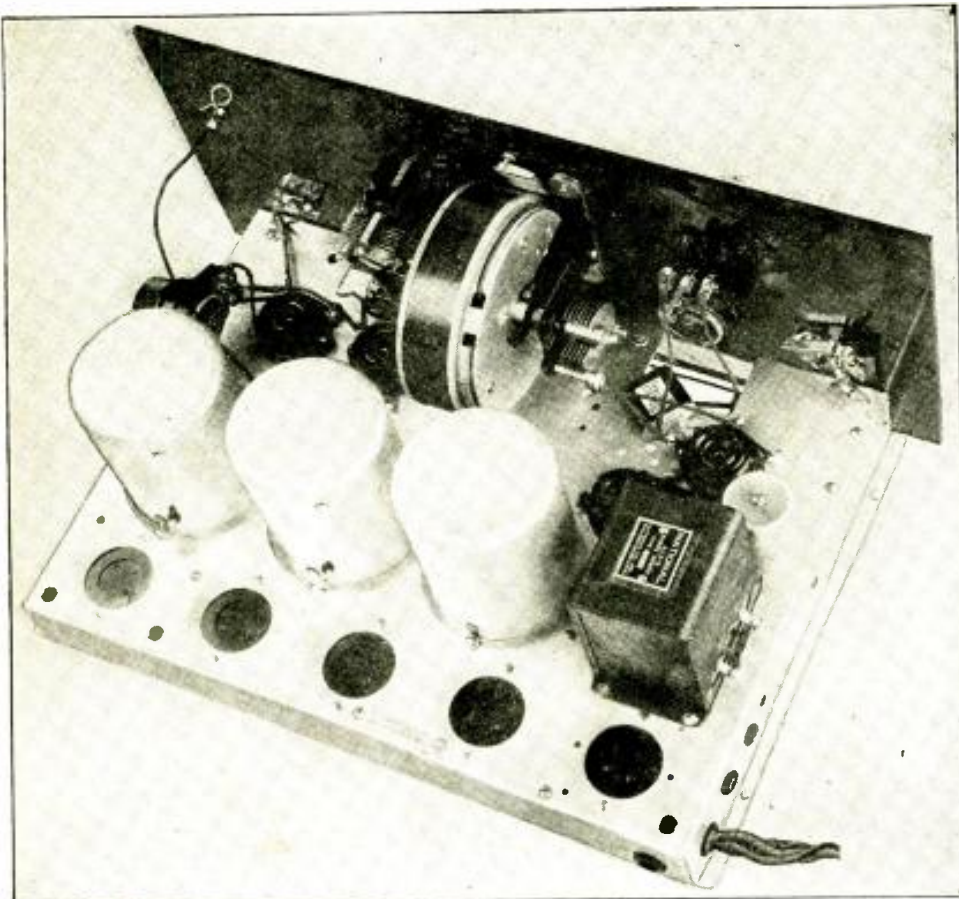

Rear view of the HY-7 super-heterodyne for short-wave reception, as designed by Mr. L. W. Hatry, well known radio engineer and short-wave specialist.

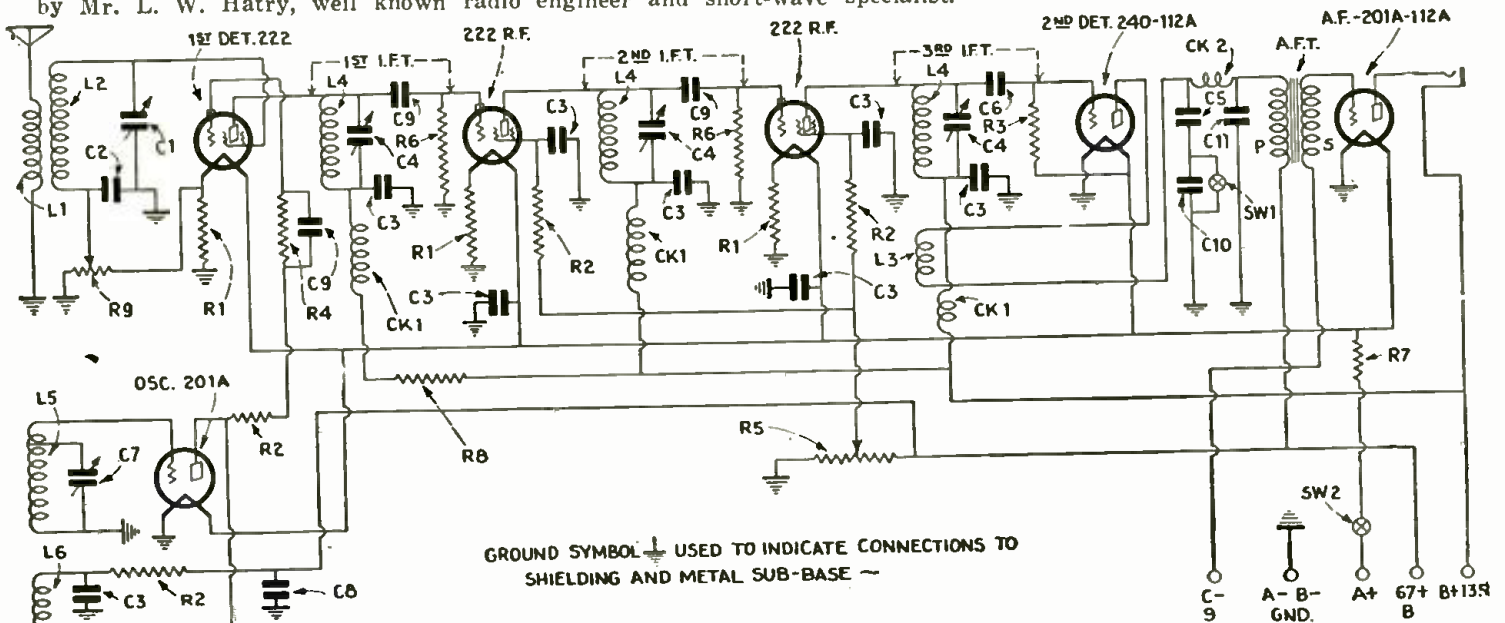

Complete wiring diagram of the 6-tube short-wave receiver designed by Mr. L. W. Hatry, and which embodies double detector principle with intermediate amplifier.

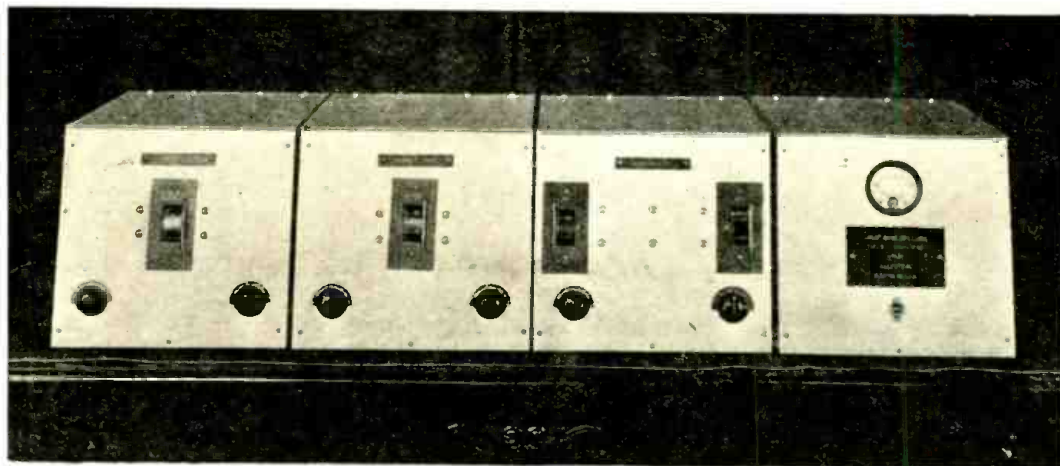

Treat your customers to a concert direct from Hawaii!

THEN WATCH THEM BUY THIS AMAZING SHORT-WAVE RECEIVER

A set designed, built and sold for one purpose only—The clear, perfect reproduction of short wave transmission. So amazing is its sensitivity, that stations in remote parts of the world come in clearly and strong.

The New Leutz Short Wave Receiver is of unit construction throughout permitting the use of detector and Audio Frequency alone for local reception, with one or more stages of Radio Frequency

for the reception of weak or very distant signals.

Shielding is of a new high efficiency, permitting high amplification without distortion.

Sooner or later every radio owner will be going after the short wave programs and television. Get in on the ground floor with this up-to-the-minute set.

You will want complete particulars of course. We are ready to give you the whole story. Write or wire for it now.

EUROPE
BALDWIN M. BALDWIN
1 Boulevard Haussman
Paris, France
Cables Experinfo Paris

C. R. LEUTZ INC.
RADIO ENGINEERS AND MANUFACTURERS
ALTOONA, PA., U. S. A.

WEST COAST
B. J. HOWDERSHELL
Detwiler Bldg.
412 West Sixth St.
Los Angeles, Calif.

CABLES "EXPERINFO"

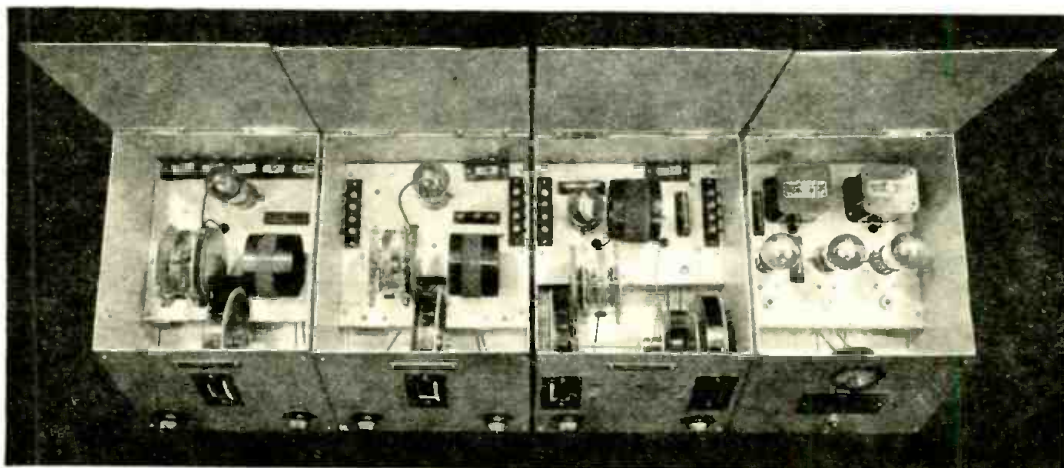

SHORT-WAVE COILS

De Luxe Models



Precision de luxe short-wave coils, 15 to 200 meters, for use with .0005 mfd. straight frequency line condensers, so that two plug-in coils cover this wide range. Mean diameter, 2.8 inches. Fibred forms, 93% air dielectric. Mounted on plug-in bases.

Secondaries have 3 turns and 17 turns respectively. For the short-wave converter described by Henry B. Herman, use Cat. No. SW-CON-L (five coils), at \$7.10, consisting of two sets of coils and an adjustable plate coil, but not including coil socket base, as this is built into the official subpanel. Bases (Cat. SW-L-B) are obtainable at 30c each, extra. Two would be needed for a converter.

Those desiring coils for short-wave TRF, 15 to 150 meters, use .0011 mfd. condensers, need three coils for each condenser (Cat. SW-SOAN-L). Coil sockets are included, also adjustable winding and regeneration winding. Price \$6.10.

Tube Socket Models



Coils fit in standard UX (4-prong) tube sockets, for .00014 mfd. tuning condenser coils to a set (15 to 150 meters); use .00014 mfd. condenser (Cat. SW-TB-L) at \$1.60. The coil forms are equipped with finger handles.

CONVERTERS

Parts for short-wave converters, as described by Henry B. Herman:

A.C. model (Cat. AP-AC-CON) includes drilled, socketed panel, cabinet, two Hammarlund .0005 mfd. SFL, two National VBD dials, five precision de luxe coils (Seven Grid Coil Co.), filament transformer, everything else. Price \$21.70.

Battery model (Cat. AP-DC-CON), \$19.70.

Station List FREE

Send in a stamped, personally addressed letter and we will send a list of short-wave stations of the world, with schedule of hours on air, and how to find foreign stations by reference to American ones. Ask for National short-wave circular.

- Hammarlund .0005 SFL tuning condenser (Cat. H-SF-5) \$3.30
- Heath Radiant .00014 tuning condenser (HB-4).....\$1.75
- National VBD dial with pilot bracket (N VBD).....\$1.80

GUARANTY RADIO GOODS COMPANY

143 West 45th Street
New York, N. Y.
(Just East of Broadway)

GUARANTY RADIO GOODS CO.
143 West 45th Street
New York, N. Y.
(Just East of Broadway)

Enclosed please find \$..... for which please ship.

- ☐ Cat. SW-CON-L (five coils) \$7.10
 - ☐ Cat. SW-L-B (coil socket strip) each..... 30
 - ☐ Cat. SW-STAN-L (four coils) 6.10
 - ☐ Cat. SW-TB-L (three coils) 1.60
 - ☐ Cat. AP-AC-CON 21.70
 - ☐ Cat. AP-DC-CON 19.70
 - ☐ Cat. H-SF-5 3.30
 - ☐ Cat. HE-4 1.75
 - ☐ Cat. N-VBD 1.80
- If C.O.D. shipment is desired put cross here.

Your Name
Street Address
City..... State..... (SWC)

How to Build a Super-Het for Short Waves

By R. WILLIAM TANNER

(Continued from page 152)

D.C. is flowing in the magnet coils. The output of the tube is fed to the grid (or grids) of the power stage through an .006-mf. coupling condenser C8. The grid resistor R10 should have a value of 0.25- to 0.5-megohms.

Another improvement is the use of R. F. chokes, similar to that in the second detector's plate circuit, in the plate and screen-grid leads to the I. F. tubes. This will, of course, reduce feedback to a very small minimum and, theoretically, should increase the gain per stage.

This efficient super-heterodyne is rather complicated in design and construction; but the builder will be amply repaid for the time and money spent.

List of Components

- L, L1—Antenna and first-detector plug-in coils (see table);
- L2, L3, L4—Oscillator plug-in coils (see table);
- L5, L6—I. F. coil;
- L7, L8—I. F. transformer;
- L9, L10, L11—I. F. transformer;
- BPF—Band-pass filter coil;
- C—First-detector tuning condenser, .00015-mf.;

- C1—0.1-mf. by-pass condensers;
- C2—Oscillator tuning condenser, .00014-mf.;
- C3—Oscillator blocking condenser, .0005-mf.;
- C4—I. F. tuning condensers, .0001-mf. fixed and .0001-mf. midget;
- C5—.00015-mf. fixed condenser;
- C6—1-mf. by-pass condensers;
- C7—2-mf. speaker coupling condenser;
- RFC—Short-wave R. F. choke;
- RFC1—Long-wave R. F. chokes;
- AFC—30-henry speaker filter choke;
- R—5,000-ohm first-detector bias resistor;
- R1—1,000-ohm oscillator bias resistor;
- R2—500-ohm I. F. bias resistors.
- R3—25,000-ohm second-detector bias resistor;
- R4—50,000-ohm regeneration resistor;
- R5—First A. F. bias resistor, 2,000-ohm;
- R6—50,000-ohm potentiometer.
- R7—100,000-ohm resistor for A. F. transformer;
- R8—1,600-ohm second A. F. bias resistor;
- R9—60-ohm, center-tapped filament resistors.

COIL TABLE—WIRE IS ENAMELED, IN ALL GAUGES

Meters	Band	Turns L	Turns L1	Turns L2	Turns L3	Turns L4
20	20	2 No. 24	7 No. 18	1 No. 24	6 No. 18	5 No. 24
40	40	3 No. 24	13 No. 18	2 No. 24	11 No. 18	6 No. 24
80	80	5 No. 24	25 No. 22	5 No. 24	21 No. 22	9 No. 24
160	160	10 No. 24	46 No. 24	12 No. 24	39 No. 24	13 No. 24

NOTE: Coils L2 and L4 are subject to modifications, as plate and grid voltages will vary with individual receivers. If no signals are heard, first determine if oscillator is working properly; if not, add more turns to L4. If oscillations are being produced, and still no signals, increase L2.

"My Favorite" Short Wave Receiver

By F. W. SCHNELL

(Continued from page 116)

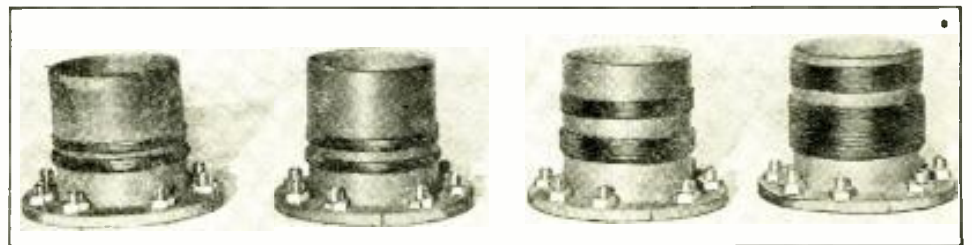

Fig. 5 illustrates a set of 4 coils covering from 15 to 90 meters, the constants of which are given in the accompanying table. Other coils can be made to cover the other wavelengths, or such of them as may be desired.

COIL WINDING DATA FOR AMATEUR BANDS

Wavelength in Meters	L1 Ant. Coil	L2 Grid Coil	L3 Plate Coil	L4 Secondary Coil	L5 Tickler Coil
19 to 24	4 turns	6 turns	5 turns	5 turns	5 turns
35 to 44	7 turns	14 turns	10 turns	10 turns	10 turns
72 to 90	12 turns	26 turns	26 turns	25 turns	16 turns

NOTE—All coils are wound with No. 24 D. S. C. wire.



On All Large Newsstands

The How-and-Why of Aircraft in Plain English!

A MATEUR aviation constructors and aviation students—comprehensive chapters on construction of several planes, with detailed practical hints on motors, instruments, gliders and other parts are found in this invaluable book. Replete with over 200 photographs, illustrations and working diagrams—also complete descriptions and photographs of latest types of planes.

Large 9"x12" in size, 4 colored cover, 100 pages.

50c

The Copy

❖ CONTENTS ❖

FEATURES:

- How I Broke the Women's Altitude Record, by Elinor Smith.
- Can a Plane Rise When Tied to a Tree?
- My Glider Trip Across the Continent, by Captain Frank M. Hawks.
- How Shall We Fly Tomorrow?, by Captain "Eddie" Rickenbacker.
- The Packard Diesel Aircraft Engine, by Captain L. M. Woolson.
- Opportunities for Young Men in Aviation, by Walter Hinton, Famous Navy Pilot.
- How to Build the Storms "Flivver" Plane, by H. Winfield Secor.
- The Anne Lindbergh Glider Club for Girls, by Peaches Wallace.
- Some Real Facts About Parachutes, by George Waite, Pres., Irving Air Chute Co.

AIRCRAFT ENGINES:

- The Packard Diesel Aircraft Engine, by Captain L. M. Woolson.
- Merits of the Radial Air-Cooled Engine, by F. B. Hart, Engineering Department, Wright Aeronautical Corp.
- A New Aircraft Engine for Light Planes.
- Handy Aircraft Engine Kinks, by George A. Luers.

AIRPLANE CONSTRUCTION:

- How to Build the Storms "Flivver" Plane, by H. Winfield Secor.
- Further Construction Details on the Lincoln Sport Plane.
- How to Build the Heath Super-Parasol

GLIDERS:

- My Glider Trip Across the Continent, by Captain Frank M. Hawks.
- The Anne Lindbergh Glider Club for Girls.
- How to Build a Simple Glider, Powered With a Motorcycle Engine, by George A. Gerber.

MODEL AIRPLANES:

- A Fast Army Pursuit Model Plane—and It Flies!, by R. W. McCorkle.

FOR THE STUDENT FLIER:

- Learning to Fly in a Huge Wind Tunnel, by F. E. Loudy.
- It's Easy to Fly—The First Lesson—Illustrated. These Machines Teach You How to Fly.
- Making Up Solo Flying Time for License, by F. "Rex" Edsted, Ex-War Pilot.

MISCELLANEOUS:

- Who Said An Airplane Pilot Wasn't Busy?
- Robot Acts As Pilot.
- Trap Door + Parachute = Happy Landing.
- Happy Landings and Crack-Ups—The Reader's Viewpoint.
- Colonel and Mrs. Lindbergh Make New Record.
- Can I Become a Licensed Pilot? by Don Charles.
- Some Real Facts About Parachutes, by George Waite.
- What Is Your Aviation Question? Answered by F. "Rex" Edsted, Ex-War Flier and Former Officer in Royal Flying Corps.
- Latest Aviation Patents.
- Book Reviews.

MAIL COUPON TODAY!

AVIATION MECHANICS SWC-8
96-98 Park Place, New York, N. Y.

As per your special offer, I enclose \$1.80, for which please enter my subscription to AVIATION MECHANICS for one year. I understand that it is published every other month.

NAME
ADDRESS
CITY and STATE.....

AN UNUSUAL OFFER!

For a limited time only charter subscriptions will be accepted at the reduced rate of \$1.80 per year. (Regular Price, \$3.00). Take advantage of this opportunity and clip out the coupon and mail TODAY.

(Aviation Mechanics is Published Every Other Month)

Book Prices Slashed!

AS LONG AS THE SUPPLY LASTS—

Sent Prepaid
to You

35c the Copy 3 for \$1.00



No. 1
Here you will read the interesting and unusual experiences that happen behind the closed doors of a doctor's inner office. Written in diary form by Maurice Childekel, M.D. Unbelievable but true.

All of these books sold for 50c. a copy up to now. But in order to clean our stock we are selling them at 35c. a copy AS LONG AS THE SUPPLY LASTS.

If you ever wanted a fine book at a big bargain, here is your last chance.

NO FICTION

POPULAR BOOKS aim to educate you and entertain. They never contain fiction. They are all on SPECIAL SUBJECTS. Each book is compiled by EXPERTS. Every book contains far more matter than the usual \$2.00 book, and gives you a wealth of material for the price of a high-class magazine.

All books are uniform in size—the large (9 x 12-inch) page which is a favorite with readers; heavy and durable paper only is used, and the type is selected for its readability. The covers are always in four colors and varnished to keep from soiling.

Large 9" x 12" in size—A colored cover—100 pages per book

The majority of POPULAR BOOKS are profusely illustrated. **FILL IN THE COUPON AND ORDER TODAY.** We accept money orders, U. S. Stamps or cash.

POPULAR BOOK CORP.
93H PARK PLACE NEW YORK



No. 2
The first complete book in the English language. Gliding is a sport that can be practiced by everyone. It is the easiest, quickest and cheapest means of learning to fly. This book enables you to build and fly your own glider with little work and small expense. Written by expert gliders.



No. 3
Dr. David H. Keller, M.D., discusses such important topics as Sexual Physiology of the Young Man, Love and Marriage, The Normal Sex Life, Psychology of the Young Girl, Companionate Marriage and dozens of other important topics from a scientific standpoint. Contains the best and most advanced thoughts on Life and Reproduction of interest to everyone — enlightenment on every page.



No. 3
SNAPPY HUMOR is a collection of the world's best wit, culled from periodicals of every language. It contains the cream of the world's mirth, French, German, English, etc., etc., with rich and snappy illustrations, also many varied stories. Over 750 Original Illustrations. Plenty of laughs — thrills on every page.



No. 4
No few people today know the schemes introduced by the racketeers—and the astounding success with which they extract tremendous sums of money from people. Only government inspectors and agents are familiar with their methods of extortion—the baffling ways of the racketeers. In RACKETEERS dozens of outstanding schemes and the names of the leaders are exposed.



No. 6
READ 'EM AND LAUGH—The pet story of each of a hundred world-famous celebrities, personally interviewed by the author. Each person is introduced by a comic introduction followed by an uproarious caricature by the author.

How Short Waves Are Used to Produce Artificial Fever

(Continued from page 109)

two half-wave, hot-cathode, mercury-vapor tubes. In conjunction with a filter system, this unit furnishes the 3,000-volt direct-current supply for the oscillator. An auto-transformer is connected in the primary circuit of the high voltage transformer to provide plate-voltage regulation.

The condenser plates are of aluminum, 28 by 18 by 1/8-inch, covered by hard rubber plates 30 by 20 by 1/4-inch, to prevent arcing, should the patient or attendant come in contact with the plates. In this field of undamped waves between the plates there is a rapid alternation of 3,000 volts drop of potential.

The patient is suspended on interlaced cotton tapes stretched across a wooden frame, the under surface of which is covered with composition boards, forming an air chamber beneath the body. A cover of the same material is fitted over the frame, so that the head of the patient projects through an opening at one end; thus there is formed a fairly tight air chamber around the body as it lies on the tapes. The patient rests on his back and the plates are placed at each side of the box; so that the waves oscillate through the body from one side to the other. The plates' separation can be varied, but as a rule has been kept at 30 inches. Two small hair dryers are placed in openings at the foot, one above and one below, to circulate hot air around the body. These decrease the heat loss, and equalize the humidity, throughout the enclosed atmosphere. By applying the plates in this manner and by enclosing the body, it is heated rapidly without causing great discomfort to the patient. When the desired temperature is reached it may be maintained by decreasing the voltage, by increasing the plate distance, or by employing only the hot-air blowers.

The 10,000,000-Cycle Tube

The tube used for the production of the 30-meter waves is a four-element screen-grid tube, designated as the G. E. "Type PR-861 Plotron." Especially adapted for use at the higher frequencies it has a nominal output rating of 500 watts.

The filament, grid and plate are supported on separate stems, with the leads brought out at separate seals; thus insuring high insulation and low electrostatic capacities between electrodes. The filament is of thoriated tungsten in the shape of a double helix, supported from a center rod, and requires no tension springs. The grid and plate are cylindrical; the plate has six wings for dissipation of heat.

The fourth electrode, the screen-grid, consists of a close mesh or winding placed between the control grid and plate, and extends the full height of the tube. It is supported by suitable means on the filament and control-grid stems. It has two leads; one of which is brought to the blade of the base on the filament arm, and the second through a separate seal to a base near the grid end of the tube.

POPULAR BOOK CORPORATION,
93H Park Place, New York, N. Y.

Please send me the book (or books) selected below. I have encircled the numbers I desire. I enclose remittance for \$ at the rate of 35c a copy or 3 books for \$1.00. You are to send the books to me postpaid (CANADA and FOREIGN 5¢ extra postage per book).

I have selected the following books: 1 2 3 4 5 6

NAME
ADDRESS CITY AND STATE

For Experimental Uses

In connection with the exhibition of the equipment and the announcement of the work with artificial fevers, Dr. Whitney issued a statement emphasizing the fact that the equipment is being used at present for experimental purposes only:

"Our policy concerning this new method of high-frequency therapy has been to sell no apparatus but to study it ourselves and to assist research by others. We have built a number of outfits, and have lent most of them to competent research groups. The expense has been considerable, and we could hardly justify increasing the number of these loans.

"Therefore, if the medical profession, in view of the experimental results already announced, feels that such researches should be multiplied, while we are still unwilling to sell such outfits generally until their utility is more completely proved, we are now willing to sell apparatus to accredited medical institutions equipped for research work."

Television on Short Waves

By D. E. REPLOGLE

(Continued from page 113)

and-white are transmitted. It must not be thought that the film transmissions are lacking in interest, as specially-made reels are employed. The scenarios are written with special attention to the requirements of television, and are full of action to compensate for the lack of detail. The half-tone films consist of vaudeville acts, famous personages, etc., and have, for the most part, sound accompaniment. The direct pick-up and half-tone film subjects from W2XCR in Jersey City have their sound accompaniment broadcast over Station W2XCD in Passaic, N. J. Thus, you not only may see through the medium of your television, but may also hear, by tuning in this latter station on your broadcast receiver.

It must be held in mind that the former failure of television was due partly to the fact that apparatus was allowed to pass into the wrong hands. Television today is in the same state as radio telephony at the close of the war. Much has been done toward its development in the laboratory—what it now needs is demonstration in service.

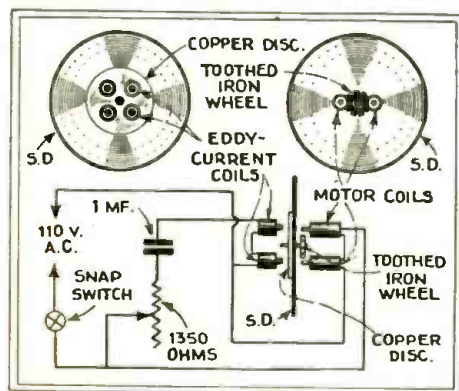

The ingenious driving and synchronizing system of the latest Jenkins radiovisor.

ELECTRIC AND D. C. MODELS

SCOUT MODEL
Chassis dimensions,
11 1/2" long; 5 3/4"
high; 7" deep

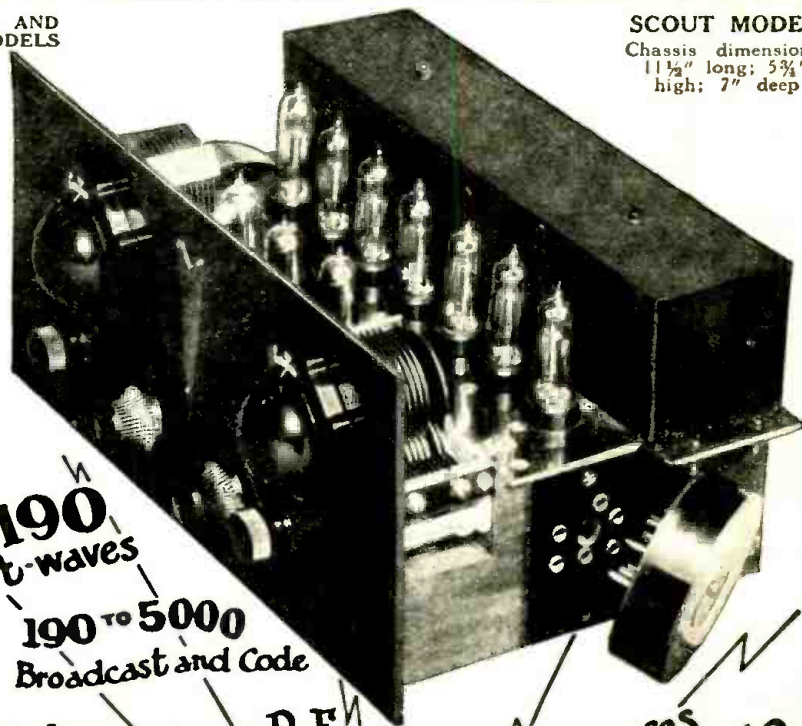

9 to 190
Short-waves

190 to 5000
Broadcast and Code

10 Tubes ~
4 Stages R.F.

2 Stages
Audio

MERCURY
Short-wave Radio

WHEN you buy the MERCURY 10-tube Short-Wave Superheterodyne you are assured of definite results for this receiver readily picks up short-wave phone, broadcast and code from Australia, Europe, South America, Central America, South Africa, and other distant countries.

The statements we make about the MERCURY, either here or in our Booklet, are actual facts. Each receiver is individually assembled and tested for DX results in our laboratory at Toronto, Canada. No mass production! The MERCURY uses a special Superheterodyne circuit, containing modifications and changes of our own design, which are patented. TEN R215A tubes are used—the tube used by the NAVY as standard in their sets. The circuit provides 4 Stages of R. F. and 2



MERCURY
"Messenger of the Gods"

Stages of Audio Amplification, bringing in stations on any type of loudspeaker.

Current consumption of all 10 tubes is only 1/2 ampere at approximately 5 volts. Milliampere drain on "B" supply 12 milliamps. Available in both Electric and D. C. models. Very compact; chassis, 11 1/2" long; 5 3/4" high; 7" deep.

Although designed primarily for short-wave broadcast and phone reception, wavelengths from 9 to 5,000 and upwards can be covered. On Ultra-Short bands of 9 to 32 meters, advantage is taken of special split condenser arrangement, allowing even spacing of stations over the entire range of the receiver. The 190-550 meter range is covered with one set of Coils only; selectivity is sharp enough for all practical purposes.

Write for Booklet and Prices

If you are interested in knowing more about this remarkable short-wave instrument, write for FREE Booklet and Prices

The H. M. KIPP CO., Ltd., 447-A Yonge Street
TORONTO ONTARIO CANADA

THE H. M. KIPP COMPANY, Limited
447-A Yonge Street, Toronto, CANADA

Please send me Free your Short-Wave Booklet and Prices on the MERCURY.

Name..... Address.....
City..... State.....

(Please write name of local dealer in side margin)

The New TRIMM Headset

Special Dependable No. 65

All Bakelite case; terminal blocks molded in; highest grade forged, over-size chrome magnets.

Same care in design, construction and materials as in Trimm Professional and Dependable Headsets.

Remarkably Low Prices

Trimm Radio Mfg. Co. 847 W. Harrison St. Chicago, Ill.

SIGNAL Wireless PRACTICE SET



LIST \$3.40

For practicing the code. Equipped with high grade key and high frequency buzzer. Each set complete with booklet "Fundamentals of Wireless Telegraphy." If your dealer cannot supply you write direct—

SIGNAL ELECTRIC MFG. CO. MENOMINEE, MICH.

Aluminum Box Shields

Beautiful silver dip finish, 5 x 9 x 6 inches, \$1.89. 10 x 8 x 6 inches, \$3.25. We make any size to order in 24 hours.

Genuine Baldwin Type "C" Phones, a necessity for short-wave reception, \$3.65 a pair.

Test Leads, 3 ft. long, hard rubber sleeves, 59c.

Bakelite neutralizing screwdrivers, 50c.

BLAN THE RADIO MAN, Inc. 89SW Cortlandt St. New York

SEND NOW FOR OUR LATEST RADIO BARGAIN BULLETIN, CHOCK FULL OF REAL LIVE BUYS AT REMARKABLY BIG SAVINGS TO YOU.

AMERICAN SALES CO. 19-21 Warren st. N. Y. City

SHORT WAVE HINTS

THE editors shall be pleased to hear from all short wave experimenters and set builders who have some practical hints on the construction and operation of short wave receivers and also transmitters. Sketches and photographs are greatly desired with a brief description of the hint or wrinkle. Address all sketches and manuscripts to Editor, Short Wave Craft.

What Is the Wavelength of Your Body?

By A. BINNEWEG, JR.

(Continued from page 153)

Electrical Resonance of the Body

The human body also has a natural electrical frequency, due to its inductance and capacity; so that the current and voltage distributions will be somewhat as shown in Fig. 1C. A wire has uniform inductance along its length; but the human body, because of its irregularities, has different values of inductance and capacity and, therefore, the distribution will not be so uniform. A big chin would have more electrical capacity to earth than a small one, consequently the inductance and capacity of different bodies will vary.

It should be noted that the current and voltage distributions occur as shown only when the wire is ungrounded, at the lower end. Thus, the human being must stand on an insulating stand to obtain the same current and voltage relations. If the subject should stand on the earth with his bare feet (thus making a better "ground") the relations shown in Fig. 1 would not hold. The voltage and current relations at resonance would shift to those shown in Fig. 2; one-quarter wavelength would now give resonance with the body. In any case, if the oscillator power were sufficient, one's hair would stand on end.

High Power Produces Fear

It is interesting to wonder about the effects which could be observed, should extremely high power be used at the natural frequency of some human being, male or female. In the first place, the hair would undoubtedly stand on end, because of the high voltage which results from the standing waves on the body. There would be, also, a bluish discharge from the head, should the power be very high. No other harmful effect would result except a peculiar heating effect somewhere near the electrical center of the body, due to the high current value occurring there. These currents, due to the enormously high frequency, however, tend to circulate on the surface of the skin and thus should not cause any harmful internal effects, so far as we know. However, this is true only for extremely high power; and such can only be obtained in expensive research laboratories.

No "Death Ray"

Someone has suggested that, if the power were sufficient, whole armies could be annihilated (or, at least, made very uncomfortable) by a powerful radio beam tuned to human frequency. There are, however, many scientific facts which make this not only impractical but almost impossible.

In the first place, every human body has a different natural frequency. Thus, such an oscillator would not only require extremely high power but would have to give that power over a considerable range of frequencies. This, in itself,

makes the use of an ordinary reflector system impossible, because it operates at maximum efficiency at only one frequency.

In the second place, assuming that all the above difficulties had been overcome, the foe could overcome the effect of a powerful beam by simply taking off their shoes and walking on dampened earth.

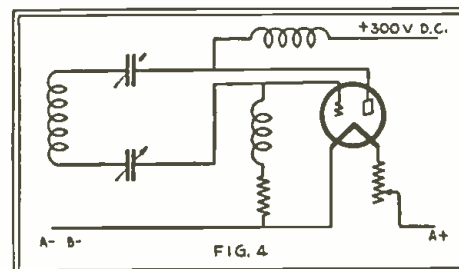

3 meter oscillator circuit used in 3 meter tests.

There are other ways of overcoming the effects of such a beam. A man could also "detune" himself by lying flat on the earth (thus becoming grounded) or simply by going to his knees. For every destructive weapon of war, science quickly finds a defense.

The reader is perhaps acquainted with the fact that ordinary radio waves are not apparent to any of the human senses. The reason why the resonant period of the human body enables us to detect the presence of a powerful wave is that currents are induced on the surface of the body, creating heating effects which can be detected. All ordinary waves, however, cannot be detected in any way because their effect is entirely negligible.

Thus the plan for using powerful beams to destroy life in time of war is

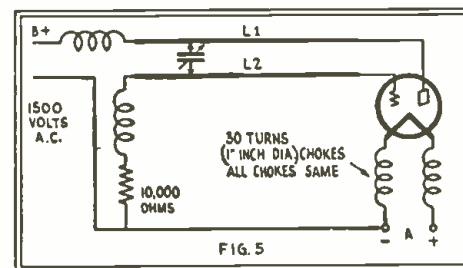

Oscillator hook-up for high frequency tests; a UX-852 tube is used. L1 and L2 are 16-inch rods.

not practical; it is well nigh impossible—so don't fear such a scheme.

Ultra-High Experimentation

There are some extremely interesting tests, which can be performed by short-wave experimenters, along these lines. It was found, in the tests previously mentioned, that waves can be reflected from the human body. In fact, an interesting burglar alarm, using this prin-

ciple, was arranged for demonstration. An oscillator, operating at about 3 meters, was arranged with a transmitting aerial, as shown in Fig. 3. Nearby, a receiving aerial was arranged and a suitable receiving set connected to it. To the output of the receiver, a sensitive relay was connected, with output leading to a burglar-alarm bell and suitable batteries.

When the relay was adjusted so that the power received by the receiving aerial, without any addition, was just insufficient to operate it, the approach of a human body would cause sufficient increase in the received energy to "throw" the relay and thus operate the burglar-alarm bell. The additional energy resulting from reflection by the human body (Fig. 3) caused an increased current in the receiving aerial which was sufficient to operate the relay.

A simple 3-meter oscillator apparatus is shown in Fig. A. The oscillator inductance consists of 4 or 5 spaced turns of 2-inch diameter; midget variable condensers are used for blocking purposes. The base of the tube has been removed; about 300 volts on the plate will give good results. The circuit of the oscillator is shown in Fig. 4.

Many interesting tests can also be performed by using somewhat higher power. Fig. 5 shows an oscillator arrangement which can be used. The rods may consist of copper tubing (1/4-inch diameter); these should be spaced about 3 inches apart. The variable condenser (moved along the rods, as well as tuned, to change the wavelength) is a 13-plate, double-spaced receiving instrument of good design.

The "S-W Four" Receiving Set

(Continued from page 129)

path possible. The condensers are of such a design that a straight-line tuning effect is obtained. Special sockets are employed so as to minimize microphonic troubles. The complete list of part is: 1 S-W Four foundation unit, comprising 2 Alcoa shield cans, drilled; 3 bakelite sub-bases, drilled; brass posts for coil sockets, hardware, binding posts, pin plugs and jacks; 5 Aerovox fixed condensers, C3, C4, C5, C7, C9, .006-mf.; 1 Aerovox fixed condenser, C6, .0001-mf.; 1 Aerovox fixed condenser, C8, .002-mf.; R1, Yaxley fixed resistance, 5 ohms; R2, Yaxley fixed resistance, 10 ohms; R3, Aerovox grid leak, 3 megohms; R6, Carter fixed resistance, 2 ohms; R7, Aerovox grid resistor, 100,000 ohms.

Additional parts required: C1, C2, Cardwell taper-plate variable condensers, type 167-E, .00015-mf.; R5, Carter Hi-ohm variable resistance, 100,000 ohms; T1, T2, Amertran audio transformers, type AF-8; L1, L2, eight S-W Four plug-in coils (two for each waveband); V1, UX222 tube; V2, 112A tube; V3, 201A tube; V4, 112A or 171A tube; two National dials, type B; four Benjamin sockets; two De Jur 5-prong sockets (for coils); one Yaxley battery switch No. 10.

ORIGINAL LOFTIN WHITE TUNERS

Manufactured by **SONORA**

Radio & Phonograph Co. for their **\$895.00**

Comb. Phono. & Radio **DIMENSIONS OF TUNER:** 13"x6 1/2"x5 3/4"

WORKS EXCEPTIONALLY WELL WITH THE NEW LOFTIN - WHITE AMPLIFIER.

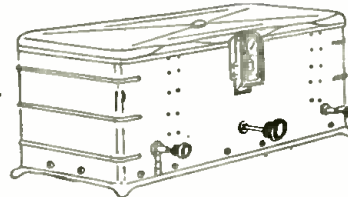

MODEL 226 FOR 3-226, 1-227

\$9.95

Model No. 227 **\$13.95** For 4-227 Tubes

Model No. 224 **\$16.95** 3-224, 1-227 Tubes

Model No. RA-1 **\$9.95** For 3 Arcturus 15-Volt, 1-227 Tube For D.C. or Battery

Model No. 201A **\$13.95** For 4-301A Tubes

Model No. 112A **\$13.95** For 4-112A Tubes

This tuner will work in conjunction with any amplifier such as THORDARSON-SAMSON-PILOT-AMERTRAN-NATIONAL-SILVER-MARSHALL using any type power tubes. We specialize in THORDARSON.

POWER AMPLIFIERS AND B SUPPLIES

250 Push-Pull	\$64.50	Single 250	\$34.50
210 Push-Pull	59.50	Single 210	29.50
245 Push-Pull	39.50	Single 245	24.50

LOFTIN-WHITE

DIRECT COUPLED AMPLIFIERS Licensed by the Inventors



MODEL **\$16.50** 245, wired

MODEL **\$29.50** 250, wired

A most remarkable and inexpensive amplifier for use in electrical reproduction of phonograph records and public address systems in halls, schools, churches and auditoriums.

SILVER-MARSHALL SHORT-WAVE



\$16.95

730 Round-the-World; four operated on batteries for best results. List price \$51.00.



TUBES

Types 224-227-245 280-226-171A-112A

Licensed by R. C. A. All types for your all-electric or battery set.

25c. ea.

GENUINE



50 % Discount on all Types

Type	List	Our Price
224	\$1.00	\$2.00
245	3.50	1.75
280	3.00	1.50
227	2.50	1.25
171	2.25	1.13
126	1.75	.88

All tubes tested and guaranteed by us and the manufacturer

MISCELLANEOUS SPECIALS THORDARSON

2 1/2 Volt, 12 Amp. Trans.	\$3.15
R171 and R210 Compact	4.89
250 Push-Pull Power Trans.	4.50
For 2-250, 2-281, 5-227 Tubes	
R245 Compact	10.80
250 Volt Pack with 280 Tube	9.95
S. M. 255, 256, 251	1.95
NATIONAL Velvet Dials	1.49
PEERLESS Klyelectron Speakers	3.95
WEBSTER 2A Pick-ups	8.75
SONORA-ACOUSTIC PRODS. Phono-Motor and Turn Table	8.95
WESTON 301-1, Ma. Meter	7.50
BALDWIN 110 A.C. Dynamic	9.95

RAWNER RADIO & TELEVISION CO.

MAIL ORDERS FILLED — NO SUBSTITUTION NO C. O. D.—INCLUDE POSTAGE IF SHIPMENT IS SMALL—OTHER SHIPMENTS BY EXPRESS.

DEPT. S.W., 142 LIBERTY ST., NEW YORK, N. Y. HITCHCOCK 4780-4781

DELFT

Something New!
MAKES PERFECT
SHORT-WAVE COILS

COIL WINDING KIT

Low Loss — Spacewound — Accurate!

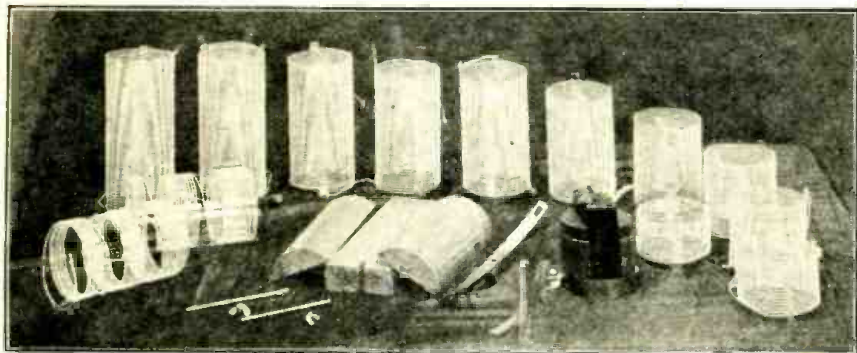

This new short-wave coil winder makes perfect coils in no time. The special threaded form gives exactly the same spacing between each of the coil's turns. It is 2 inches in diameter—the best size for all short-wave uses. When a coil is finished, the form collapses and slips out, leaving a perfect coil on a skeleton celluloid frame. There are no better coils than this. The kit comes complete with Delft form, discs, low-loss cement, plenty of wire, brushes, 50 ft. of cord, skeleton celluloid forms, and full instructions showing coil sizes for different wavelengths. Complete and ready to use—nothing else required. Why pay \$10 for a single set of coils when you can make all you want with this form? It never wears out. Send \$1.49 for the complete kit. Order now! You'll be surprised.

Another Delft Special: Short Wave Wavemeter for 15 to 100 meters, complete with coils and calibration charts, only \$5.00. Stop guessing at wavelengths.

DELFT RADIO, 524 Fairbanks Ave., Oakland, Calif.

BIG-PAY Positions in Radio and Television

Summer Is the Time To Prepare!
Get Ready for a Good Job Next Fall!

The relentless advance of this machine age is the stalking horror of the laboring man's existence—thousands of skilled mechanics displaced by marvelous machines. The best safeguard is to get into a field where the expansion is so rapid that the demand for skilled workers always far exceeds the supply. Radio with its increasing ramifications—television, "talkies", navigation, aviation, surgery, etc.—offers almost unlimited opportunities for steady work at good pay with fame and fortune within the possibilities of every diligent student.

Organized Labor—owner of Station WCFL, Chicago, the first station to broadcast television on a aural wavelength—seeks your good will and wants you to prosper. Labor suggests the study of Radio and Television as a happy and profitable means of getting better acquainted. As part of its national good-will campaign Station WCFL offers you a—

Complete Radio and Television Course ONLY

Handy Loose-Leaf Lesson Folder
Radio and Television Pocket Dictionary
Schematic and Template of Radio Receiver
WCFL Radio Magazine for One Whole Year

\$2

FOR ALL

You Assume No Moral Obligation in Partaking of Labor's Good-Will Project.

Supplied in any other way, this Radio and Television Course would cost you a lot of money. As a good-will project WCFL offers it to you for hardly more than the cost of postage and mailing. The WCFL Radio and Television Course is used as standard text in more than 400 High Schools, including some of the largest in the United States. It is also being studied by over 65,000 adults, and has helped thousands to increase their earnings and started them on

The Road To Big Pay In Permanent Positions

WCFL, 623 South Wabash Ave., Chicago, Ill.

For attached \$2.00, enroll me for WCFL Radio and Television Course. Also send me Loose-Leaf Lesson Binder, Radio and Television Dictionary, Schematic and Template of Radio Receiver, and WCFL Radio Magazine for One Year.

Name

Street

Post Office.....State

Fighting for the
Freedom of the Air

WCFL Radio Magazine is the only publication fighting for the maintenance of the freedom of the air—the gravest question now before the public. Whoever monopolizes broadcasting will dominate the Nation. The air MUST remain FREE!

Have You Subscribed to SHORT WAVE CRAFT yet?
To be sure of obtaining your copy—
don't fail to subscribe.

New Experiments in Ultra-Short Wave Operation

By DR. ERNEST BUSSE

(Continued from page 147)

and then determine by measurement that the volume has increased, say, 7.4 times. One has then the inward satisfaction of causing others to sit down and think over the results which are entirely different from those which they have obtained.

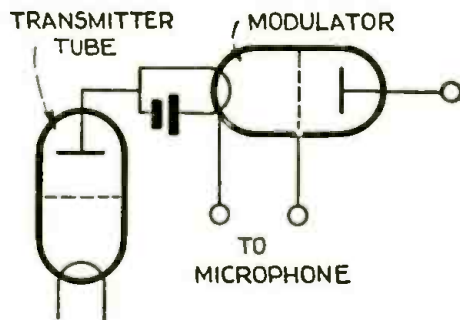

Fig. 2. Hook-up for ultra-short-wave transmitter and modulator tubes, with microphone connections.

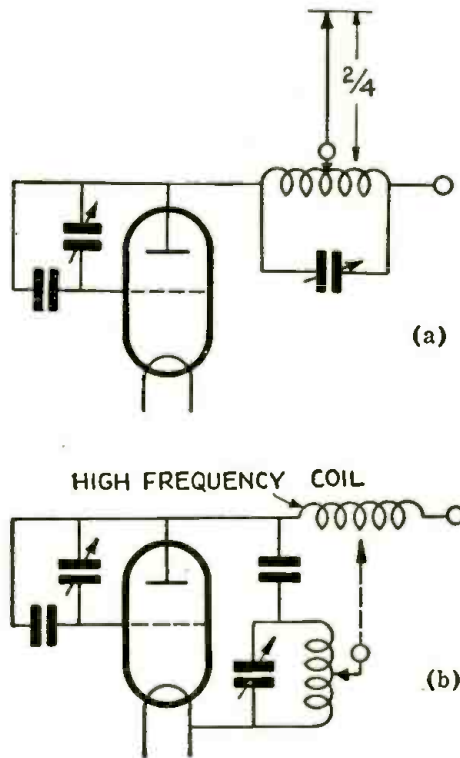

Fig. 3. Hook-ups for ultra-short-wave apparatus.

Characteristics of Ultra-Short Waves

In experimenting with waves between 3.0 and 4.5 meters, I have not yet learned of results which showed any considerable deflection in the path of the waves. The range is limited, approximately, by the horizon; though with very powerful transmitters and directional antennas, it is possible to go a little further. Exact figures are not yet available.

In large cities, the shielding effect of buildings is considerable, while in

smaller towns there are evidently fewer metal structures which can deflect the waves. In experiments, carried on at the suggestions and with the assistance of the police department of Salzburg, an entirely new series of results were obtained.

The wavelengths used were 3.8 and 7.2 meters; the latter was found to be

much more effective. Even in a deep, ravine-like valley district, behind a mountain mass miles thick, it was possible to receive where a connection by ordinary short waves could hardly be established at all. Also, within the city, the superiority of the longer waves was apparent. These phenomena are still under investigation.—*Funk Bastler.*

Aerials Used in Byrd Broadcast

By H. WINFIELD SECOR
(Continued from page 120)

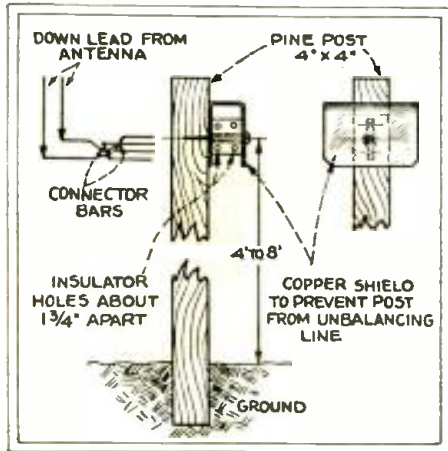

Fig. 4, above, shows the details of one of the numerous posts used to support the "transmission lines" connecting the short-wave receiving antennae with the receiving sets.

sired arrangement of resistance-, impedance-, or transformer-coupled stages. In one of the preferred forms in use at WGY, the first stage is resistance-coupled, the second impedance-coupled, and the third transformer-coupled. Any other arrangement desired, to obtain the results required for any special purpose, can of course be employed.

The received signal is then passed on through a line-amplifier of two stages, and is then sent over a telephone line to WGY's central station, eight miles away. A local monitor loud speaker is connected to the line amplifier; so that the operators at the Sacandaga receiv-

ing station know what is going on at any time.

Photographic Transmissions

When the writer visited the Sacandaga receiving station recently, he heard a short-wave facsimile signal coming in from Oakland, California, about 2,300 miles distant in an air line. The signal was a very healthy one, that is, strong, and of even amplitude. A 20-kw transmitter was sending the signal at Oakland. Among other things that the General Electric engineers experiment with are the transmission and reception of photos by means of revolving-cylinder machines, with well-known photoelectric recording attachments, etc.

The voice signals from the Byrd transmission were sufficiently clear to stand amplification to the point where they were recorded on a piece of film in the General Electric laboratories. The writer, at a later date, heard part of Admiral Byrd's conversation from Australia as it was reproduced from this piece of film through a vacuum-tube amplifier and a loud speaker, at a luncheon given at the Advertising Club in New York. This took place on the occasion of a talk on this very remarkable broadcast from Australia, by Martin P. Rice, manager of broadcasting for the General Electric Company.

A directive antenna was used for transmitting to Australia during the Byrd broadcast, the antenna being used in connection with the 20-kw short-wave transmitter of W2XAF. The direction of maximum activity from this antenna is at right angles to the antenna.

A Simple 5 Meter Transmitter

By E. T. SOMERSET, G2DT
(Continued from page 139)

It is advisable to place R. F. chokes in all leads, including "A+" and "A-." Keep grid and plate leads extremely short; and utilize very fine stranded wire, wound into a small spiral, for "A" leads to the detector tube, as a means of preventing wobulation.

The aerial may be 16 feet long, stretched tight, and clipped on to the grid coil at about 1/2-inch from the low-potential end. Alternatively, it may be loose-coupled by means of a single turn, 2 inches in diameter, and separated from the grid coil by 1 1/2 to 2 inches.

Circuit for a simple 5-meter receiver

is shown. It will be appreciated that no value, beyond that indicated in the text, can be given for the inductances: for these depend entirely upon the variable capacity used. The feed-back winding (tickler) should be half the diameter of the grid inductance and self-supporting from the regeneration condenser; about 4 turns of No. 18 will be suitable for a start. Extension shafts fitted to the variable condensers will be beneficial.

(The wire sizes quoted are British gauge, which are about two sizes larger than the American B & S gauge.)



Now available as a complete library—
Three books covering the entire field of building, repairing, and "trouble-shooting" on modern broadcast receiving sets.

993 pages
5 1/2 x 8 inches
fully illustrated

This Library serves alike the needs of the commercial radio dealer, installer and serviceman, and the amateur who keeps abreast with the latest trend in radio by building his own sets.

RADIO CONSTRUCTION LIBRARY

By JAMES A. MOYER
Director of University Extension, Massachusetts Department of Education
and JOHN F. WOSTREL
Instructor in Radio Division of University Extension, Massachusetts Department of Education

THESE three books embody not only a home-study course, but a ready means of reference for the experienced radio-trician. Step-by-step information is given on wiring, "trouble-shooting," installation and servicing to get the best tone quality, distance and selectivity in broadcast reception in all types of sets.

Practical data is given on radio equipment such as antenna systems, battery eliminators, loud speakers, chargers, vacuum tubes, etc., etc. Discusses modern short-wave receivers fully.

A section is devoted to the identification of common faults in receivers and methods of making workmanlike repairs.

The three books are profusely illustrated with understandable diagrams of hookups, connections, loud speaker units, installation work and antenna erection—as well as numerous photographs, tables and charts which clarify the text.

See this Library for 10 Days Free

No Money Down—Small Monthly Payments
It is your privilege to examine this Library for 10 days without cost. If it proves satisfactory, send an initial payment of only \$1.50 and \$2.00 a month until \$7.50 has been paid. Otherwise return the books.

**McGRAW-HILL
FREE EXAMINATION COUPON**

McGRAW-HILL BOOK COMPANY, Inc.
370 Seventh Avenue, New York.

You may send me the Radio Construction Library, three volumes, for 10 days' free examination. I agree to remit an initial payment of \$1.50 at the end of 10 days and \$2.00 a month until the price of \$7.50 has been paid—or—I will return the books.

Name

Home Address.....

City and State.....

Position

Name of Company..... SWC-8-30

SEND FOR THIS

Radio Bargain News

Dealers and Service Men
\$100,000
WORTH OF RADIO
MERCHANDISE SUCH AS REPLACEMENT
CONDENSER BLOCKS, TRANSFORMERS
SETS, SPEAKERS, AND TUBES SOLD
AT 75% OFF THE LIST PRICE.
SEND FOR FREE COPY OF THIS
BIG CATALOG JUST ISSUED

If you are not one of the 20,000 dealers on our mailing list, write in now.

Federated Purchaser
 16 HUDSON ST., NEW YORK CITY

My
 Short Wave Experiments
 in Carlsbad Cavern

By ERIC PALMER

(Continued from page 107)

and I used it when I was a member of the American-Brazilian Scientific Expedition in 1928. I had met the owner, Vasco Abreu, in New York.

Amateurs in France, England, Chile and other countries were heard on the 20-meter band, which is considered superior for daylight work.

Our party stopped at a camp some miles from the caverns. Everyone was anxious to hear programs at night, so I built a two-tube set. We were fortunate in hearing stations on both the Atlantic and Pacific coasts. The folks became so much interested in radio that they secured copies of my book, "Riding the Air Waves," from the publisher, Horace Liveright, in New York, and asked me for more details of the experiences mentioned there, relating to worldwide exchanges of gossip with other experimenters. WOAI and KMOG gave us dance music, which, even with only two tubes in the receiver, arrived with fine clarity and strength on an improvised loud speaker. This reception, which killed lonesomeness, was made possible by the extra batteries and tubes carried with our supplies. Around us was a desert and in the distance the Guadeloupe mountains. It was but a short auto run to the Mexican border—but with us were the entertainers of Los Angeles and New York!

And in the cave we heard merriment in London studios. Further, speaking of things British, I'm one up on Dad in the game we're playing, using radio in strange places. He claimed the distinction of being the first person to hear radio in Shakespeare's house, Stratford-on-Avon, but catching wireless waves in the Carlsbad Caverns is much more astonishing.

Short Wave Converters

By HENRY B. HERMAN

(Continued from page 131)

wave band from 15 to 200 meters with a .0005-mfd. tuning condenser. The range of the first coil is 15 to 80 meters; the second, 78 to 200 meters.

The oscillator plate winding, if it is to be an adjustable coil, consists of 10 turns of No. 18 enamelled wire on 2 3/4 inches diameter, 1 inch in length. Put on the winding at one extreme of this form, to allow room for a right-angle pivot bracket. Use two pieces of bakelite tubing, about 1 1/4 inch high, to pass 10 3/2 machine screws (about 3/8-inch outside diameter), as supports for the pivot and hence for the coil form itself.

The HY-7
 users say —

"California and England 20 meter zone are pie. Tuning the world without an antenna is new. Sydney, 2ME, like local." B. H. Taylor.

"Brought in stations I never heard before." Captain H. W. Atkins, S.S. Aryan.

"I've made and owned a lot of short-wave receivers, but nothing to compare with this." W1ACZ.

"You don't say enough about that receiver." W1HN.

"Only need 5 or 10 feet of wire for aerial." W1CMP.

"Some set!" W3PT. "Every other set I've had got no 20 meter signals."

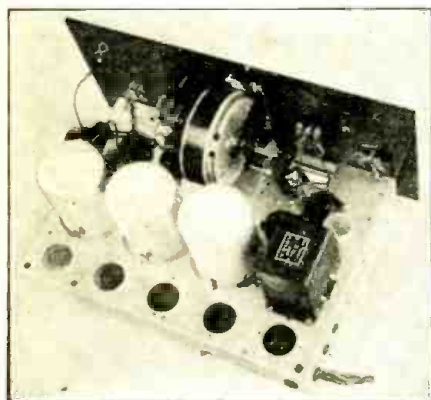

COMPLETE KIT
 Set Builders **\$58.50**
 Net Price

Comes assembled and ready to wire with all parts and full instructions.

All parts in stock. Also raw material such as wire, shielding, bakelite tubing, bakelite panels, knobs, etc. Questions answered by Mr. Hatry, the designer of the set. Write us if you have a special short-wave problem.

Hatry-Young

119
 Ann St.



Phone
 5-2733

HARTFORD, CONN., U. S. A.

TRADE DISCOUNTS

extended to

Set Builders

AMERTRAN TRANSFORMERS, FLECHTHEIM CONDENSERS, ELECTRAD RESISTORS, JENSEN SPEAKERS, MICROPHONES, WESTON METERS

Special

2 1/2, 5 or 7 1/2 Volt Transformers
 \$2.50 each

Radio Construction Laboratories

Specialists in Audio Amplifiers

142 LIBERTY ST. NEW YORK CITY

MICROPHONES

From \$10.00 to \$350.00

Also Stands, Transformers, Cable, Kits and Parts. Catalogue Just Out.

UNIVERSAL MICROPHONE CO., LTD.
 1163 Hyde Park Blvd., Inglewood, California
 Chicago, Cushing Co., 9 S. Clinton St.; Detroit,
 Spencer, 69 Seward; Omaha, Kohn, 304 Baum Bldg.;

Pittsburgh, Eitner Co., 405 Penn; Philadelphia, Engineering Sale, Bourse Bldg.; San Francisco, Hermans, 585 Mission; Oklahoma City, Southern Sales, 130 W. 3rd; Wichita Falls, Radio Supply Co.; Kansas City, Am. Radio, 1416 McGee; New York, Howard F. Smith, 112 Liberty; Boston, Ben's Tremont Supply, 228 Tremont; Export, Aurlima, 116 Broad St., N.Y.



The direction of winding is not important, except in the case of the plate coil. But the easiest solution is to disregard the direction of the winding even here, and to connect the coil in circuit; if oscillation fails, then reverse the connections of the terminals of the plate coil.

To receive the coils, special sockets are provided, which may be tip jacks, if home-constructed coils are used. Commercial panels have all sockets built in.

R. F. Choke Tests

The R. F. choke coils are shown mounted on the frames of the tuning condensers; this is accomplished by widening the hole on either side of the base strip of the R. F. choke (using either a drill or a penknife) to pass a 10/32 screw. As only one mounting hole is needed for each choke, two such screws are required. The tapped holes to receive these 10/32 screws, which should be no more than 1/2-inch long are in the condensers already.

Sometimes shielded R. F. chokes are so constructed that one terminal of the winding is connected to the shield inside. If this is true, no special precaution need be taken as to the choke used in the antenna-ground circuit, except to have the shield-connected terminal represent ground.

The test for this is to use a small dry-cell battery and a suitable indicating device; for instance, a 1.5-volt dry cell and a 0-6 voltmeter. Connect one terminal of the meter to one side of the battery, and have two free leads; one running from the other battery post; the other lead to the other side of the meter. To test for correct meter polarity, see that the deflection is positive; that is, gives the desired reading of 1.5 volts without regard to the coil. Connect one side of the battery to the frame of the shielded choke, the other free lead, from the meter, to one side of the coil. Then remove this connection from the coil and put it to the other terminal of the coil.

If the deflection is 1.5 volts from one side of the choke to the coil frame that side is the grounded one and should go to ground; the other choke lead going to antenna. Under these circumstances the other side of the choke, because of the resistance of the winding included in the tested circuit, will give only a small deflection, instead of full 1.5 volts.

It is well to test both chokes, one after the other, and put markers on the terminals. If both terminals show only a slight deflection, instead of full 1.5 volts, then the coil is not connected inside to the shield at either terminal; and it should be selected for use in the plate circuit of the modulator, as this carries a high direct potential. The object is to avoid shorting due to the coil shield being connected to the condenser frame, or ground, and again to "B+" through internal conduction. If both R. F. chokes are grounded, insulate that used in the modulator plate circuit.

(Continued on page 171)

There Are THRILLS APLENTY on the SHORT-WAVES

NEW and unexplored fields are open to the short-wave experimenter. Let Hammarlund help you get the most out of them.



Whether you build your receiver for short-wave broadcast or code reception, remember that quality of parts spells the difference between ordinary results and real thrills.

Your dealer can supply you with Hammarlund Short-Wave Condensers, Plug-in Coils for various wave-bands, Chokes, Equalizers, Audio Transformers and Shields. Experts say, "You can't buy better."

Write Dept. SC-8 for Folder Describing the Many New Hammarlund Products

HAMMARLUND MANUFACTURING CO.
424-438 W. 33rd St., NEW YORK, N. Y.

For Better Radio
Hammarlund
PRECISION
PRODUCTS

REPLACEMENT PARTS

for

**FREED - EISEMANN,
FRESHMAN, EARL
AND FREED SETS**

Toggle Switches as used in Radiola Receivers, Model 17-18, 44-46, etc.
\$.15 each, \$1.50 doz.

Toggle Switch as used in Freshman Q, Freed 55-56-78-79-95, \$1.14.

Volume controls on Freed-Eisemann Model 80-85, \$2.27.

Carbon Resistors, 1% accurate, 375-500-1,000-1,500-2,000-10,000-15,000-25,000-20,000-50,000-100,000-250,000—2 meg., \$1.00 doz.

(B) Eliminator Trans. for replacement on Freshman G pack and all eliminators using 280 rectifier tube, \$1.10.

Freed-Eisemann Single Jacks, \$0.05.

Replacement Condensers in cases, size 4 1/2 x 1 x 2 1/2 in.—

- 1 MF — 600 volt \$35
- 2 MF — 600 volt .45
- 4 MF — 600 volt .55

Mazda 2 1/2 volt Pilot Lamps, \$1.25 doz.

All American D.C. Chassis, \$16.50—7-tube receiver.

We will answer all questions relating to above sets.

Send for special service parts bulletin.

Freed Radio Sales Service

16 Hudson St., New York City, N. Y.

"The S-W-Four"

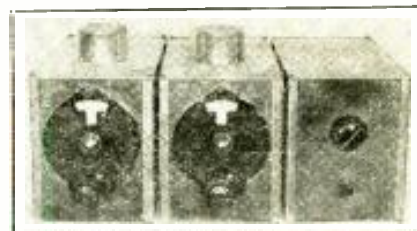

Have you read the article about the "S.W. 4" Short Wave Receiver in this issue? Then write for new prices. Available as a complete kit or we can supply the foundation unit only. The Radio-Frequency unit, consisting of the first two cans, will appeal to those who have their own power-packs or to television experimenters who want a good short wave receiver.

Authorized by Wireless Egert Engineering, Inc.

DEALERS WANTED

Address all communications to

EASTERN COIL CO.

56 Christopher Avenue
Brooklyn New York

What Type Audio Amplifier Have You Found Best For Short Wave Reception ?

Submit an article describing it to the Editor of this magazine. If we publish it, we will pay you for it.

A Short-Wave Converter

That Works on Any Broadcast Receiver

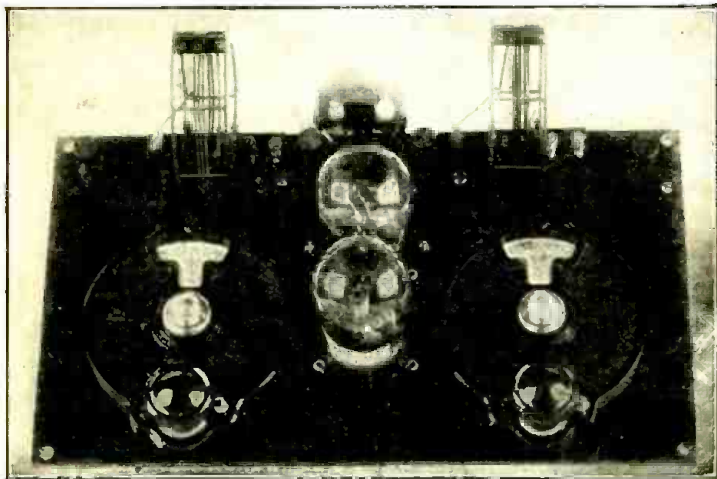

Doubles the Value of Your Present Broadcast Receiver

THE NEWLY perfected short-wave converter is called the Universal Converter because it is universally useful. It works on any broadcast receiver, including all tuned radio frequency receivers, screen grid or otherwise, Neutrodynes, Super-Heterodynes, and all or any other types. If a set brings in broadcast stations it will bring in short waves when this converter is used.

There are three ways of receiving short waves. (1)—You may use a receiver designed for short-wave reception exclusively. (2)—You may use an adapter, which is usually of a low order of sensitivity and can not be relied on to work on all receivers, or (3)—You may use a converter.

Suppose you have an AC or other high-powered receiver for broadcast reception. If you want a short-wave receiver of equal standing you will have to provide the same amount of radio frequency and audio frequency amplification. You will have to spend as much, again, as you did for your broadcast receiver. If you use a mere adapter you take your chances of results—you may get no results. But if you use a converter, like the Universal, you capitalize on your investment in your broadcast receiver, and now for the first time have a receiver that will do more on the short waves than it does on broadcast waves. Therefore you double the value of your present broadcast receiver.

HOW would you like to have a short-wave converter to connect to your present broadcast receiver, so as to use every stage of amplification in that broadcast receiver, applying that amplification to short waves? It CAN be done! It is really very simple. If you put the proper kind of short-wave tuner ahead of your entire broadcast receiver, connecting the output of the short-wave tuner to the input of the broadcast receiver, you will solve the riddle that has been engaging the attention of scientists for many years.

There is one best way of doing this, and you will want to learn the full details, and from the pen of the very man who worked out this system to such a high point of achievement.

Here is a glimpse of what is done to accomplish the result: A short-wave tuner is constructed, consisting of one untuned stage of radio frequency amplification, and two tuned stages. Three tubes are used in the short-wave tuner. The circuit then is wired to permit the output of the short-wave tuner to be received and amplified by your broadcast receiver. All the radio frequency amplification in your broadcast receiver is used to its fullest, also the broadcast receiver's detector, and all the audio-frequency amplification, in a word, your present receiver, as it is. Therefore the new device is a converter, in that it converts your entire broadcast receiver to short-wave reception and is not a short-wave adapter, as an adapter uses only the audio frequency amplification, and none of the radio frequency amplification, of the broadcast receiver.

NOW you may choose at any time to receive short waves, just as you have been able to choose at random the broadcast stations you desired to hear, with the exception that your distance-getting is rather restricted on broadcast wavelengths, whereas on short waves you may hear stations from anywhere on earth.

It is not at all uncommon in one evening to tune in three or four foreign stations, even more, when you use the Universal Converter, as well as receiving stations across the width of the Continent. The uncanny penetration of short waves is yours to enjoy to the utmost, and in a manner that uses all of your broadcast receiver—all tubes, all coils, all condensers, B supply, speaker, baffle, console—everything!

You take what you've got, and add a little to it by connecting two wires to the antenna and ground posts of your broadcast receiver, and one wire elsewhere, and a magic transformation has been made.

You don't need batteries for the converters.

You will want to read all about this efficient and compact converter—this fascinating circuit that, with few parts, turns the trick that has teased scientists for years. You will find the subject treated thoroughly in the May 3d, 10th, 17th and 24th issues of RADIO WORLD, the first and only national radio weekly, now in its ninth year.

Read All About This Marvelous Converter

RADIO WORLD publishes all the latest circuits and news of radio. Its technical presentations are highly authoritative. Construction of ultra-sensitive circuits and a wide range of superior power amplifiers is featured regularly. Have you heard of the Six-Circuit Tuner? If not, you'd better inform yourself at once of this remarkable circuit for broadcast reception, and by the way, a circuit that gives you the utmost radio frequency amplification, with band pass filter besides. It's discussed in the same four issues. Read RADIO WORLD and follow the development on short waves, the Loftin-White amplifiers, pentodes, band pass filters, pre-selectors, Super-Heterodynes, sidebands, screen grid tubes, and push-pull. Enjoy the lists of stations, published frequently both broadcast and short waves.

RADIO WORLD, published weekly, sells for 15c a copy and is purchasable at all news-stands. The regular subscription rates are \$1 for 8 weeks, \$1.50 for 13 weeks, \$3 for 26 weeks and \$6 a year. Remember, RADIO WORLD is published every week, so you get the news while it is news.

Send \$1 for an 8-weeks' trial subscription, beginning with the regular rate) and read up on this marvelous short-wave converter, in the May 3d, 10th, 17th and 24th issues and get absolutely free, a blueprint of the converter. Fill out and mail the attached coupon. Present subscribers for RADIO WORLD may extend their subscription by putting a cross in square in the coupon when remitting.

THOSE who know nothing or next to nothing about radio, or experts who want to make a present of a book to the veriest novice, will be interested in "Foothold on Radio," by J. E. Anderson and Herman Bernard. Nobody who reads this book need know a single thing about radio, yet when he finishes reading it he will have a good foothold on the subject. There have been many other books for novices, but all such books require some fundamental knowledge of radio or allied electrical knowledge. This book takes nothing for granted, and yet it presents the picture of radio in its technical side without resort to mathematics, and without requiring anything other than that the reader be able to read the English language.

"Foothold on Radio," published in May, 1930, is just the volume the merest novices, thirsting for some technical insight into the wonders of radio, have been awaiting.

"The Super-Heterodyne" is the title of another volume by Anderson and Bernard, to be published in June. The theory and practice of this receiver are thoroughly analyzed, and the theory has been incorporated in a practical circuit design, with full constructional details, all constants revealed.

You may obtain the short-wave converter blueprint, also "Foothold on Radio," also "The Super-Heterodyne" (all three), by sending \$6 for a year's subscription for RADIO WORLD (52 issues, one each week). Present subscribers may extend their subscriptions under this offer, too.

RADIO WORLD, 115 West 43rd Street, New York, N. Y.

Enclosed please find \$1.00 for which enter my name as a subscriber for RADIO WORLD for eight weeks, beginning with the May 3d issue, and send FREE a blueprint of the short-wave converter, with list of parts and constants.

Enclosed please find \$6 for which enter my name as a subscriber for RADIO WORLD for one year (52 weeks), beginning with the May 3d issue, and send me FREE the following premiums: blueprint of the short-wave converter, with list of parts and constants; one copy of "Foothold on Radio" and one copy of "The Super-Heterodyne."

NAME

ADDRESS

CITY..... STATE.....

If extending a present subscription for RADIO WORLD please put a cross in square at left.

Short Wave Converters

(Continued from page 169)

If both coil terminals, connected one after another in series with the test circuit to the coil shield, show full 1.5 volts, the entire choke is short circuited.

List of Parts for "Battery" Type Converter

Two sets of Screen Grid Coil Co., De Luxe short-wave coils, wound on air dielectric, two coils to a set;

Two .0005 mfd. Hammarlund de luxe straight-line frequency tuning condensers;

Two radio-frequency choke coils 50-millihenry, shielded type;

One .00035-mfd. fixed condenser;

One .00025-mfd. fixed grid condenser with clips;

One 5 to 7 meg. grid leak, with mounting;

Three 4-ohm filament resistors with mountings;

One .01-mfd. fixed condenser;

One 7 x 14-inch drilled bakelite panel, with three UX tube sockets. (4-spring) and coil sockets built in;

One cabinet to fit;

Five binding posts;

Two National Type B "Velvet" vernier dials, with two pilot lamps (use of pilots

optional; connect in series across 5 or 6 volts).

List of Parts for "A. C. Type" Converter

Two sets of Screen Grid Coil Co. "De Luxe" short-wave coils;

Two .0005 mfd. Hammarlund de luxe straight-line frequency tuning condensers;

Two radio-frequency choke coils, 50-mh. shielded type;

One .00035-mfd. fixed condenser;

One .00025-mfd. fixed grid condenser with clips;

One 5 to 7 meg. grid leak;

Two Electrad wire-wound, flexible type, biasing resistors, 300 ohms each;

Three .01-mfd. fixed condensers;

One 7 x 14-inch drilled bakelite panel, with three UY tube sockets (5-spring) and coil sockets built in;

One cabinet to fit;

Four binding posts;

One Polo 2.5-volt center-tapped filament transformer, 6-ampere rating;

Two National Type VB-D "Velvet" vernier dials, with 2.5-volt pilot lights and lamp brackets.

The Mercury Super-Ten S-W Receiver

(Continued from page 128)

highly efficient type of coupling, upon which depends the selectivity of the set when receiving ultra-short, short and standard wavelengths, is used between the primary and secondary of these coils.

The fourth photo shows a perspective view of the Mercury "Scout" model; this is 10 inches long by 5½ inches high by 7 inches deep, has removable inductances as will be noted, and also a powerful and sensitive intermediate-frequency amplifier with an adjustable shield. These two adjusting nuts can be seen on the top of the receiver; these, of course, have been sealed and no further adjustments are required.

The split oscillator condenser is shown on the right. In this model, ten peanut tubes are used, as in the standard type. Both sets have cable attachments for

battery use and can be used as an all-electric receiver by the application of a special rectifying unit for 60-, 50- or 25-cycle, 110-120-volt current. The manufacturers can supply this, but any 6-volt standard eliminator will do.

The Peanut Tubes Used in the Set

The R215A, or, as it is commonly called in Canada, the "peanut" tube, is known as the "N" tube in the United States, and has been used with great success in the U. S. Navy superheterodynes; as it is small, it is quite sturdy, and will stand rude shocks and jolts that would ruin or entirely smash a larger type tube. Its elements are very small and the internal capacities low.

(Unfortunately, no manufacturer has seen fit to make these tubes available on the open market in the United States.)

Radio Etiquette

(Continued from page 143)

It Ought to Teach John a Lesson

It is to be hoped that Mr. Adams will take this letter in the helpful spirit in which it was evidently written. When John goes to call on the governor of the city I hope he has his pants pressed and puts on a clean collar and everything. And, John, remember your dear old mother and your sisters, and then you will not forget to be "decent with little NRH." One ought to be decent with all little NRH's, John, so they will not be calling up some time in the future to remind you that you promised this and swore that.

And none will deny that Costa Rica speaks nothing but a simple law of etiquette when it reminds John that one does not carry on a polite conversation with post cards. That was one of the first things my grandmother taught me. She said one never should use the post card for other correspondence than to remind one's relatives that one was here and having a good time and wishing they were the same.

Looking at it by and large, I think this letter should be very helpful to John. It is well to receive such lessons while we are still young and in the formative stage.

Makes Your Radio BEHAVE!



ENJOY steady radioperformance with uniform volume undisturbed by the everchanging house electric supply.

The new AMPERITE for electric radio smooths out current fluctuations automatically. Requires no attention.

Insist on AMPERITE in the electric radio you buy or build. No radio can be modern without it.

FREE—Useful AMPERITE Bulletin and list of AMPERITE-equipped radios. Write Dept. SC-7.

AMPERITE Corporation
561 BROADWAY, NEW YORK

AMPERITE

Self-Adjusting
LINE VOLTAGE CONTROL

MORE BARGAINS!!

QUALITY MERCHANDISE AT LOWEST PRICES
MONEY RETURNED IF NOT SATISFIED

Only a few hundred more of the well-known PARSON 114k Voltage Transformers at these low prices! Every one brand new. Neat metal cases. Filter Condensers: (All ratings Continuous DC Working Voltages) 1000 Volt, 1 Mfd.—\$1.80, 2 Mfd.—\$2.50, 4 Mfd.—\$3.95, 8 Mfd.—\$7.95, 2000 Volt, 1 Mfd.—\$3.80, 2 Mfd.—\$5.90, RCA or Stromberg-Carlson Filter Condensers, Metal cases, Lug terminals 4 Mfd., 650 Volt DC Working—\$2.95, Four for \$7.75, 7 Mfd., 650 Volts—\$2.60, Four for \$9.60, 2 Mfd., 450 Volt—\$1.75, Six for \$1.20.

U. S. Tool, 11 Plate SLE Variable Condensers, One-hole mount, Low-loss.—\$1.00, Two for \$1.75.

FRESHMAN POWER TRANSFORMERS. A heavy, well-built transformer in compound filled case. Has a 275 volt winding and two 7½ volt center-tapped windings. 125 Watt, 7½ lbs. Complete power supply for 210 Amplifier, Transmitter, or Eliminator.—\$2.10. Two will give 750, 7 1/2, 7 1/2, 7 1/2, and 7 1/2 Volts. All center-tapped. SPECIAL: Two for \$3.95. THORNTON Power Transformers: Type T-3202, 250 Watts, 1200, 7 1/2, 7 1/2, and 3 Volts. All CT.—\$5.75, T-3321, 175 Watts, 1100, 7 1/2, 7 1/2, and 3 Volts. All CT.—\$1.50, T-2130-A, 150 Watts, 800 and 5 Volts. CT.—\$3.95.

VICTOR ABC POWER TRANSFORMER. Special—\$2.75. RCA 3:1 Audio transformers—\$1.15. Output transformers—\$1.20.

POWER CHOKES: 2½ Amp. "A." 6 lbs.—\$1.95, ½ Ohm, 2000 MA., 5 H. Key thump filter choke, 6½ lbs.—\$2.95. Thornton T-2458 Double Choke. Each 18 H. 250 MA.—\$6.25. RCA double filter chokes. Metal case containing two 30 H. 80 MA. chokes. RCA Part No. 8336, 1000 volt insulation. Connected in parallel total is 30 H. 160 MA., 6 lbs. SPECIAL.—\$2.50.

Victor 30 H. 125 MA Metal Cased Chokes—\$1.60. Guaranteed TUBES. Unconditional FREE 60 Day Replacement. A guarantee that really means something! UX-250—\$1.85, UX-210—\$3.95, UX-281—\$3.25, UX-222—\$3.25, UX-224—\$2.05, UX-245—\$1.75. Every tube tested before shipping. Good Tubes at lowest prices! (7 day replacement) UX-250—\$2.20, UX-210—\$2.10, UX-281—\$1.50. Other types in catalog.

RCA 5000 ohm, 50 watt Grid Leaks.—48c. Two for 89c.

2% discount for full remittance (plus postage) with order. 20c charge is made on orders under \$2.00. 20% Deposit Required.

"QUICK SERVICE"—SEND FOR CATALOG

HARRISON RADIO CO.

35 Ft. Washington Ave. Dept. C New York City

STUDY RADIO

UNDER THE MOST FAVORABLE CONDITIONS

INDIVIDUAL INSTRUCTION IN A MODERN RADIO LABORATORY

Practical Course of Study Includes

- R } THEORY
- A } MATHEMATICS
- D } DESIGNING
- I } DRAFTING
- O }

And Construction of All Types of D. C. and A. C. Receivers

DAY AND EVENING SESSIONS

Enroll Any Time

Coe Radio Institute

Dept. S.W.

78-80 Cortlandt St.

N. Y. City

The "SUN" Short-Wave Tuner

Many months of practical experimentation were spent in simplifying the SUN Short-Wave Tuner (designed by Jack Grand) so that now anyone interested in radio, even with the slightest knowledge of radio construction, can easily build this short-wave receiver in a few hours, at low cost.

All parts for the "Sun" Short-Wave Set in stock.

Complete parts, including panel, etc. \$11.95

Full size blueprint 31c

Come in and see JACK GRAND

SUN RADIO CO.
64 YESEY ST. N.Y.

SM

New Catalog Supplement!

Silver-Marshall, Inc., 6457 West 65th St., Chicago, U.S.A.

Please send me FREE, the new S-M Catalog Supplement.

2c enclosed, please send me Data Sheet No. 21 (Short-Wave Bearcat.)

Name

Address

The Problem of Building a Good S-W Receiver

By J. E. SMITH

(Continued from page 135)

frequency or, more likely, the double-detection or superheterodyne system, as we are more accustomed to call it. The writer, therefore, is directing your thoughts to this particular phase of short-wave reception for advance experimental work. Such short-wave superheterodyne receivers are particularly adaptable to telephony and television.

Superheterodyne Reception

A very simple diagram, showing a single control superheterodyne, is Fig. 3. The output circuit is from the filament of VT2 and the output. Observe that the secondary of the three-circuit arrangement is made to oscillate at a frequency differing from that of the incoming wave by a value corresponding to the frequency of the intermediate stage. If the "intermediate stage" is a broadcast receiver tuned to 1,000 kilocycles, the difference between the oscillator frequency and that of the incoming wave should be 1,000 kilocycles.

Note—Remove old tube and leads from base. Drill small holes for leads. Wind both coils same direction. Run ends of coils through prongs and solder.

SHORT WAVE RECEIVER USING TUBE BASE COILS AND MIDGET CONDENSERS

By P. H. QUINBY
9DXY, St. Louis, Mo.

REFERENCE TABLE

- C1—.0001-mf. mica fixed condenser.
- C2—.000015-mf. midget variable condenser, 7 plate.
- C3—.000015-mf. midget variable condenser, 7 plate.
- C4—.0005-mf. mica fixed condenser.
- C5—.0005-mf. mica fixed condenser.
- R1—10-megohm grid leak (noiseless).
- R2—0-50,000-ohm Bradleyohm.
- R3—Rheostat or Amperite.
- R4—1/10-megohm grid-leak.

- L1—Two turns bell wire around coil socket base.
- L2—Grid coil on plug in tube base.
- L3—Tickler on plug in tube base.

Wave Band	L2		L3	
	Turns	Wire Gauge	Turns	Wire Gauge
80	37	28	25	30
40	16	22	20	30
20	7	22	10	30
10	3	20	5	30
5	1	20	3	30

—Courtesy QST.

The Grebe Short Wave Receiver

(Continued from page 146)

setting will be necessary to maintain oscillation. If oscillations cease over a portion of the tuning range, and a great increase is required in the regeneration setting at these points, this is probably due to the natural period of the aerial, or one of its harmonics, falling in this tuning range. The coupling should be kept sufficiently loose to avoid this effect; or the period may be shifted by means of a series antenna condenser.

Locating Stations Quickly

To locate stations quickly, consult the tuning charts. Move the tuning dial across the position indicated with the set oscillating. When the beat-note whistle is located, reduce regeneration below the oscillation point. It must be remembered that a single division on the tuning

dial covers a wide frequency range, and the dial must be moved more slowly than in a broadcast receiver. A beat-frequency control is provided for the finest possible tuning.

For maximum sensitivity when receiving weak C. W. or I. C. W. code signals, or locating a phone station, the regeneration dial should be reduced to the lowest possible reading where oscillations are just maintained. Extremely loud C. W. signals will be received with greater intensity when the oscillations are stronger. When receiving phone signals, this dial should be just below the oscillating point.

The volume control operates on the audio amplifier, and is independent of tuning or regeneration.

Use of Aircraft Radiophone Speakers

(Continued from page 124)

shielded. When the larger planes are in operation, as many as 114 spark plugs may be firing. The effect of this interference would entirely ruin reception if shielding were disregarded.

An antenna, of course, must also be included. This may be of the mast type, approximately 6 feet high, with or without a doublet, or it may be a trailing wire. The tubes require filament current and plate voltage. This current may be provided either by a wind driven generator, a motor driven generator or a dynamotor operating from the plane's battery. The Boeing Air Lines installation is a typical one. Every Boeing plane to be produced in the future will be bonded, shielded and wired for radio. The first of the installations on their line ships, 18-passenger, tri-motored planes, will be

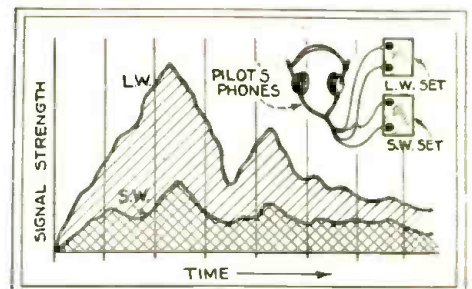

This chart shows how pilot listens to long and short wave signals simultaneously, strengthening the important one.

the long wave receiver, by which the voice is picked up from the ground station and the short wave receiver and transmitter, which makes two-way conversation possible.

◆ ◆ Official RADIO SERVICE MANUAL

and Complete Directory of all Commercial Wiring Diagrams of Receivers

PREPARED ESPECIALLY FOR THE RADIO SERVICE MAN !

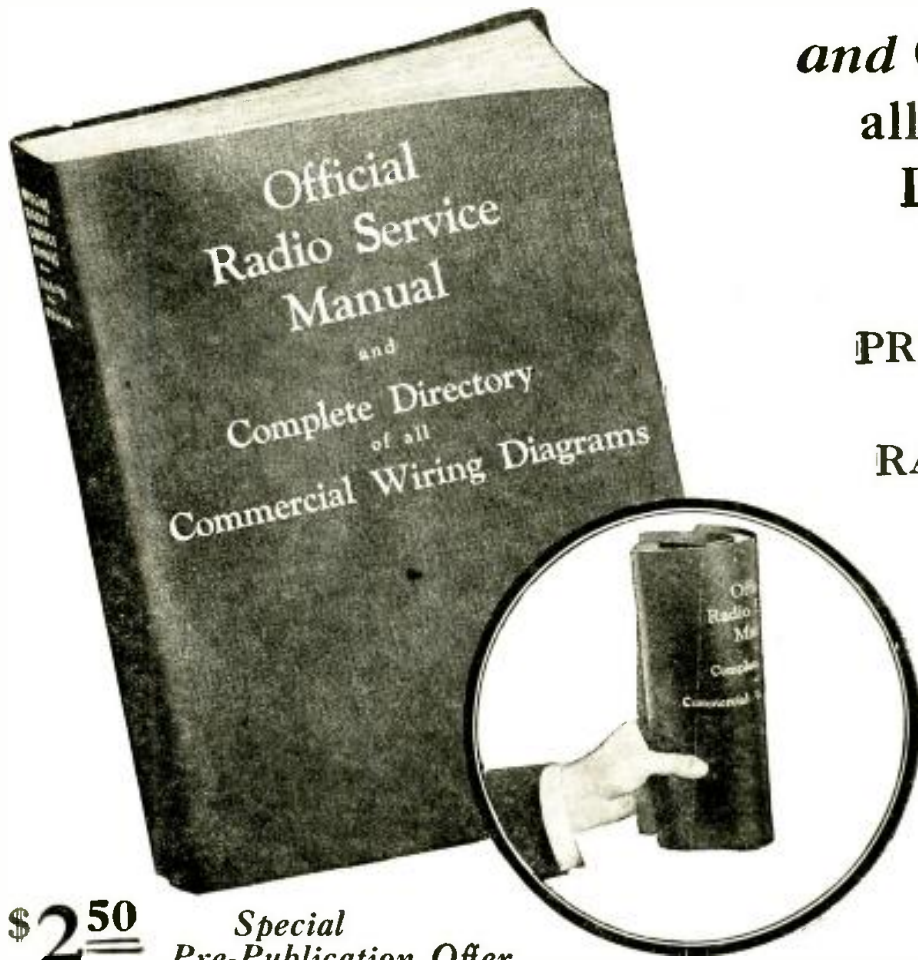

\$2⁵⁰ *Special Pre-Publication Offer*

HUGO GERNSBACK
Editor

CLYDE FITCH
Managing Editor

WE ANNOUNCE the early publication of the long-awaited OFFICIAL RADIO SERVICE MANUAL. This manual is the first complete and most up-to-date book of this kind. Nothing else like it has ever appeared in print.

A tremendous amount of material has been collected, not only for the Service Man, but for everyone interested in radio. A complete directory of every radio circuit of commercial receivers is now possible, and not only do you get every circuit of every set manufactured, of which there is any record, but in addition, an entirely new idea makes it possible to keep the manual up-to-date.

The OFFICIAL RADIO SERVICE MANUAL is made in loose-leaf form—handsomely made of flexible leatherette—the entire book can be folded and slipped easily into your pocket or put in your bag.

Rarely do manufacturers supply information about receivers made before 1927—even 1930 service data are not always available because many manufacturers do not supply independent Service Men with such data. And, when you can get the material from some of the manufacturers, it is of little use to you because it is not uniform, and it is scattered in different places; difficult to get at.

Additional service data, for new receivers as they appear on the market will be published and supplied at trifling cost so that the MANUAL may be kept up-to-date at all times.

SERVICE INFORMATION

But that is not all. The OFFICIAL RADIO SERVICE MANUAL contains also a most comprehensive instruction

course for radio Service Men, giving practical information from every angle on how to service sets.

In short, the OFFICIAL RADIO SERVICE MANUAL is the biggest thing of its kind that ever came along in radio. It will be hailed by every wide-awake radio man throughout the entire industry.

The size of the OFFICIAL RADIO SERVICE MANUAL is 9 in. by 12 in. There are several hundred pages, printed on good paper, and the book contains hundreds of illustrations and diagrams.

SPECIAL OFFER

The price will be \$3.50 upon publication of the book; but to our own subscribers and readers, we have a special pre-publication price of \$2.50, prepaid. This price will be withdrawn the minute the book is published, which will be during the next six weeks or sooner.

GERNSBACK PUBLICATIONS, INC.,
96-98 Park Place, New York, N. Y.

WC-8

As per your special offer, I enclose herewith \$2.50 for which you are to send me postpaid, one copy of the OFFICIAL RADIO SERVICE MANUAL as soon as it is published, at the pre-publication price of \$2.50. I understand that the price will be \$3.50 as soon as the MANUAL is published.

Name

Address

City..... State.....

RADIO BOOKS

for SHORT WAVE ENTHUSIASTS

WE HAVE made a special study of recent books for short wave fans and recommend the following excellent volumes. These books will be sent to you post-paid on receipt of the purchase price.

THE RADIO AMATEUR'S HANDBOOK, by A. Frederick Collins. 394 pages, 116 illustrations. One of the finest books on the market for the not-too-technical reader. Post-paid \$2.00.

RIDING THE AIR WAVES, by radio amateur, Eric Palmer, Jr. (W2ATZ). One of the best-known radio amateurs, who recently was called upon to help in exploring the Carlsbad (New Mexico) caves. A book that no radio amateur should overlook. 330 pages, profusely illustrated. Prepaid \$2.00.

DRAKE'S RADIO CYCLOPEDIA, by Manly. This is no doubt one of the finest volumes of this kind that has ever been published and it is something no radio man can do without. 1680 alphabetical headings, 1025 illustrations, 920 pages. 240 combinations for receiver layouts. Prepaid \$6.00.

FUNDAMENTALS OF RADIO, by Ramsey. An excellent text book that should be in the bookcase of every radio amateur. This book is a standard among all radio men. Contains 372 pages, 402 illustrations. Prepaid \$3.50.

TELEVISION TODAY AND TOMORROW, by Sydney A. Moseley (with a foreword by John L. Baird). Here is the latest book on television and one of the finest we have seen. Sooner or later, television is going to "break" and it may mean your future for you. This is THE great book, and gives you all the latest discoveries in this new art. The book has 130 pages and over 100 illustrations, hook ups, etc., many of which have never appeared anywhere before. This is a book you must have. Prepaid \$2.50.

RADIO PUBLICATIONS
98 Park Place, New York, N. Y.

SWAPPERS

- Want to swap correspondence? Send us your name and address on a post-card.—Editor.
- KENNYTH T. ADAMSON**
234 East 5th St., Plainfield, N. J.
- EDWARD ANDERSON**
9606 San Antonio Ave., South Gate, Calif.
- WILLIS E. BLANCHARD**
126 Grant St., Bangor, Me.
- DAVID BOROVIITZ**
1612 Summit Lake Blvd., Akron, O.
- JOSEPH BRIGHT**
826 East 221st St., New York, N. Y.
- M. W. DANIELS**
2300 Troost Ave., Kansas City, Mo.
- EMIL DARGES**
Amateur Radio Station W9GAS Ord. Nebr.
- DONALD GECK**
2205 Middlefield Rd., Cleveland Hghts., O.
- HAROLD F. GRAHAM, W3AUP**
630 Lincoln Ave., Pottstown, Pa.
- ROBERT GRANNAN**
108 Wood St., Loogootee, Ind.
- WILLIAM A. MCAULEY**
397 Highland Ave., Winchester, Mass.
- AUGUST MURPHY**
Mt. Loretto, S. I., N. Y.
- MARVIN L. NIELSEN**
Edna, Iowa
- LEO OHMAN**
1038 Blackstone, Fresno, Calif.
- O. INGMAR OLESON**
Drawer "D", Ambrose, N. Dak.
- FREDERICK J. PORTER**
16 Wesley St., Somerville, Mass.
- JAMES W. SHUNICK**
R. R. No. 2, Monmouth, Ill.
- HAYES STEINHAUSER**
11 Terrace St., Norwich, N. Y.
- C. J. STEPHENS**
P. O. Box 154, Tamaqua, Pa.
- GEO. W. THOMAS**
6461 Widman Pl., Detroit, Mich.
- MILLARD F. TIMM, W9EEQ**
706 East 10th St., North Platte, Nebr.
- HERMAN L. WAHL, JR.**
716 First Ave. E., Moberidge, S. Dak.

- MR. LEO WECOFSKY**
2836 West 35th St., Coney Island, N. Y.
- RICHARD P. TOMPKINS**
Westport, Conn.
- THEODORE VACHOVETZ**
Box 163, Elmsford, N. Y.
- DAVID VISE,**
2490 Buena Vista W., Detroit, Mich.
- M. VON PLOENNIES, W9BWC**
3851 Lincoln Ave., Chicago, Ill.
- WAYNE W. WHITMORE**
Harmon, Ill.

Cathode Ray Records High Frequency Oscillations

(Continued from page 121)

the diagrams herewith. As the electric currents supplying these deflecting electrodes fluctuate in accordance with the changes in the circuits to which they are connected, and which are under measurement, the cathode ray faithfully moves up and down and in various other directions, so as to give a curve or pattern, such as the regular oscillograms with which we are familiar.

One of the diagrams herewith shows the newest method of accomplishing this result by means of a Lenard window, which is mounted in the end of the cathode ray oscillograph tube. The cathode ray impinges in free air directly from the high vacuum, on the whole recording area of the photographic layer. The electron window (Lenard window) is supported against the air pressure by means of a grid. The Lenard window is made of very thin aluminum or cellophane foil, supported by a grid.

Short-Wave Stations of the World

(Continued from page 144)

Kilo-Meters cycles	Station	Time	Kilo-Meters cycles	Station	Time
49.97	6,000—ZL3ZC, Christchurch, New Zealand.	11 p.m.-midnight.	105.3	to 109.1 meters—2,750 to 2,850 kc. Television.	
	—EAR25, Barcelona, Spain.	Sat. 3 to 4 p.m.		—W2XBA, Newark, N. J., Tues. and Fri.	
	—RFN, Moscow, Russia.	Tues., Thurs., Sat. 8 to 9 a.m.		12 to 1 a.m.—W2XCL, Brooklyn, N. Y.	
	—Eiffel Tower, Paris, France	Testing 6:30 to 6:45 a.m., 1:15 to 1:30, 5:15 to 5:45 p.m., around this wave.		—W3XAU, Pittsburgh, Pa.—W1XB, Somerville, Mass.—W7XAO, Portland, Ore.—W9XAP, Chicago, Ill.—W2XAP, Jersey City, N. J.	
51.40	5,833—HK7, Barranquilla, Colombia.	8:30 to 10:30 p.m. exc. Sun.		—W2XCR, Jersey City, N. J. 8:15 and 9 p.m.	
52.00	5,770—AFL, Bergedorf, Germany.			—W2XBO, Long Island City, N. Y.	
52.72-54.44	5,690-5,510—Aircraft.		109.1	to 113.1 meters—2,650 to 2,750 kc. Television—W9XR, Chicago, Ill.	
51.02	5,550—WBXJ, Columbus, Ohio.		110.2	2,722—Aircraft.	
54.51	5,500—W2XBH, Brooklyn, New York City (WBBC, WGGU).		113.5	2,645—W2XBO, New York Central R.R. train.	
56.70	5,300—AGJ, Nauen, Germany. Occasionally after 7 p.m.		124.2	2,416—W2P, Seattle, Wash., Police and Fire Dept.	
58.00	5,170—OKIMPT, Prague, Czechoslovakia.	1 to 3:30 p.m., Tues. and Fri.	125.1	2,398—W9XL, Chicago, Ill.—W2XCU, Ampere, N. J.—And other experimental stations.	
60.90	4,920—LL, Paris, France.		128.0-129.0	—Aircraft.	
61.22	to 62.50 meters—4,800 to 4,900 kc. Television.		129.0	2,325—W10XZ, Airplane Television.	
	—WBXK, Pittsburgh, Pa.—W1XAY, Lexington, Mass.—W2XBU, Beacon, N. Y.; —WENR, Chicago, Ill.		135.0	2,220—Stockholm, Sweden.	
62.56	4,795—W3XAM, Elgin, Ill.—And other experimental stations.		131.3	2,285—W2XBO, N. Y. C. R. R. (Exp.)	
62.69	4,785—Aircraft.		136.4	to 142.0 meters—2,100 to 2,200 kc. Television.	
65.22	to 66.67 meters—4,500 to 4,600 kc. Television.			—W3XAU, Pittsburgh, Pa.—W1XB, Somerville, Mass.—W2XCW, Schenectady, N. Y.—W1XAV, Boston, Mass., 6 p.m.—W3XAV, Pittsburgh, 60 holes, 1200 rpm. 1:30-2:30 p.m., Mon., Wed., Fri. Westinghouse Electric & Mfg. Co.	
67.65	4,430—DOA, Doehertz, Germany.	6 to 7 p.m. 2 to 3 p.m., Mon., Wed., Fri.	142.9	to 150 meters—2,000 to 2,100 kc. Television.	
70.00	4,280—DHK2, Vienna, Austria. Sun., first 15 minutes of hour from 1 to 7 p.m.—RAS7, Khabarovsk, Siberia. 5-7:30 a.m.			—W2XCL, Brooklyn, N. Y. Mon., Wed., Fri. 9 to 10 p.m.—W9XAA, Chicago, Ill.—W2XBS, New York, N. Y., frame 60 lines deep, 72 wide, 1,200 R.P.M.—W1XAE, Springfield, Mass.—W3XAU, Pittsburgh, Pa.—W6XAM, Los Angeles.—W2XBU, Beacon, N. Y.—W3XAK, Bound Brook, N. J.—W3XK, Washington, D. C. Daily except Sun., 8 to 9 p.m.—W1XAU, Allwood, N. J.—W10XU, Airplane.—W2XBO, Long Island City, N. Y.	
71.77-72.98	4,180-4,100—Aircraft.		150	2,000—RA72, Smolensk, USSR.	
72.87	4,116—WOO, Deal, N. J.		149.9-174.8	—2,000-1,715—Amateur Telephony and Television.	
74.72	4,105—NAA, Arlington, Va. Time signals 8:55-9 a.m., 9:55-10 p.m.		175.2	1,712—WKDU, Cincinnati, Ohio. (Police Dept.)	
80.00	3,750—F8KR, Constantine, Tunis, Africa. Mon. and Fri.—13RD, Rome, Italy. (Testing)			—WMP, Framingham, Mass. 11 a.m., 1 and 5 p.m. daily. Music and police reports.—WRBH, Cleveland, O. (Police Dept.)—KGIX—Pasadena, Calif. (Police Dept.)—St. Quentin, France.—FBFY, Cannes, France. 5 p.m. Wed.; 4 a.m. Sunday.	
82.90	3,620—DOA, Iloberitz, Germany.		178.1	1,684—W0KX, New York, N. Y. (Police Dept.)	
84.24	3,560—O27RL, Copenhagen, Denmark. Tuesday and Fri. after 6 p.m.—Amateur Telephony.		186.6	1,608—W9XAL, Chicago, Ill. (WMAC) and Aircraft Television.	
84.40-85.66	3,550-3,500—Amateur Telephony.			—W2XY, Newark, N. J.	
86.50-86.00	3,490-3,460—Aircraft.		187.0	1,604—W2XCU, Wired Radio, Ampere, N. J.—W2XCD, DeForest Radio Co., Passaic, N. J. 8-10 p.m.—And other experimental stations.	
92.50	3,250—W9XL, Chicago, Ill.—And other experimental stations.		196	1,530—Karlskrona, Sweden.	
91.76	3,166—W0CK, Detroit, Mich. (Police Dept.)		187.9	1,596—WKDT, Detroit, Mich. (Fire Dept.)	
93.48-97.71	3,112-3,070—Aircraft.			(Standard Television scanning, 48 lines, 900 R.P.M.)	
96.03	3,124—WOO, Deal, N. J.				
97.15	3,088—W10XZ, Airplane Television.				
97.53	3,076—W9XL, Chicago, Ill.				
98.95	3,030—Motala, Sweden. 11:30 a.m.-noon, 4-10 p.m.				
101.7	to 105.3 meters—2,850 to 2,950 kc. Television.				
	—W3XK, Silver Springs, Md. 8 to 9 p.m. except Sunday; WPY, Allwood, N. J.—W2XR, New York, N. Y.—W3XL, Bound Brook, N. J.				
101.4	2,870—6WF, Perth, Australia.—Milan, Italy. After 2 p.m.				



AMATEUR aviation constructors and aviation students—comprehensive chapters on construction of a monoplane and biplane with detailed practical hints on motors, instruments, gliders and other parts are found in this invaluable book. Replete with over 200 photographs, illustrations and working diagrams—also complete descriptions and photographs of latest types of planes.

50¢ The **On All Large** Copy **Newsstands**

Large Size (9 by 12 inches)—4 Color Cover—100 Large Pages

If your newsdealer cannot supply you with a copy of AVIATION MECHANICS, send fifty cents in U. S. stamps, check or money order to

POPULAR BOOK CORP.
93H Park Place, New York City

BARGAINS *unheard of before!*

DEALERS — RADIO SERVICE MEN: Astounding prices such as presented on this page for merchandise are rarely found anywhere. Advantage of these wonderful buys should be taken NOW. Even stocking them will save you considerable money.

Readrite 245 Tester and Carrying Case

For A.C.-D.C.
and Screen
Grid Tubes

**Our Price
\$9.95**

Tests Screen Grid
Tubes

This tester is especially designed for the new sets with 224 and 245 tubes. It is equipped

with three double reading instruments: a milliammeter 0-20-100, a D.C. voltmeter 0-60-300, and a repulsion type A.C.-D.C. voltmeter 0-10-140. This latter instrument should not be confused with the vane type, with its restricted application. A grid bias switch is provided. Extra cords and tip jack connections permit the use of each meter individually. Also checks line voltage. Very compact and complete.

The extra cords are carried in the metal cover, which has a leather handle. Size 4 x 8 1/2 x 3 1/4 in. high. Cover finished in baked black enamel, wrinkle finish.



List \$20.00

BBL GIANT ELECTRIC MOTOR SPEAKER

Built on a
New Principle

Equipped with
Variable Impedance
Switch!

The B-B-L. Electric Motor is not just another semi-dynamic — it is built on an entirely new principle and is superior to any magnetic speaker on the market. Wonderfully sensitive (twice that of ordinary magnetics) which means that signals now received weakly are brought in with almost uncanny volume. Tremendous power from the Electric Motor enables you to use great volume without distortion of ordinary magnetics. No moving coil, no transformer, no rectifier, no condenser, no hum—just perfect satisfaction. Chassis only—9-inch diaphragm—12-inch frame

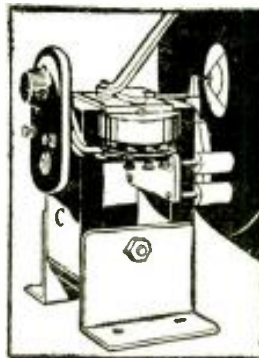

List \$22.50

Our Net Price \$6.95

READRITE No. 15 A.C.—D.C.

Set Analyzer
and Service Kit
and Tube
Tester

**Our Price
\$17.95**

An ideal servicing
outfit for either
A.C. or D.C. sets.
Embodies new and
valuable features.



List \$33.00

Equipped with regular adapters, and also a new adapter for testing screen grid tubes and a special switch adapter for full wave rectifying tubes. Adapter for Kellogg tubes may be had for one dollar extra.

Carries a triple reading D.C. voltmeter, a double reading A.C.-D.C. repulsion type voltmeter, and a double reading D.C. milliammeter. Instrument ranges. D.C. volts 0-60, 0-300, and 0-600; A.C. volts 0-10 and 0-140; milliamperes 0-20 and 0-100. Special tip jack connections permit individual use of these meters for a wide variety of testing, including continuity tests of transformers, chokes, condensers, etc.

Compartments for grid leaks, condensers, screws and findings. Space in bottom of case for soldering iron, tools and extra tubes. Size closed 7 x 7 1/4 x 14 in. Metal case finished in dark brown enamel.

\$3.75

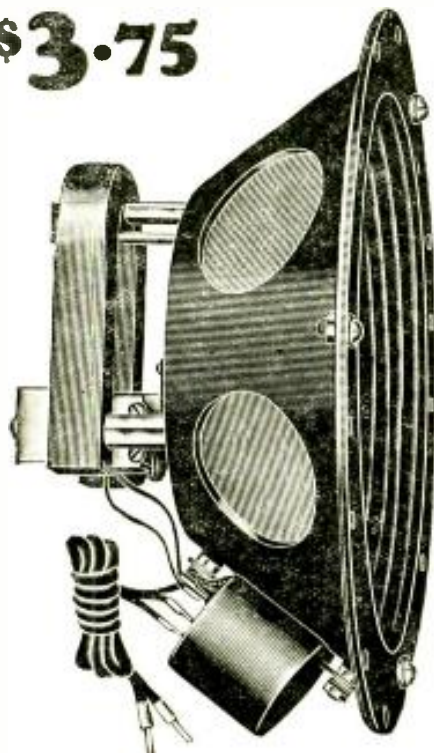

R C A MAGNETIC CHASSIS

What better recommendation can be made of this LATEST MODEL SPEAKER CHASSIS THAN TO MENTION THAT TWO OF THE GREATEST ORGANIZATIONS IN THE RADIO INDUSTRY, GENERAL ELECTRIC COMPANY AND RADIO CORPORATION OF AMERICA, ARE SPONSORS OF THIS PRODUCT! Before any item enters into the General Electric Co. production department, it must first pass through their WORLD RENOWNED LABORATORIES; no wonder then, that this speaker is conceded to be the WORLD'S BEST: This chassis is the identical one used in the R C A Model 100-A and 100-B Speakers, WHICH LIST FOR AS HIGH AS \$35.00.

Note built-in OUTPUT TRANSFORMER—this enables the speaker to be used with voltages applied to it as high as 600 volts, without any trace of distortion, rattling or blasting. Equipped with GENEROUS OVER-SIZED MAGNETS. The thick armature is ACCURATELY CENTERED. The STURDY METAL FRAME IS LINED WITH A SPECIAL FABRIC, greatly improving the acoustic properties of this sensational speaker! NOTE THE CORRUGATED SURFACE OF THE CONE, AN EXCLUSIVE FEATURE—ENHANCES PERFECT TONAL REPRODUCTION QUALITIES CONSIDERABLY. MOST COMPACTLY MADE: 9" OUTSIDE DIAMETERS, 4 1/2" deep-over-all.

IDEAL FOR AUTOMOBILE RADIO SPEAKER INSTALLATIONS—CAN BE MOUNTED IN ANY RADIO CONSOLE, or against any baffle arrangement. Complete with durable 5 foot cord.

SPEAKER CHAMBER FOR ABOVE CHASSIS

This speaker can be installed in this special ACOUSTICALLY PERFECT BAFFLE CHAMBER in a few moments. Front celotex baffle board included... \$0.85

If C.O.D. shipment is desired at least 20% remittance must accompany order—balance on delivery. If cash accompanies order for full amount deduct 2% discount. Include sufficient remittance if parcel post shipment is desired—any excess will be refunded.

Radio Surplus Corp.
56C VESEY ST. . . NEW YORK, N. Y.

FREE CATALOG!
Dealers are requested to send for our latest bulletin showing real bargains in excellent radio merchandise.

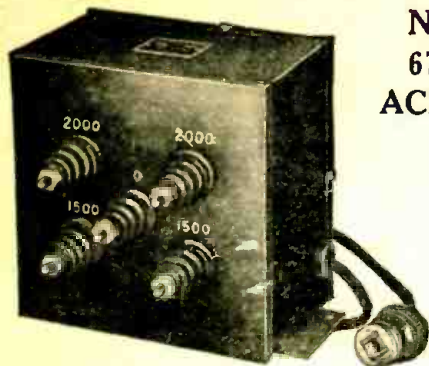

No. 672
ACME

We are sole United States agents for ACME plate and filament transformers and chokes.

Write at once for bulletin No. 110 and prices for special transformers.

The transformer illustrated here is No. 672, 500 V.A. Secondary Volts 2000-0-2000 (1500-0-1500). Secondary Amperes .125. Insulation 7000. Price \$21.00.

THORDARSON-R 210 POWER COMPACT TRANSFORMER

Supplies 400 Volts to the plate and 7½ Volts to filament on a UX 210 tube; also the filament current for the UX 216 B. Contains 2 choke coils of 80 M.A. current capacity for the filter circuit.

Special \$6.95

LEEDS

The Home of RADIO

45A VESEY STREET
NEW YORK

New York's Headquarters for
Transmitting Apparatus
When in Town Visit Our Store

Everything in
ACME JEWELL PYREX
BRADLEY FLERON
THORDARSON
ELECTRAD NATIONAL
LYNCH SIGNAL
FLECHTHEIM
NATIONAL RECTOBULB
GENERAL RADIO
CARDWELL
SAMSON EVEREADY
KINO AND TELEVISION CELLS
In Stock

NEON Glow Lamps



For wave meter and other uses; candelabra base, ½ watt. ¾ inch long over all. \$1.75

Special
Aluminum Shield cans and panels of every description to order.

Every Radio enthusiast, whether ham or professional, should know LEEDS RADIO. For almost 10 years, we have supplied the needs of our radio customers all over the world. Constant satisfaction—only the most reliable merchandise—lowest possible prices are some of the reasons why "LEEDS ALWAYS LEADS"



Leeds Microphone STANDS

Beautiful copper oxidized finish. Very sturdy construction. Artistically designed, effective appearance.

Desk Type, \$4.75
Price
Floor Type, \$9.75
Price
Adjustable to 7 feet

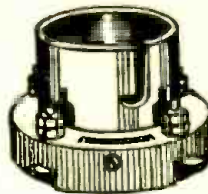

By Insistent Demand

LEEDS 50-watt socket, positive contact; heavy phosphor bronze springs, heavy brass shell; highest grade porcelain insulated base; will hold your tube in one position. Specially priced.

LEEDS RADIO LABORATORIES

Precision Custom Built Short Wave Receivers and Transmitters

This department under the supervision of the Short Wave Specialist Jerome Gross. We design, construct and advise on any material for the "Ham" Broadcasting station or laboratory. Write Jerry Gross for advice on any of your problems.

The LEEDS 1930 SPECIAL

A short wave receiver that's got them all beat. Best circuit design and finest mechanical construction. Praised by "Hams" everywhere as the greatest short wave receiver ever made. What some prominent users say—



"More than delighted with its performance." 4PD. "Far exceeded expectations." 2AFS. "Oscillation and tuning control far best I have ever seen." "Signal strength amazingly loud and response very clear."

In use by a constant host of Hams from coast to coast. 3-tube Receiver—detector—2 audio, using three 201-A tubes. Universal type, continuous range 15 to 100 meters; amateur type covers Ham bands 20-40-80 meters with generous spread on the dial.

Special Offer, Net \$37.50
3 Coils as illustrated \$6.50

TYPE 558 AMATEUR BAND



WAVEMETER

Type 558 Amateur-Band Wavemeter, a fixed air condenser is connected in parallel with the variable condenser. This arrangement spreads a narrow band of frequencies over the entire wave-meter scale which greatly increases the accuracy of reading. Five coils are used, covering the following amateur bands:

Coil A	4.6 to 5.4 Meters
C-II B	9.4 to 10.9 Meters
Coil C	18.5 to 21.5 Meters
Coil D	37.0 to 43.0 Meters
Coil E	75.0 to 86.0 Meters

The accuracy of calibration is to within 0.25%.
Type 558 Amateur-Band Wavemeter \$18.00

Make your own transmitting and receiving coils. Copper tubing transmitting inductance.

Inside Dia.	Size of tubing		
2 1/8"	9c	10c	12c*
2 3/8"	9c	10c	15c*
3 1/8"	10c	12c	17c*

Prices per turn

TYPE R-3 RECTOBULB

Still supreme—a 3000 Volt 250 mil Transmitting rectifier. \$10.00

TYPE R-81
can be used in place of any type 281 rectifier tube, with far better results. 7.5 v. fil. 750 v. plate. Fil. current 1.25 plate mills 150. Only 10 volts drop in tube. \$7.00

Leeds Listening MONITOR



For checking your note, its stability and whether D.C. or not. THE ONLY SURE CHECK. Gives you an accurate idea as to what your signal sounds like to the other fellow. The Leeds Monitor is encased in an aluminum shield 5"x6"x9" overall. Completely shielded, with batteries self contained. Supplied with A. & B. batteries, but without 1-UX 199 tube. \$15.00
Special

GENERAL RADIO TRANSMITTING CONDENSER

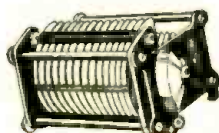

Type 334R—.00025 capacity. 3000 volts. \$5.50
331-T. .0001 \$2.75
334-V. .00005 2.50

New LEEDS The 1930 7 1/2-Watt 7 1/2-watt Hartley Transmitter, That Has Set the Country Talking



Extremely simple to adjust and operate. Will operate with a 201-A tube, with 90 volts on the plate, up to a UX-210, with 30 watts input; has plug in transmitting coils. List price

—kit \$55. Completely constructed \$70. \$57.50*
Special Offer, completely constructed....

Leeds Filament TRANSFORMERS

All primary windings for 115 volts, 50-60 cycles. Extra heavy construction, will stand considerable overload. Heavy aluminum end castings.

Type—L.F. 30—secondary 12 volts, centre tapped, capacity 30 watts.	\$5.50
Price	
L.F. 80—secondary 12 volts, centre tapped, capacity 80 watts.	\$6.50
Price	
L.F. 175—secondary 12 volts, centre tapped, capacity 175 watts.	\$9.75
Price	
L.F. 25—secondary 2 1/2 volts, capacity 10 amperes.	\$7.80
Price	

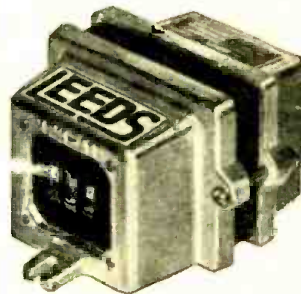

PLEASE PRINT YOUR NAME AND ADDRESS PLAINLY TO AVOID DELAY. WRITE FOR SPECIAL PRICE LIST.

Important! You may deduct 2% cash discount with any order taken from this page, provided you mention SHORT WAVE CRAFT.

MAIL ORDERS FILLED SAME DAY
10% Deposit Must Accompany All C. O. D. Orders

LET RCA INSTITUTES START YOU ON THE ROAD TO . . . SUCCESS IN RADIO

Radio needs you . . . That's why the entire Radio industry is calling for trained men . . . That's why thousands of men who answered these advertisements are now earning from \$2,000 and up a year. Radio is highly interesting work . . . with opportunities that are yet unlimited. Manufacturers and broadcasting stations are now eagerly seeking trained RCA Institute men . . . Aviation and radio in the movies also provide innumerable opportunities . . . Millions of sets need servicing . . . thousands of ships require experienced operators . . . Never before was there an opportunity like this in Radio.



Radio Mechanic and Inspector \$1800 to \$4,000 a Year.

This is the Only Course Sponsored by Radio Corporation of America

RCA sets the standards for practically the entire Radio Industry. . . The RCA Institutes' Home Laboratory Training Course enables you to learn more than the mere ABC's of Radio. . . In your spare time, in only an hour or so a day, you can obtain a thorough, practical education in Radio. . . You get the inside information, too, because you study right at the source of all the latest, up-to-the-minute developments. RCA, the world's largest Radio organization, sponsors every single detail in this course.

You learn Radio by actual experience with the remarkable outlay of apparatus given to every student. You learn the "How" as well as the "Why" of every Radio problem, such as repairing, installing and servicing fine sets. That's why every graduate of RCA Institutes has the experience, the ability and the confidence to hold a worthwhile Radio job.

Practical Instruction for You to Study in Your Own Home

RCA Institutes offers four different courses . . . certainly instruction that you need. A complete serviceman's and repairman's technical course . . . advanced course . . . complete course without code . . . and a complete course including code. And practical instruction with each course. Courses that teach construction, repairing, service, broadcasting and ship operating.

Graduates of RCA Institutes Find It Easier to Get Good Jobs

They are closest to the source of Radio's greatest achievements because so much of the progress of Radio is measured by the accomplishments of the great engineers in the huge research laboratories of the Radio Corporation of America.

Students of RCA Institutes get first-hand knowledge, get it quickly and get it complete. Success in radio depends upon training and that's the training you get with RCA Institutes. That's why every graduate who desired a position has been able to get one. . . That's why graduates are always in big demand.

Study Radio at the Oldest and Largest Commercial Training Organization in the World

Send for our Free Book . . . it will explain our practical methods of training that has prepared hundreds of men for success in Radio. Remember that you, too, can be successful . . . can speed up your earning capacity . . . can earn more money in Radio than you ever earned before. The man who trains today will hold down the worthwhile Radio job of the future. Come in and get our free book or send for it by mail. Everything you want to know about the opportunities in Radio. Forty fascinating pages, packed with pictures and descriptions of brilliant opportunities in this gigantic, world-wide profession.

See for yourself why graduates of RCA Institutes now occupy thousands of well-paid positions. These positions are usually available in from 3 to 10 days after graduation for men who can qualify. RCA Institutes will back you up to the limit. Our catalogue is yours free. . . SEND FOR IT TODAY!

Broadcast Station Mechanic \$1800 to \$3600 a Year.



Land Station Operator \$1800 to \$4000 a Year.

Broadcast Operators \$1800 to \$4800 a Year.



Clip this Coupon NOW!



RCA INSTITUTES, Inc.
Dept. S.W.C. 7, 75 Varick St., N. Y.

Gentlemen: Please send me your FREE 40-page book which illustrates the brilliant opportunities in Radio and describes your laboratory-method of instruction at home!

Name

Address

State

RCA INSTITUTES, INC.

A Division of the
Radio Corporation of America

SPONSORED BY



for . . . Dependability

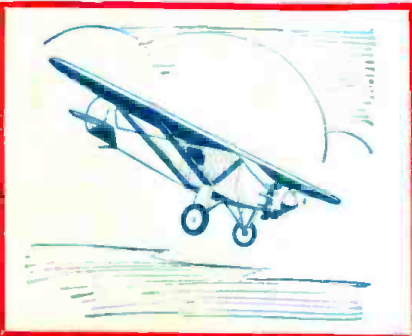

Up in the air—flying across great open stretches of sea to the little Isle of Bermuda, making a world record and keeping in touch with the world every minute of the day and night with a Pilot Super-Wasp Set, relying all the time on the Dependability of Pilotron Radio Tubes.



Camping miles from anywhere—enjoying some favorite program with your Auto-Pilot Screen Grid receiver and knowing that you can depend on your Pilotron Radio Tubes under all conditions.

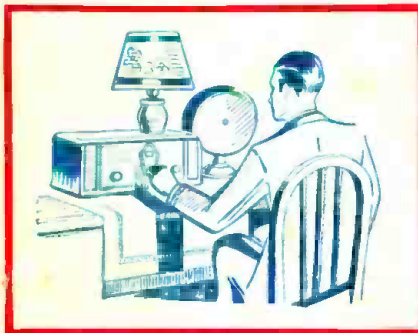

The Professional operating on world wide reception—keen and alert, must avoid confusing tube noises—crackles and distortion—and with dependable Pilotron Radio Tubes in every socket he enjoys the thrill of “pulling in” messages from far away.



You too—under all conditions—on any set will appreciate the difference that dependable Pilotron Radio “long life” Tubes give to the reception of radio broadcast programs.

PILOTRON

RADIO TUBES

ENDORSED BY PROFESSIONALS

LICENSED BY R C A

PILOT RADIO & TUBE CORP.

323 BERRY ST., BROOKLYN, NEW YORK
Chicago Office: 234 South Wells St.

FACTORIES AT LAWRENCE, MASS.
San Francisco Office: 1278 Mission St.